

This is a reproduction of a library book that was digitized by Google as part of an ongoing effort to preserve the information in books and make it universally accessible.

Google™ books

<https://books.google.com>

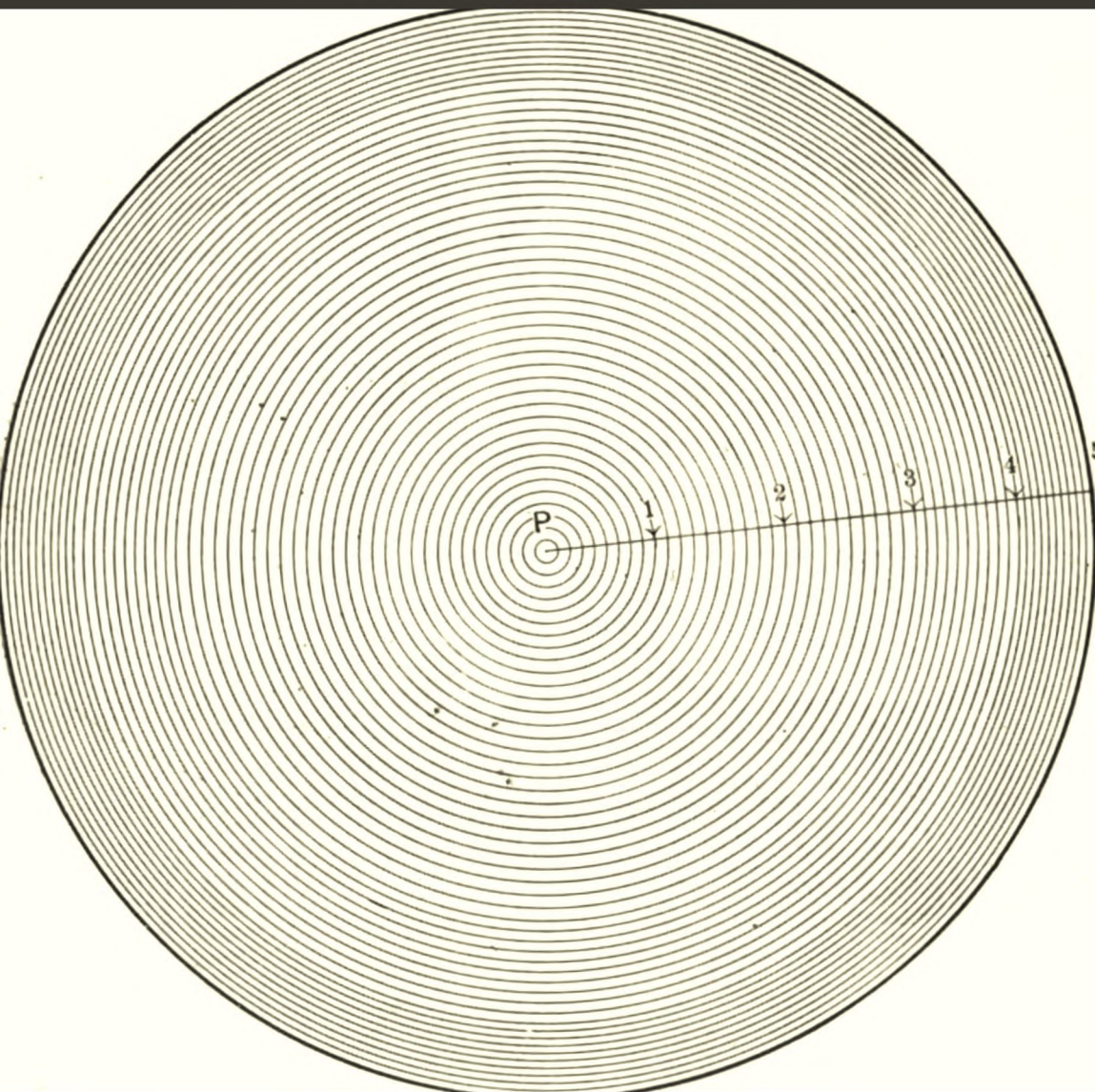



Forest Mensuration

Henry Solon Graves

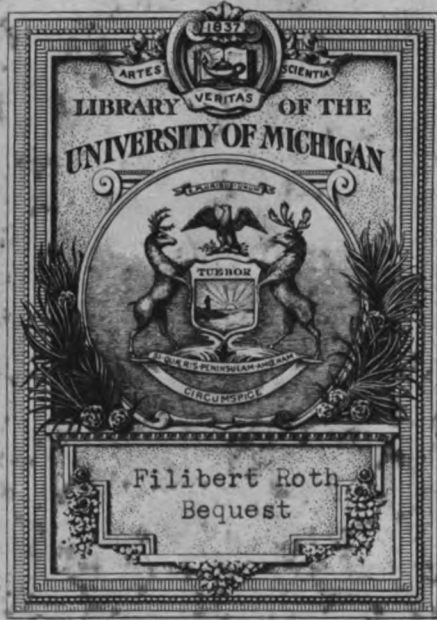

Forestry

SD

531

G78



HENRY SOLON GRAVES



FOREST MENSURATION

BY

HENRY SOLON GRAVES, M.A.

Director of the Forest School, Yale University

FIRST EDITION

FIRST THOUSAND



NEW YORK

JOHN WILEY & SONS

LONDON: CHAPMAN & HALL, LIMITED

1906

Copyright, 1906
BY
HENRY SOLON GRAVES

ROBERT DRUMMOND, PRINTER, NEW YORK

Sci. Lib.
Fidelent Rath Request
2-16-27

© 11-7-28 N. R. J.

TO MY FRIEND
George Dudley Seymour

PREFACE.

THE urgent need of a reference book in forest mensuration for class work at the Yale Forest School has induced me to publish my lectures, given during the past year, with such additions as are necessary to present the material in the form of a book.

This book is designed as a guide for students of forestry and as a reference book for practical foresters and lumbermen. It is not intended that it should replace the field instruction of the student of forest mensuration, for the subject cannot be mastered except through training and experience in the woods. Not only is it impossible to acquire from books the ability to estimate timber and to scale logs, but the scientific work in forest mensuration equally requires field experience. On the other hand, a systematic work describing the principles of forest measurements is of great service to a teacher in conducting his field instruction, and such a book should be of constant use to a forester, especially if he is engaged in research work. The material for the book has been selected with these principles in mind, and I have endeavored to furnish information which will be useful both to practical business men and to those engaged in work of investigation.

I have drawn freely from the experience of European foresters, with particular reference to their methods of measuring logs, determining the age of stands, and studying growth.

I have made special use of the works of Dr. Franz Baur and Dr. Udo Müller.

Acknowledgments are due to Mr. H. D. Tiemann for his assistance in preparing Chapters V and XVIII, to Mr. J. O. Hopwood for compiling the laws relating to the measurement of logs, and to Mr. Raphael Zon and Mr. Austin W. Hawes for reviewing certain portions of the work.

HENRY S. GRAVES.

YALE UNIVERSITY,
NEW HAVEN, CONN.,
August 1, 1906.

CONTENTS.

CHAPTER I.

INTRODUCTION.

SEC.	PAGE
1. Definition of Forest Mensuration.....	1
2. Importance of the Study of Forest Mensuration.....	2
3. Literature.....	7
4. Units of Measurement.....	8

CHAPTER II.

THE DETERMINATION OF THE CONTENTS OF LOGS IN BOARD MEASURE.

5. Definition of Board Measure.....	11
6. Board Measure Applied to Round Logs.....	12
7. Principles of Constructing Log Rules.....	12
8. Conditions Influencing the Contents of Logs in Board Feet....	13
9. Value of Board Measure Applied to Round Logs.....	14
10. Need of Uniformity in the Measurement of Logs.....	17
11. Principles of Constructing a Standard Log Rule.....	18
12. Selection of a Standard Rule.....	20
13. Construction of Local Log Rules.....	21
14. Graded Log Rules.....	21
15. Log Rules Sanctioned by Statute.....	21
16. Which is the Best Log Rule in Common Use?.....	22
17. Early History of Log Rules.....	22
18. Comparison of Log Rules.....	26

CHAPTER III.

DETAILED DISCUSSION OF LOG RULES.

SEC.	PAGE
19. The Champlain Rule.....	27
20. Daniels' Universal Log Rule.....	32
21. The International Log Rule.....	35
22. The Doyle Rule.....	38
23. The Scribner Rule.....	41
24. The Maine Rule.....	42
25. The Hanna Rule.....	45
26. The Spaulding Rule.....	45
27. The British Columbia Rule.....	46
28. The Drew Rule.....	46
29. The Constantine Rule.....	47
30. The Canadian Rules.....	47
31. Miscellaneous Log Rules.....	48

CHAPTER IV.

LOG RULES BASED ON STANDARDS.

32. Definition of Standard Measure.....	53
33. The Nineteen-inch Standard Rule.....	54
34. The New Hampshire Rule (Blodgett Rule).....	55
35. The Cube Rule.....	57
36. Other Standard Rules.....	57

CHAPTER V.

METHODS OF SCALING LOGS.

37. Instruments for Scaling Logs.....	60
38. Methods of Measuring the Diameters and Lengths.....	62
39. Methods of Making Discount for Defects.....	65
40. Rules for Scaling Used on the Forest Reserves.....	74

CHAPTER VI.

DETERMINATION OF THE CONTENTS OF LOGS IN CUBIC FEET.

41. Use of the Cubic Foot in America.....	76
42. The Measurement of Logs to Determine their Cubic Contents..	77
43. Measuring Instruments.....	79
44. Principles Underlying the Determination of the Cubic Contents of Logs and Trees.....	85

CONTENTS.

ix

SEC.	PAGE
45. Fundamental Formulæ.....	86
46. Determination of Sectional Areas.....	90
47. Methods of Determining the Volume of Logs by the Measurement of the End Diameters and the Length.....	91
48. Method of Cubing Logs by the Measurement of the Length and of the Diameter at the Middle.....	93
49. Method of Cubing Logs by the Measurement of the Length, the Top Diameter, and the Diameter at One-third the Distance from the Butt.....	94
50. Method of Cubing Logs by the Measurement of Two End Diameters, the Middle Diameter, and the Length of the Log.....	95
51. The Method of Fifth Girth.....	95
52. Burt's Quarter-girth Method.....	96
53. Other Methods Chiefly of Scientific Interest.....	97
54. Contents of Logs in Cubic Meters.....	98

CHAPTER VII.

DETERMINATION OF THE CUBIC CONTENTS OF SQUARED LOGS.

55. Method of Quarter Girth.....	99
56. The Two-thirds Rule.....	99
57. The Inscribed Square Rule.....	100

CHAPTER VIII.

CORD MEASURE.

58. The Measurement of Cord-wood.....	101
59. Amount of Solid Wood in a Stacked Cord.....	103
60. Relation between Cord Measure and Board and Standard Measures.....	109

CHAPTER IX.

THE CONTENTS OF ENTIRE FELLED TREES.

61. The Measurement of Entire Felled Trees.....	111
62. The Computation of Volume.....	114
63. The Measurement of Crown, Clear Length, and Merchantable Length.....	116
64. Description of the Tree Measured.....	118

CHAPTER X.

THE DETERMINATION OF THE HEIGHT OF STANDING TREES.

SEC.	PAGE
65. Rough Methods of Measurement.....	120
66. Height Measures.....	122
67. The Faustmann Height Measure.....	122
68. The Weise Height Measure.....	129
69. The Christen Height Measure.....	131
70. The Klaussner Height Measure.....	133
71. The Winkler Height Measure and Dendrometer.....	137
72. The Brandis Height Measure.....	141
73. Clinometer for Measuring Heights.....	144
74. The Abney Hand Level and Clinometer.....	145
75. Other Height Measures.....	147
76. General Directions for the Measurement of Heights of Trees ..	148
77. Choice of a Height Measure.....	149
78. The Use of Dendrometers.....	150

CHAPTER XI.

DETERMINATION OF THE CONTENTS OF STANDING TREES.

79. Estimate by the Eye.....	152
80. Estimate of the Contents of Standing Trees by Volume Tables and Form Factors.....	155
81. Rough Method of Estimating the Cubic Contents of Standing Trees.....	155
82. Hossfeldt's Method.....	155
83. Pressler's Method.....	155

CHAPTER XII.

VOLUME TABLES.

84. Definition of Volume Tables.....	158
85. Volume Tables for Trees of Different Diameters.....	159
86. Volume Tables for Trees Grouped by Diameter and Number of Logs.....	163
87. Volume Tables for Trees of Different Diameters and Merchant- able Lengths.....	164
88. Volume Tables for Trees of Different Diameters and Tree Classes.....	164

CONTENTS.

xi

SEC.	PAGE
89. Volume Tables for Trees of Different Diameters and Heights..	166
90. Graded Volume Tables.....	169

CHAPTER XIII.

FORM FACTORS.

91. Definition of Form Factors.....	174
92. The Use of Form Factors.....	176
93. Variations in the Value of Breast-height Form Factors.....	176
94. Construction of Tables of Form Factors.....	170
95. Absolute Form Factor.....	182
96. Normal Form Factor.....	182
97. The Conception and Use of Form Exponents.....	182
98. Form Height.....	184
99. Special Methods of Determining Form Factors.....	185
100. Method of Form Quotients.....	188

CHAPTER XIV.

DETERMINATION OF THE CONTENTS OF STANDS.

101. Problems of Determining the Contents of Stands.....	190
102. Timber Cruising.....	191
103. Estimate by the Eye.....	191
104. Estimate by the Inspection of Each Tree in a Stand.....	194
105. A Method Used in Michigan.....	196
106. Estimating by Working over Small Squares.....	197
107. Estimating in 40-rod Strips.....	198
108. Erickson's Method.....	198
109. Estimate by Use of Stand Tables.....	200
110. Estimate by the Use of Valuation Surveys.....	202
111. The Use of Strip Surveys.....	202
112. Distribution of the Strip Surveys.....	203
113. Data for a Forest Map.....	206
114. Measurement of the Trees.....	207
115. Recording the Measurements.....	208
116. Number of Strip Surveys Required for an Estimate.....	208
117. Advantage of Strip Surveys.....	209
118. Accurate Plot Surveys.....	209
119. Instruments Used in Laying Off Sample Plots.....	210
120. Necessary Precision in Laying Off Sample Plots.....	214
121. Shape and Size of Sample Plots.....	215

SEC.	PAGE
122. Marking the Boundaries of Sample Plots.....	215
123. Calipering.....	216
124. The Location of Sample Plots.....	216
125. Computation of Volume of the Trees on Valuation Areas.....	219
126. Determination of Volume of Stands by the Use of Felled Sample Trees.....	224
127. The Mean Sample-tree Method.....	224
128. Arbitrary Group Method.....	229
129. The Volume-curve Method.....	232
130. The Draudt Method.....	233
131. The Urich Method.....	236
132. Hartig's Method.....	240
133. Block's Method.....	240
134. Method of Forest Form Factor.....	241
135. Metzger's Method.....	241
136. Method of Absolute Form Factor.....	242

CHAPTER XV.

DETERMINATION OF THE AGE OF TREES AND STANDS.

137. The Age of Felled Trees.....	244
138. Estimate of the Age of Standing Trees.....	246
139. The Age of Tropical Trees.....	248
140. Determination of the Age of Stands.....	248
141. Economic Age.....	252

CHAPTER XVI.

THE GROWTH OF TREES AND STANDS.

142. Different Kinds of Growth.....	254
143. Tree Analyses.....	256
144. Preparation of a Felled Tree for Measurement.....	257
145. Determination of the Average Radius.....	258
146. Instruments for Measuring Diameter Growth.....	260
147. Counting the Annual Rings from the Pith Outward.....	261
148. Counting the Rings from Bark toward Pith.....	262
149. Investigations of Diameter Growth.....	265
150. Determination of Diameter Growth.....	266
151. Separate Studies Made for Trees Growing under Different Conditions.....	268
152. The Study of Diameter Growth in Even-aged Stands.....	268

CONTENTS.

xiii

SEC.	PAGE
153. The Study of Maximum Diameter Growth in Even-aged Stands.....	272
154. The Measurement of the Minimum Diameter Growth.....	273
155. Stimulated Growth after Thinning.....	274
156. Rate of Growth in Uneven-aged Stands.....	275
157. Determination of the Mean Annual Growth of Trees in Uneven-aged Stands.....	276
158. Prediction of Growth for Short Periods.....	277
159. Tables of Growth of Trees of Different Diameters.....	278
160. Study of the Growth of Trees in Area.....	282
161. The Growth in Height of Individual Trees.....	283
162. Determination of the Rate of Growth of Trees in Height....	284
163. Height Growth of Even-aged Stands.....	287
164. The Growth in Height of Trees of Different Diameters.....	288
165. Study of the Rate of Growth of Individual Trees in Volume..	290
166. Graphic Method of Determining the Average Volume Growth of a Group of Trees.....	293
167. Modification of the Method by the Author.....	295
168. Determination of Volume Growth for Short Periods.....	298
169. Pressler's Modification.....	299
170. Determination of the Growth in Volume by Means of Form Factors.....	300
171. Estimate of Volume Growth in the Future.....	300
172. The Rate of Growth Percent.....	301
173. Determination of Volume Growth Percent of Standing Trees ..	304
174. Pressler's Method.....	304
175. Schneider's Method.....	307
176. The Increment of Stands	309
177. Prediction of the Increment of Even-aged Stands for a Short Period.....	310
178. To Determine the Growth in Volume of an Entire Forest.....	314

CHAPTER XVII.

YIELD TABLES.

179. Definition of Yield Tables.....	316
180. Yield Tables for Even-aged Stands.....	316
181. European Yield Tables.....	317
182. Normal Yield Tables	318
183. Contents of Normal Yield Tables.....	320
184. Uses of Normal Yield Tables.....	321
185. Collection of Data to Construct Yield Tables.....	322

SEC.	PAGE
186. Selection of the Sample Plots.....	323
187. Necessary Number of Sample Plots.....	324
188. Thinning of the Stand before Measurement.....	324
189. Measurement of the Plots.....	324
190. Description of the Sample Plots.....	324
191. Construction of the Tables.....	325
192. Normal Yield Tables in this Country.....	326
193. Normal Yield Tables for Unthinned Pure Stands.....	327
194. Yield Tables for Thinned Stands.....	328
195. Normal Yield Tables for Mixed Forests.....	331
196. Yield Tables for Many-aged Stands.....	334
197. Necessary Field Work.....	335
198. Construction of Yield Tables.....	337
199. Indian Yield Tables for Many-aged Stands.....	338
200. Empirical Yield Tables.....	341
201. Periodic Measurement of Permanent Sample Trees and Plots..	344
202. Permanent Sample Plots in this Country.....	345

CHAPTER XVIII.

GRAPHIC METHODS USED IN FOREST MENSURATION.

203. The Use of Graphic Methods.....	349
204. Plotting of Values on Cross-section Paper.....	350
205. Construction of Curves.....	352

APPENDIX.

Legislation Regarding the Measurement of Logs.....	359
List of the Most Important Works Dealing with Forest Mensuration.	368
Tables Showing the Contents of Logs.....	375
Volume Tables for Standing Trees and Tables of Form Factors.....	402
Tables of Growth and Yield.....	416
Miscellaneous Tables.....	429

FOREST MENSURATION.

CHAPTER I.

INTRODUCTION.

1. Definition of Forest Mensuration.—Forest mensuration deals with the determination of the volume of logs, trees, and stands, and with the study of increment and yield. As usually defined it includes the measurement of standing trees, logs, and other parts of felled trees, but not the measurement and grading of any form of lumber, such as boards, shingles, staves, heading, etc. It does not deal with the measurement of such products of trees as resin, gum, sugar, tannin, etc. Forest mensuration could be extended to include the measurement and grading of lumber, but in the author's opinion this subject, like the determination of the money value of stumpage and land, should be considered under the head of lumbering.

In a systematic division of the science of forestry, mensuration falls under forest management and is often included in textbooks on that subject. Forest mensuration also touches silviculture very closely, for its principles are used in the determination of many silvical characteristics of trees, including increment and yield, form and development of the stem and crown, etc.; and the determination of the method of silviculture applicable under a given set of conditions is dependent on the results of measurements.

2. Importance of the Study of Forest Mensuration.—In many respects forest mensuration is the most important branch of technical forestry, and lies at the foundation of all practical work in the woods. The buying and selling of logs and standing timber, the valuation of forest holdings, the determination of the practicability of forestry as distinguished from ordinary lumbering, and all work of forest organization, depend on a knowledge of forest mensuration. The branch of the subject most interesting and valuable to the lumberman is that dealing with the measurement of the contents of logs and standing timber. The study of growth lies more within the province of the forester, who must be able to foretell the future yield of forests, as well as scale logs and estimate timber. The importance to the practical forester of a knowledge of timber cruising and scaling is obvious without discussion. On the other hand the value of the study of the rate of tree growth has not been clearly understood in this country.

Forestry begins with the recognition that forests have a value not merely in the trees standing at any given time, but in their power by growth to produce wood and timber in the future. The practical purpose of all study of growth is to measure this producing power of forests. The forester claims that the growth of forests can be increased by certain methods of treatment, and that in the long run the yield in money will be greater when they are so treated than when handled in the ordinary way.

Better conditions of growth can, however, be brought about only through some present outlay of money, labor, or time. This outlay may take the form of extra care on the part of the chopper in protecting young growth, a curtailment of present gains through leaving some merchantable trees for seed, an increased cost of cutting, or a direct outlay of money for protection against fire, marking the trees to be cut, planting, pruning, or other work of improvement.

In most cases the forester cannot tell whether forestry will pay until he ascertains how rapidly the trees will grow under

improved conditions, and is thus enabled to compare the results with what would take place under the usual treatment.

Some forests require treatment along the lines of forestry for other than financial reasons, as, for example, in certain public reserves and private pleasure-parks. But in most cases the measures of the forester can be advised only when they can be shown to be financially profitable, and this cannot be determined except through a knowledge of growth.

A forester's usefulness depends, therefore, not merely on his knowledge of the nature of tree life, and on his ability to establish the best conditions for rapid growth of forests, but also on his ability accurately to forecast, from the business standpoint, the outcome of his recommended measures.

Sometimes it is obvious to the forester that the improved growth will be sufficient to justify the methods of forestry, but even then his conclusions are based on a general knowledge of the growth of the trees in question. He may not be able to express his results in figures, but may still be certain that the increased growth will warrant the expenditures he recommends. As a rule, however, the forester must justify his proposals from definite data as to rate of growth rather than from general estimates.

The forester to-day is heavily handicapped on account of the lack of accurate data pertaining to growth. His recommendations as to the advisability of forestry and his proposals for various methods of handling forest lands often fail to carry conviction because he is unable to show what may reasonably be expected in the way of financial returns. The situation in southern New England may be taken as an illustration. The question constantly comes up whether it is worth while for the farmer to plant up abandoned pastures rather than to wait for the trees to come in by natural reproduction. Should such lands be planted at all, and, if so, with what species? The forester already knows that chestnut poles may be produced in forty years, but he does not as yet know how many chestnut trees

to the acre would be standing in a given locality at the end of forty years, or what proportion of them would be suitable in size and quality for poles. Not having these accurate data, he is not in a position to forecast for the farmer, better than by a random guess, the future money returns from the venture. Again, the forester does not yet know whether chestnut will yield a greater amount of timber than white pine or other fast-growing species. These questions cannot be answered until an accurate study has been made of the increment and yield of these species. Farmers and lumbermen are frequently urged to make thinnings for the improvement of the composition and growth of their woodlands. But as yet very few private owners have undertaken such improvement cuttings and in most cases have done the work experimentally and not with confidence in increased financial returns. The majority of private owners will not introduce forestry until the forester, through his study of growth, can prove that planting and all other outlays of time, labor and money will result in increased money returns.

An accurate knowledge of the subject of growth is necessary not only to decide whether the outlays involved in forest methods will yield a good financial return, but also to determine the true value of young woodlands. Their real value depends upon their power of production, and this can be ascertained in no other way than by the use of data obtained in the study of growth. At the present time cut-over land is valued in a largely arbitrary way—by a sort of guesswork or by local custom. Often two tracts of cut-over land sell for the same price per acre without regard to whether they are correspondingly well stocked with young trees. Thus a value of \$5.00 per acre may be placed upon young sprout land through custom, whereas, in fact, it may be an extremely good permanent investment at \$10.00 per acre or a very poor one at \$5.00. When a purchaser is seeking cut-over land as a permanent investment, he should have a more exact knowledge than at present of its real capability for growth. Many owners have disposed of cut-over lands which they

certainly would have held, had they known how quickly a new crop would follow. On the other hand many owners have held land for a second cutting with the expectation of securing the second crop sooner than the land is capable of producing it. Water companies and railroads often pay excessive prices when purchasing land, because they have no knowledge of tree growth.

The study of forest growth is of value in damage suits. As far as the writer is informed, damage based on the future growth of trees has never been awarded by an American court for injury to woodlands. Railroad companies are frequently sued for the recovery of damages caused by the burning of immature timber. In such cases it is apparent that the real damage is not represented by the sale value of the immature timber destroyed, but by its prospective value. Young woodland has a prospective value to its owner as truly as a young orchard of fruit-trees has to its owner; the only difference is in the character of the product. In suits against railroad companies for burning young woodland the damages awarded are at present based on guesswork rather than on the real value of the property injured.

An illustration of the destruction of young timber which has value through its capacity for growth may be taken from the pine region. Suppose that a stand of white pine, 20 years old, is destroyed by fire from a railroad. When the railroad company is sued it will contend that the damage should be based on the sale value of the standing timber destroyed, probably about 15 cords to the acre, worth not over \$15.00. The owner, on the other hand, will contend that the damage should be based not on the present but on the future value of the timber. He may justly claim that he expected to hold the property until the timber is 50 years of age, when it would yield about 50 to 55 cords of wood per acre. Of this about three fourths would be suitable for lumber and the remainder for fire-wood, worth all together \$160.00 per acre, at a conservative estimate. The true present value of the property would be determined by discounting to the present time \$160.00 and deducting therefrom the present value of all

expenses which have would been incurred before the maturity of the timber, including the annual outlay for taxes, protection, supervision, and risk.

This method of valuing woodlands has for a long time been in use in Europe. It has never been used in this country, first, because of the abundance of forests, and, second, on account of the lack of knowledge of the rate of growth of our native trees. As soon as foresters are able confidently to predict the future value of immature timber, litigants will be able to recover the true value of young woodlands when destroyed by fire or otherwise.

A knowledge of forest growth is of paramount importance to large lumber companies. Many pulp and paper companies already recognize that young spruce lands have a value on account of the future crops which they will produce. There are, in this country, many opportunities for profitable investment in second-growth timber lands. Such lands are now cheap because their value as a permanent investment is neither recognized nor understood. Thus burned-over lands in Maine may frequently be bought at a very low price. If a full crop of white birch and poplar follows the burning, an extremely profitable return would be obtained in 40 to 50 years. Of course this would be a long investment and would appeal only to stable companies of large capital, such as many of our lumber and paper companies. Cases are already on record where private owners have bought young poplar land at a very low rate and have made a large profit.

It is obvious that the capacity of young timber lands for future production can be determined only through a study of tree growth. Lumbermen seeking investments in young timber lands are entirely unable to judge of the wisdom of buying any given tract until provided with an estimate of its capacity for future production.

When better understood the question of tree growth will be the prime factor in the settlement of cases arising out of the

violation of contracts to cut timber to a specified diameter. Thus contracts are often made in the spruce sections for the cutting of trees above 10 or 12 inches in diameter. Frequently these contracts are broken by cutting all trees down to 6 or 8 inches in diameter. The owner of the land, according to the present custom, is able to collect as damages no more than the stumpage value of the trees wrongfully cut, and he receives nothing whatever for the injury to the producing power of his forest, although such wrongful cutting may have reduced the growth of the desired timber on his land 50 per cent. If the contract had been faithfully performed, his timber might have grown, after lumbering, at the rate of 100 board feet per acre per annum, whereas the growth has been reduced by wrongful cutting to 50, or even less, board feet per annum. The real damage to the land in such a case can be reached only through a knowledge of growth.

To meet these demands foresters will specialize and become recognized as experts in determining the prospective value of timber lands, and as such will be called on to testify in court in damage cases and also consulted by would-be investors in timber lands.

3. Literature.—English literature on forest mensuration is very meagre. Several works on general forestry and on forest management devote a few chapters to the subject, as, for example, Schlich's *Manual of Forestry*, MacGregor's *Organization and Valuation of Forests*, *The Forester*, by Brown and Nisbet, and Green's *Principles of American Forestry*; but none of these works treat forest mensuration fully. By far the best discussion of the subject is contained in the third volume of Schlich's *Manual of Forestry*.

The information of most value to American foresters is contained in miscellaneous books, pamphlets, bulletins, and forest periodicals, but the material is scattered and often not available when desired.

The German and French text-books are excellent. The average American forester, however, cannot read German and French

with sufficient facility to use these works. Moreover, these books do not contain a great deal of matter which an American forester must know. Every forester engaged in research should learn to read German and French in order to follow the results of foreign work in forest mensuration, much of which is of great value to us, but which cannot be entirely included in text-books.

The best foreign books are the following:

Die Holzmesskunde, by Franz Baur,
Lehrbuch der Holzmesskunde, by Udo Müller,
Leitfaden der Holzmesskunde, by Adam Schwappach,
Cubage et Estimation des Bois, by Alexis Frochot.

Of these Schwappach's book is the most useful to the average beginner.

Surprise is often expressed that the British foresters in India have not developed a more extensive literature, and that what has been written has so little reference to the practice in India. The reason why there is so little Indian literature on forest mensuration is that there has been relatively little work of research carried on in the study of growth. There is in India no central department of research, and practically all that has been done in the study of growth has been in the preparation of working plans; and as a rule the data of growth are based on relatively few measurements. The methods of mensuration, working plans, and silviculture in India are of great value to American foresters in the Philippines. It is unfortunate that a more complete account of these methods has not been presented together in a series of books.

A list of books on forest mensuration is given in the Appendix.

4. Units of Measurement.—The ordinary American units are used in the work of forest mensuration in the United States. The diameter measurements are taken in inches. Lengths of logs and trees are measured in feet. For ease in averaging and comparing the results of measurements, inches are divided into

tenths instead of eighths, and feet are divided into tenths of feet instead of into inches.

It is not necessary or desirable at the present time to use the metric system in forest work in the United States. Although clumsier than the metric system, the ordinary American units may be made fully to answer the requirements of the most exacting scientific work. The metric system has many advantages over the present American system, but the results of measurements taken in the woods, if expressed in the metric units, would be unintelligible to most persons for whose practical use the figures are designed. This does not apply to the Philippine Islands, where the metric system has already been introduced with success.

The unit of volume most commonly used in America in the lumber industry is the board foot. In small transactions, standing timber is often sold by the lot or for a specified amount per acre. Standing trees which are to be used for lumber are occasionally sold by the piece. Hoop-poles and other small wood are sold by the hundred or thousand. Ties, poles, piles, and mine props are sold by the piece, the price varying according to specifications as to diameter, length, and grade, or by linear feet.

Fire-wood and wood cut into short bolts, such as small pulp-wood, excelsior wood, spoolwood, novelty wood, heading, etc., are ordinarily measured in cords.

In the Adirondack Mountains the 19-inch standard, or as it is often called, "market", is a common unit of log measure. In some localities a log 22 inches in diameter at the small end, and 12 feet long, is used as a standard log and is the unit for buying and selling timber. In other sections standards are used which are based on logs of other dimensions, as explained in a later chapter.

In New England wagon stock is sometimes sold by the cubic foot, but the unit is not commonly used in commercial transactions in this country. When used, it is employed to measure long timber, and the results are calculated for the square sticks rather than for the full contents of the round logs. The cubic

foot, however, is commonly used in measuring precious woods imported from the tropics. Such timbers are also sold by the ton. Formerly the Spanish cubic foot was used in the Philippines, but the cubic meter is now the standard unit, as established by the Forest Act of 1904.

CHAPTER II.

THE DETERMINATION OF THE CONTENTS OF LOGS IN BOARD MEASURE.

5. Definition of Board Measure.—The unit of board measure is the *board foot*, which is a board one inch thick and one foot square. The contents of a board one inch thick are equal to the number of square feet of surface of the board's side; hence the term superficial contents which is applied to the number of board feet in lumber. Board measure is used also for measuring the contents of lumber of other thicknesses than one inch and other widths than one foot, as plank and scantling. The expression superficial contents, which originally was applied to inch boards, is now popularly applied to the number of board feet in lumber of any dimensions whatever, and also to the contents, board measure, of round logs. The number of board feet in any piece of lumber is obtained by multiplying the product of the width and thickness in inches by the length in feet and dividing by 12. It is necessary to divide by 12 because the width of the board is expressed in inches instead of feet. Thus a 2×4 scantling, 12 feet long, contains $\left(\frac{2 \times 4 \times 12}{12}\right) = 8$ board feet. Tables are constructed to show the contents of boards and scantling of all commercial dimensions. Such tables are published in a variety of forms, usually in so-called Ready Reckoners, such as those mentioned on page 369. In some localities board measure is based on boards $\frac{7}{8}$ of an inch in thickness. In this case the unit is a board one foot square and $\frac{7}{8}$ of an inch thick. Con-

siderable confusion has resulted from this deviation from the usual unit.

6. Board Measure Applied to Round Logs.—In America the contents of round logs are usually measured in board feet. This measure does not show the entire contents of logs, but the amount of lumber which it is estimated may be manufactured from them. The contents of any given log are determined from a log table showing the estimated number of board feet which can be cut from logs of different diameters and lengths. Such a table is called also a log scale or log rule.

The method of constructing a log table or rule is to reduce the dimensions of perfect logs of different sizes, to allow for waste in manufacture, and then to calculate the number of inch boards which remain.

7. Principles of Constructing Log Rules.—There are, in general, five methods of constructing log rules.

1. The method of diagrams. Full-sized circles of all diameters are drawn on large sheets of paper. Lines are drawn across to represent the boards, each being separated by a narrow band representing the saw-kerf. As many boards are fitted into the diagram as possible, assuming a specified minimum width of board and a reasonable width of slab. The contents in board feet are then calculated from these diagrams for logs of all lengths and diameters.

2. Mathematical formulæ. In this method a mathematical formula is used which reduces the dimensions of the log by an amount proportionate to its size, to cover the loss in slabbing, edging, and sawdust, and gives directly the amount of lumber in board feet. As described later these formulæ are, with a few exceptions, mathematically incorrect, and tables derived from them are of little value except as a rough approximation which is little better than the ocular estimate of a trained sawyer.

3. By the results of actual experience at sawmills. A number of log rules have been constructed from the results of actual tests at the mill. Logs of different sizes are followed through the mill

and the product of each ascertained. The results of a large number of such measurements are averaged together in the form of a log table.

4. By correcting existing log rules. Lumbermen frequently change some log rule which has proved unsatisfactory, by applying corrections to make the results conform with what their own mills actually yield.

5. By first constructing a rule in standards (see page 53) and then translating to board measure by applying a uniform converting factor to each of the values in the standard rule. As shown later, this method is incorrect.

8. Conditions Influencing the Contents of Logs in Board Feet.—The amount of lumber which actually can be cut from logs of a given size is not uniform because the factors which determine the amount of waste vary under different circumstances. These factors are as follows:

1. The thickness of the saw. A thick saw causes a greater waste in sawdust than a thin one, as, for example, a modern band-saw. The old-fashioned rotary saw cut a kerf $\frac{1}{4}$ or $\frac{3}{8}$ inch thick, while the modern band-saw cuts out $\frac{1}{8}$ inch.

2. The width of the smallest board which may be used. The narrower the board that can be utilized, the greater will be the total product of a specified log in board measure. If the width of the narrowest board that can be used is 6 inches, there is greater waste in slabbing than if 3-inch boards can be taken. In the former case a thick slab is thrown away which at its center is thick enough, but which is not wide enough, to make a board 6 inches wide. It is obvious that such slabs often would saw out a 3-inch board.

3. The thickness of the boards. A log sawed into 2-inch plank will yield a greater number of board feet than if sawed into inch boards, because there are fewer cuts and hence less waste in sawdust. If the boards are cut less than one inch in thickness, there would be even a greater sawdust waste than by sawing 1-inch boards.

4. Skill of the sawyer. Great judgment is required to cut timber in such a way as not to waste any material besides the absolutely necessary slab and saw-kerf. As a rule the sawyer must decide very quickly how a given log should be sawed, so that he must be a man of clear head, quick perceptions, and great experience. Mill-owners find it economy to hire the best available sawyers, even at very high wages.

5. The efficiency of the machinery. It is obvious that a saw which is poorly set and filed will waste more material in saw-dust than one properly handled. Cheap machinery often produces boards thicker at one end than at the other. This means that the total product from a given lot of logs will be less than could be obtained from better machinery.

6. Defects in the timber. Very few logs are perfect. In the majority of logs there is more or less waste due to crooks, rot, knots, worm-holes, or other defects.

7. Amount of taper. It is evident that logs having considerable taper will yield more than those with little or no taper, since some short boards may be cut from the wider portion of the logs.

8. Shrinkage. Boards shrink to a certain extent after sawing.

9. **Value of Board Measure Applied to Round Logs.**—The lack of uniformity in the conditions influencing the contents of logs in board feet has led to wide differences of opinion as to how log rules should be constructed. It is obvious that a rule based on a $\frac{1}{4}$ -inch saw-kerf and a given allowance for waste by edging does not give accurate measure when used with a saw of different gauge and in a mill which wastes less wood in edging than allowed by the rule. Many lumbermen have not been satisfied with such log rules as have been constructed, and have devised new rules to meet their special local requirements. The multiplication of rules has continued until there are now over forty in use in this country and Canada. The large number of rules, their inconsistencies, and the incorrect methods used

in applying some of them have led to great confusion and inconvenience; and in some cases landowners have been defrauded through the use of defective rules.

One of the sources of difficulty in log measurement is the lack of uniformity in applying any given rule. Most rules require the measurement of diameter at the small end of a given log, on the assumption that the increase at the other end is lost in slabbing. Inasmuch as the taper is thus left out of consideration, a single long log will show a different product, with a given log rule, according to the lengths and arrangement of the short logs into which it may be cut. In some cases, of course, a long log may be divided only in one way because of crooks or other imperfections which have to be avoided. But with a perfectly straight long log there may be a dozen or more methods of arranging the short lengths, and in almost every case a different product will be obtained from the log rule.

This is well illustrated by the example of two pitch pine trees measured in Pennsylvania, each having a merchantable length of forty-two feet (see table, page 16).

This table shows a variation of the scale of tree No. 1 between 149 and 181 board feet, and of tree No. 2 between 136 and 167 board feet, according to the method of cutting. The largest scale is obtained by cutting four logs. In practice, however, it would frequently be more profitable to cut three logs with a smaller scale, because of the greater expense in handling the larger number of logs.

Appreciating the facts explained above, one is inclined to advocate the abolishment of the board foot as a unit in measuring round logs. The board foot is, however, an exceedingly convenient unit. It is much simpler for the millman to know at once the actual product of logs than to be obliged to calculate the product by applying converting factors to some other unit like the cubic foot or the standard. In estimating the yield of a given tract in saw timber, in purchasing stumpage to supply a mill for a given length of time, in valuation of forest land and similar work,

Tree I.			Tree II.			Tree I.			Tree II.		
Log No.	Length of Log, Feet.	Total Scale, Bd. Ft.	Log No.	Length of Log, Feet.	Total Scale, Bd. Ft.	Log No.	Length of Log, Feet.	Total Scale, Bd. Ft.	Log No.	Length of Log, Feet.	Total Scale, Bd. Ft.
1	16		1	16		1	16		1	16	
2	14		2	14		2	16		2	16	
3	12	153	3	12	153	3	10	157	3	10	157
1	14		1	14		1	10		1	10	
2	16		2	16		2	16		2	16	
3	12	149	3	12	149	3	16	157	3	16	143
1	12		1	12		1	16		1	16	
3	14		2	14		2	10		2	10	
3	16	162	3	16	136	3	16	153	3	16	144
1	10		1	10		1	14		1	14	
2	10		2	10		2	14		2	14	
3	10		3	10		3	14	157	3	14	144
4	12	171	4	12	161						
1	10		1	10		1	16		1	16	
2	10		2	10		2	12		2	12	
3	12		3	12		3	14	159	3	14	148
4	10	175	4	10	165						
1	10		1	10		1	14		1	14	
2	12		2	12		2	12		2	12	
3	10		3	10		3	16	151	3	16	140
4	10	179	4	10	167						
1	12		1	12		1	12		1	12	
2	10		2	10		2	16		2	16	
3	10		3	10		3	14	167	3	14	140
4	10	181	4	10	158						

board measure has proved a very useful unit of contents and will not be given up.

While board measure is practical for measuring logs used for lumber, it is an unsatisfactory and incorrect unit for computing the contents of logs in shingles, lath, staves, shakes, and so on. At present lumbermen estimate roughly the number of shingles, lath, and staves contained in a thousand feet of lumber. It would be a great advantage if there were log tables showing the product in shingles, staves, etc., of logs of different diameters and lengths, just as board-foot tables show the contents of logs in inch boards;

but as far as the author is informed, no attempt has ever been made to construct such tables.

Board measure is extremely unsatisfactory for measuring the product of trees or logs in pulp-wood. Practically the whole log is used in making pulp. A solid measure should be adopted, like the standard or the cubic foot for the measurement of pulp-wood, dye-wood, etc., where the whole log is utilized.

As the value of wood increases the use of the cubic foot will undoubtedly be increased and eventually to a large extent replace the board foot as unit for logs.

10. Need of Uniformity in the Measurement of Logs.—The large number of log rules and their inconsistencies have led to a wide-spread demand for a reform which will lead to uniformity in the methods of measuring logs. There is a demand for a standard log rule which may be used in all cases of dispute and which will replace the present rules in purchasing and selling land and timber. A universal log rule is needed not only in commercial transactions, but also in scientific work of forestry, notably in investigations of the volume, growth, and yield of trees. The Government has in recent years published volume tables of standing trees, tables of growth in volume of different species, and tables showing the yield per acre of timber in different regions. Some tables are based on the Doyle, some on the Scribner, some on the Maine rules, etc. A scientific comparison of these tables is impossible because differences in results may be due to the variable differences in log rules used in computing the contents of the trees, rather than to differences in laws of growth.

It will be impossible to construct a single log rule for commercial use which would be satisfactory to all lumbermen, without modifications to meet local conditions of the forest and of manufacture. Such a rule is not proposed by the author. It is, however, perfectly possible and practical to construct a log rule showing the product of logs under the best conditions, to serve:

1. As the recognized commercial rule under the best conditions of lumbering.

2. As a standard in cases of dispute.
3. As a standard of comparison in all scientific work.
4. As a foundation for local commercial rules.

Local rules can never be altogether dispensed with as long as the board foot is used as a unit in measuring logs. A local rule showing the average yield of logs of a certain species from a certain region under given conditions of manufacture is very useful timber in estimating, and it is probable that many lumbermen will insist on local rules for buying and selling logs. Thus it would be necessary to have a local log rule for the hardwoods of the southern Appalachians, another for the second-growth timber of New England, and so on.

Local log rules are necessary just as local volume tables are necessary, as an aid in estimating and, if desired by the parties concerned, for use in timber sales; but there should at the same time be a standard which is just as definite as would be a recognized method of measuring logs in cubic feet or cords.

11. Principles of Constructing a Standard Log Rule.—Numerous attempts have been made to standardize a log rule, as is shown by the State legislation on the subject. These attempts have tended to increase the confusion because the States have adopted different rules. So far the efforts have been to select a rule from those in common commercial use. Each of these rules, however, has serious defects which makes it unfit to be a standard, and it is these defects which have prevented lumbermen from reaching an agreement as to which is the best rule.

The question will not be settled until lumbermen agree as to the purpose and the requisites of a standard rule for measuring logs.

The requisites of a satisfactory standard rule are, in the author's opinion, the following:

1. It should show the product of logs in boards one inch thick.
2. It should be based on the use of a saw cutting a specified kerf, for example $\frac{1}{4}$ inch.

3. It should include boards down to a specified minimum width, for example 3 inches.

4. Its construction should presuppose the use of good machinery and skilled sawyers.

5. It should be based on logs normally straight and sound. Logs are seldom absolutely perfect, there being nearly always some loss by crook or hidden defect. Logs normally straight and sound are then the best which are commonly found, in contrast to ideal logs which are scarcely ever encountered. An allowance in the rule should, therefore, be made to cover this loss which is practically always present.

6. It should be based on correct mathematics. This point is mentioned because many rules are mathematically unsound, as explained in the discussion of the various rules.

7. It should be based on a formula rather than on diagrams or mill scales. The objections to the use of diagrams are: (1) the values in the table increase from diameter to diameter by irregular differences; (2) the values cannot be easily corrected to conform to new or special conditions of manufacture; (3) the values cannot be easily checked as to correctness. The method of constructing log rules by tallies from a mill scale is undesirable, because it would be almost impossible to conform to the conditions and requisites mentioned above. Such a rule would almost inevitably bear the impression of local quality of timber and local conditions of manufacture. It would have temporary and only local value; and when it should become necessary to alter it to meet new conditions, the work would have to be done all over again.

The rule should be based on a mathematical formula by which the volume of the whole log, the loss by saw-kerf, slabbing and edging, and the loss by normal defects, are separately determined. The amount allowed in the formula for loss in manufacture should not be determined theoretically, but by tests at the mill. Such a formula can be corrected for different widths of saw, special dimensions of the product, and so on. At any

time one can check the values in the table or himself construct a table. But the most satisfactory feature of the method is that the exact allowance for waste in slabbing, saw-kerf, crook, etc., is known, and there is an opportunity to discuss and agree on these points, so vital to the success of a universal rule.

12. Selection of a Standard Rule.—None of the rules now in use met the requirements of a satisfactory standard rule. Two independent investigations, however, have recently been made which have clearly demonstrated the correct method of constructing log rules, and which should lead to the desired harmony in log measurement. The studies of Prof. A. L. Daniels of Burlington, Vt., and Prof. J. F. Clark of Toronto, Ont., constitute the most valuable contributions to the subject of log measurements that have been made. Each has proposed a formula to construct a standard log rule, based on the same general mathematical principles and designed to accomplish the objects of a standard rule described in the preceding section. The formulæ differ mainly in that Prof. Daniels makes no allowance for loss by crooks and disregards the taper of logs, and Prof. Clark makes a greater allowance for defects, including normal crook, and provides for a taper of one-half inch in every four feet of length. The differences between the two rules are not great, but in the author's opinion neither can be definitely proposed as the universal standard without some further study. Thus Prof. Clark's table appears to meet the requirements of the standard rule so far as pine is concerned; but it remains to be proved whether his allowance for crook and taper are applicable to southern hardwoods, cypress and other trees than pine. Prof. Daniels allows less for normal defect than Prof. Clark and this point in his formula would have to be proved by mill tests which have not yet been made in sufficient numbers. The points of difference between the two rules are capable of proof by tests. The establishment of one of these rules or of some other rule as a universal standard can be brought about only by agreement among the lumbermen and foresters, and by sub-

sequent enactment of the necessary legislation giving legal sanction to the rule.

13. Construction of Local Log Rules.—It was explained in section 10 that local log tables will be required in estimating and valuing timber and for many commercial transactions. At the present time the old rules are used for this purpose. The mill-scale studies which are being made by the U. S. Forest Service are, however, proving the old rules to be inaccurate, and in many cases unsuited even for local use. It is probable that nearly all the old rules will have to be superseded by new local rules. Where the necessity for a new local rule is proved, the new one should not be made directly from the average of the mill-scale tallies, but should rather be based on the universal rule by applying to it corrections which are determined in the local mill studies. Local log tables are necessarily more or less temporary in character, differing from the standard rule in the allowance for defects, crook, saw-kerf, thickness of slab, and so on,—factors which will in time be changed.

Local log rules will be constructed by adding to or subtracting from the values in the standard rule a certain percent or percents, the latter being determined by local mill studies.

14. Graded Log Rules.—Graded log rules show the product of logs in lumber of different grades and value. A number of such tables have been made up by the U. S. Forest Service in connection with the preparation of graded volume tables. None have as yet been published. They promise to serve a useful purpose in the valuation of logs.

15. Log Rules Sanctioned by Statute.— There are in the United States six different log rules sanctioned by State law, as follows: The Doyle rule, which is the statute log rule of Louisiana, Florida, and Arkansas; the Scribner rule, adopted by Minnesota, Idaho, Wisconsin, and West Virginia; the Spaulding rule, adopted by California; the Vermont rule; the New Hampshire rule; and the Drew rule, adopted by Washington. To this list may be added the New Brunswick, the Quebec, and the British

Columbia rules of Canada. The U. S. Forest Service has adopted the Scribner rule (Decimal C). Several lumber associations give their official sanction to certain rules; for example, the Doyle-Scribner combination rule, adopted by the National Hardwood Lumber Association, and the Drew rule, sanctioned by the Puget Sound Timbermen's Association. This official approval of different log rules only adds to the general confusion.

16. Which is the Best Log Rule in Common Use.—From the standpoint of accuracy, the Maine rule, if used with short logs, is probably the best of the Eastern rules in common use. The present methods of using it to measure long logs give unsatisfactory results, but this is due to the incorrect application of the rule, and not to defects in the log table. The Spaulding rule appears to give satisfactory results for the Pacific Coast conditions.

17. Early History of Log Rules.—The board foot as a unit of measure for sawed lumber has been used in this country for a great many years. Thus the measurement of the superficial contents of boards is described in *A Complete Treatise on the Mensuration of Timber*, by James Thompson, published in Troy, New York, in 1805. At that time, as shown in this same work, round logs were measured entirely in cubic feet, by the old Fifth Girth Formula, brought over from England. In the book above mentioned there is no reference to *log tables* or to estimating the contents of logs in board measure. The earliest mention of a log rule for board measure, known to the author, is contained in *A Table for Measuring Logs*, Anon., Portsmouth, Me., 1825. The rule, as described in this brochure, is as follows:

“Cast $\frac{1}{4}$ of the diameter of the log and then reckon as many boards as there are inches diameter, and the width of boards the same. For example, take a log 12 feet long and 12 inches through at the top, and by casting off $\frac{1}{4}$ as above mentioned it leaves 9 inches, which I call 9 boards 9 inches wide and each board makes 9 feet; and then multiply the number of boards by the number

of feet in one board and the product is 81 feet; and by the same rule you may cast any log whatsoever."

It will be seen that this is the same as the square of the three-fourths formula described on page 49.

One of the oldest formulæ for determining the board contents of logs is shown in *The Mechanic's Assistant*, by D. M. Knapen, published in New York in 1849. The rule is as follows:

"If the log be 2 feet in diameter, or less than 2 feet, allow 2 inches on four sides for the thickness of the slabs, and one-fifth for saw-calf, and one board for wane; but if the log is more than 2 feet in diameter, allow 3 inches for the thickness of each of the four slabs, and one-fifth for saw-calf, and two boards for wane. If, however, the logs are very straight and smooth, the slabs may be thinner."

For so-called market boards the rule reads:

"Market boards are usually a little less than one inch in thickness; and consequently the number of feet of market boards in a log will be greater than the number of feet of inch boards. To find the number of feet of market boards, in any log, allow one-eighth for saw-calf, and apply the above rule for inch boards with this difference."

About this same time there appeared a rule giving the same results as the present Doyle rule, reading as follows:

"From the diameter of the log, in inches, subtract 4 for the slabs. Then multiply the remainder by half itself, and the product by the length of the log, in feet, and divide the result by 8: the quotient will be the number of square feet."

This rule was published for the first time, as far as the author is informed, in *Elements of Drawing and Mensuration*, by Charles Davies, New York, 1846. These facts are interesting in view of the introduction of the Doyle rule between 1870 and 1880, which gives exactly the same results as this old rule and which was claimed to be new. Undoubtedly Mr. Doyle's formula was original, but an equivalent table had been used thirty to forty years before.

COMPARISON OF LOG RULES
SIXTEEN-

Name of Rule.	Diameter						
	6	8	10	12	14	16	18
	Board						
Champlain.....	22	43	70	105	146	193	247
Universal.....	14	32	57	89	127	172	223
Scribner *.....	18	32	54	79	114	159	213
Doyle.....	4	16	36	64	100	144	196
Holland or Maine.....	20	44	68	105	142	179	232
Hanna.....		32	51	80	117	160	213
Spaulding.....			50	77	114	161	216
New Hampshire.....	19	35	54	78	106	139	176
Humphrey or Vermont..	24	43	66	96	130	170	217
Bangor.....	23	41	69	100	137	182	238
Cumberland River.....			47	68	93	121	153
Favorite.....				64	98	142	197
Baxter.....		34	56	84	117	156	200
Square of three-fourths..	27	48	75	108	147	192	243
Square of two-thirds.....			58	85	114	150	192
Drew.....					No values given		
Herring.....		25	49	77	107	142	183
Quebec.....	16	32	59	80	120	160	213
British Columbia.....			55	84	119	160	207
New Brunswick.....				96	130	17	229
Dusenberry.....			42	68	100	136	170
Orange River.....				76	104	136	173
Chapin.....			64	84	112	144	186
Northwestern.....		33	61	77	117	170	206
Derby.....	28	49	75	110	148	195	248
Partridge.....	26	46	68	102	140	180	236
Parsons †.....	21	41	64	100	140	179	231
Ropp.....				69	109	157	211
Stillwell.....			65	96	133	176	225
Baughman's rotary saw	17	41	70	105	145	193	244
Baughman's band-saw...	20	41	73	112	156	209	270
Saco River †.....	26	49	75	108	147	192	249
Ballou.....	22	40	61	79	117	170	206
Wilson.....	23	46	67	101	144	184	244
Wilcox.....				66	101	144	180
Warner.....		30	40	62	98	128	162
Boynton.....		32	60	90	124	170	216
Carey †.....				No	values given for		
Forty-five.....		38	61	90	125	168	218
White.....		30	51	79	114	161	214
Finch and Apgar.....				74	112	157	203
Constantine.....		67	105	151	213	268	339
Ake.....		41	65	95	128	167	212
Wheeler.....	22	40	65	95	132	174	223
International (band-saw)	20	45	70	105	150	200	255

* Values for 6, 8, and 10 inches are those used by the
† Values read off from a scaler's stick.

FOR BOARD MEASURE.
FOOT LOGS.

in Inches.

20	22	24	26	28	30	32	34	36	38	40
----	----	----	----	----	----	----	----	----	----	----

Feet.

308	376	450	532	620	714	814	923	1038	1159	1287
282	347	419	497	582	674	773	878	990	1108	1234
280	334	404	500	582	657	736	800	923	1068	1204
256	324	400	484	576	676	784	900	1024	1156	1296
302	363	439	507	614	706	795	900	1026	1135	1261
272	336	416	501	576	656	741	832	933	1066	1200
276	341	412	488	569	656	748	845	950	1064	1185
217	262	313	367	426	489	557	628	704	785	870
267	320	384								
300	369	444	526	609	697	792	892			
190	229	268	320	372	427	485	548	614	685	759
248	324	392	476	562	632	725	845	920	1037	1160
250	305	366	432	504	582	665	754	848		
300	365	432	507	588	675	768	867	972		
236	285	341	400	464	533	605	684	768	854	946
below 20 feet.										
230	284	344	411	485	567	655	752	857	963	1067
280	347	420	507	580	673	760	867	947	1040	1173
261	320	386	457	535	619	708	804	906	1015	1129
300	362	432								
229	285	346	414	487	567	652	744	841	945	1054
213	258	308	360	418	480	546	616	692	769	853
233	294	374	465	563	666	777	896	1027	1161	1296
248	324	392	450	536	632	725	845	920	1037	1160
307	368	438	512	593	680	773	872	977		
288	350	416	486	564	650	738	834	998		
300	366	433	506	600	705					
272	339	413	493	579	672	771	877	989	1107	1232
261	320	385	456	533	618	715	822	934	1054	1142
310	382	457	540	633	722	822	934	1054	1142	1294
340	417	500	590	686	790	900	1022	1182	1286	1425
302	366	436	513	590	674	771				
280										
306	374	448	529	616	713	814	922			
240	313	373	446	513	592	673	754	853	973	1120
203	258	316	372	431	490	560	630			
366	322	384	450	522						
logs over 15 feet long.										
275	341	415	498	590	691	803	925	1058		
290	338	402	492	575	649	728	797			
258	318	400	474	552	624	733	840	928	1054	1181
416	507	603	708	821	942	1072	1210	1356	1511	1671
261	316	377	441	512	588	669				
277	337	404	475	553	636	725				
320	390	470	555	645	745	850	965	1085	1210	1345

Santa Clara Lumber Company, New York.

The exact date when J. M. Scribner first published his log table is not known to the author. The fourth edition was issued in 1846. It is probable that the rule is one of the oldest used in the country.

It is impossible to determine exactly when the board foot came into general use as a unit for measuring logs. Probably it was not generally used before 1820, for the works on mensuration printed before that date make no mention of log tables.

It is probable that about the middle of the century a number of different rules were constructed in different parts of the East, including the Younglove, the Parsons, the Saco River, and other rules.

The conception of using a standard log as a unit of measure is also very old. The 24-inch standard is described in Davies' *Elements of Drawing and Mensuration*, mentioned above, and reference is made to the 19-inch, 22-inch, and 24-inch standards in Knapen's *Mechanic's Assistant*. This point is also interesting as showing the custom in the early days of cutting logs 13 feet long.

18. Comparison of Log Rules.—The different log rules are compared in the table on pages 24, 25, which shows the board contents of sixteen-foot logs of different diameters. This table, including as it does all the log rules, is presented for the convenience of those wishing to make comparisons between the values obtained by different rules. It should be borne in mind, however, that some of them are really not comparable. For example, the Constantine rule can hardly be compared to the Cumberland River rule, because the former gives the whole contents without allowance even for a sawdust waste, whereas the latter is intended to cover a special amount of defects such as occur in river logs.

CHAPTER III.

DETAILED DISCUSSION OF LOG RULES.

19. The Champlain Rule.—This rule was devised by Prof. A. L. Daniels of the University of Vermont. The following description is based on certain portions of Bulletin 102 of the Vermont Agricultural Experiment Station, entitled "The Measurement of Saw Logs," and on private correspondence with Professor Daniels. In many places the author has used Professor Daniels' own language.

The Champlain log rule is developed in the following way: It is assumed that all logs are straight, round, and free from defects, and that the loss in the manufacture of the board is due only to sawdust, slabbing, and edging, and not to crooks, knots, or other blemishes. The only portion of the log dealt with is that which will make boards. The thickness of the slab is based entirely on the diameter at the smallest end, the taper of the log being disregarded; in other words, the log is considered a cylinder whose diameter is the same as the average diameter of the top end of the log. We begin, therefore, with a cylindrical log, round, straight, and of perfect quality. The solid contents in cubic feet of such a log is determined by multiplying the area of the cross-section in square feet by the length, that is, by the formula $V = \frac{\pi D^2}{4} \times L$ or $V = 0.7854 \times D^2 \times L$, in which V is the cubic volume, D the diameter, and L the length of the log. If D is expressed in inches and L in feet, it is necessary to divide the result by 144. If the log in question is 12 feet long, the formula reads

$$V = 0.7854 \times D^2 \div 12.$$

This result may be translated into board measure by multiplying by 12 on the assumption that each cubic foot contains 12 board feet, which is the case if the waste in sawdust, slabs, and edging be disregarded. The solid contents of the log in board feet is, therefore, obtained by the formula

$$Bf = (0.7854D^2L \div 144) \times 12,$$

or for a twelve-foot log

$$Bf = 0.7854D^2.$$

It will be seen by reference to section 29 that this is the same as the Constantine rule.

In the manufacture of boards two allowances for waste must be made, one for saw-kerf, and the other for slabs and edging which may be called surface waste. Consider first the allowance for saw-kerf. Suppose that the log is sawed through and through by the method sometimes called "slash-sawing," or "sawing through alive"; suppose, further, that a circular saw is used which cuts out a kerf one-quarter of an inch wide. The loss in sawdust for the log will then be one-fifth of the contents. That is, for every inch board there is a loss of one-quarter of an inch. There remains, then, four-fifths of the solid contents. Since the contents of a 12-foot log is $0.7854 \times D^2$, there remains after sawing $\frac{4}{5} \times 0.7854D^2$ or $0.62832D^2$. This represents the exact value of the untrimmed inch boards, including slabs, in a perfect log. It will be seen, however, that if the saw had cut a wider or narrower kerf, the numerical factor would have been different. In case of a band-saw which cuts a kerf of $\frac{1}{8}$ inch, the contents would be $\frac{8}{9} \times \frac{3.1416D^2}{4}$ or $0.69813D^2$.*

The waste by sawdust has now been accounted for, but no

* Expressed mathematically, a saw of any thickness, S , wastes S parts in every $1+S$ parts, and the contents of the log after sawing is $\frac{1}{1+S} \times \frac{3.1416}{4} D^2$.

allowance has been made for loss in slabbing, edging, and for such slight imperfections as are present in the most perfect logs. It is assumed that logs, whatever the diameters, have an average amount of waste in slabbing, edging, etc., proportional to the amount of surface. The amount of surface is proportional to the diameter and length. That is, a 24-inch log of a specified length has twice as much surface as a 12-inch log, and therefore the waste in slabs, edging, etc., in the former is just twice as great as in the latter. In the same way, a 16-foot log of a specified diameter has twice as much surface, and therefore twice as much waste in slabs, etc., as an 8-foot log.

In order to construct a log table, then, it is necessary to find the relation existing between the surface waste and the diameter. This proportion is obtained from the evidence of sawyers and scalers and by using diagrams as a check. After extensive investigation, Professor Daniels has concluded that the surface waste in perfect logs is equivalent to an inch board having a width equivalent to the diameter of the log; that is, for surface waste he subtracts as many board feet as there are inches in the top diameter.

The complete formula, on the basis of a saw-kerf of $\frac{1}{4}$ inch, is

$$Bf = (0.62832D^2 \times L \div 144) \times 12 - D.$$

This formula may be used for any length and diameter, or the contents of 12-foot logs may be first determined and the values for other lengths obtained by multiplying by the length and dividing by 12. The formula for 12-foot logs is

$$Bf = 0.62832D^2 - D.$$

The intimate connection should be noted that exists between this rule and the Constantine rule. Take four-fifths of the Constantine values, subtract the diameter, and one has the Champlain rule. Or add to the figures in this rule the diameter, increase by one-fourth, and one has the Constantine figures, which

THE CHAMPLAIN LOG RULE.

Diam-eter, Inches.	Length of Log in Feet.														Diam-eter, Inches.
	7	8	9	10	11	12	13	14	15	16	17	18	19		
4	3	4	4	5	5	6	6	7	7	8	8	9	9	4	
5	6	7	8	9	10	10	11	12	13	14	15	16	16	5	
6	10	11	12	14	15	17	18	19	21	22	24	25	26	6	
7	14	16	18	20	22	24	26	28	30	32	34	36	38	7	
8	19	21	24	27	30	32	35	38	40	43	46	48	51	8	
9	24	28	31	35	38	42	45	49	52	56	59	63	66	9	
10	31	35	40	44	48	53	57	62	66	70	75	79	84	10	
11	38	43	49	54	60	65	70	76	81	87	92	98	103	11	
12	46	52	59	65	72	78	85	92	98	105	111	118	124	12	
13	54	62	70	78	85	93	101	109	116	124	132	140	148	13	
14	64	73	82	91	100	109	118	127	136	146	155	164	173	14	
15	74	84	95	105	116	126	137	147	158	168	179	190	200	15	
16	84	97	109	121	133	145	157	169	181	193	205	217	229	16	
17	96	110	123	137	151	165	178	192	206	219	233	247	261	17	
18	108	124	139	155	170	186	201	217	232	247	263	278	294	18	
19	121	139	156	173	190	208	225	242	260	277	294	312	329	19	
20	135	154	173	193	212	231	251	270	289	308	328	347	366	20	
21	149	171	192	213	235	256	277	299	320	341	363	384	405	21	
22	165	188	212	235	259	282	306	329	353	376	400	423	447	22	
23	180	206	232	258	284	309	335	361	387	412	438	464	490	23	
24	197	225	253	282	310	338	366	394	422	450	478	507	535	24	
25	214	245	276	306	337	368	398	429	460	490	521	551	582	25	
26	233	266	299	332	366	399	432	465	498	532	565	598	631	26	
27	251	287	323	359	395	431	467	503	539	575	611	647	682	27	
28	271	310	348	387	426	465	503	542	581	620	658	697	736	28	
29	291	333	375	416	458	499	541	583	624	666	707	749	791	29	
30	312	357	402	446	491	535	580	625	669	714	759	803	848	30	

31	334	382	430	477	525	573	620	668	716	764	811	859	907	31
32	356	407	458	509	560	611	662	712	763	814	865	916	967	32
33	380	434	488	543	597	651	706	760	814	868	923	977	1031	33
34	404	462	519	577	635	692	750	808	865	923	981	1038	1096	34
35	429	490	551	612	673	735	796	857	918	980	1041	1102	1163	35
36	454	519	584	649	713	778	843	908	973	1038	1103	1167	1232	36
37	480	549	617	686	754	823	892	960	1029	1097	1166	1235	1303	37
38	507	580	652	724	797	869	942	1014	1087	1159	1231	1304	1376	38
39	535	611	687	764	840	917	993	1069	1146	1222	1298	1375	1451	39
40	563	643	724	804	885	965	1046	1126	1206	1287	1367	1448	1528	40
41	592	677	761	846	931	1015	1100	1185	1269	1354	1438	1523	1608	41
42	622	711	800	889	977	1066	1155	1244	1333	1422	1511	1600	1688	42
43	653	746	839	932	1026	1119	1212	1305	1398	1492	1585	1678	1771	43
44	684	782	880	977	1075	1172	1270	1368	1466	1564	1661	1759	1857	44
45	716	818	920	1023	1125	1227	1330	1432	1534	1636	1739	1841	1943	45
46	749	856	963	1070	1177	1284	1390	1497	1604	1711	1818	1925	2032	46
47	782	894	1006	1117	1229	1341	1453	1564	1676	1788	1900	2011	2123	47
48	816	933	1050	1166	1283	1400	1516	1633	1750	1866	1983	2099	2215	48
49	851	973	1095	1216	1338	1460	1581	1703	1824	1946	2068	2189	2311	49
50	887	1014	1140	1267	1394	1520	1647	1774	1901	2028	2154	2281	2408	50
51	923	1055	1187	1318	1450	1583	1715	1846	1977	2110	2241	2373	2505	51
52	960	1098	1235	1372	1510	1647	1784	1921	2059	2196	2333	2470	2607	52
53	999	1141	1284	1427	1570	1712	1851	1997	2139	2283	2425	2568	2710	53
54	1037	1185	1333	1482	1630	1778	1926	2074	2222	2371	2519	2667	2815	54
55	1076	1230	1384	1539	1693	1845	2000	2153	2307	2461	2615	2768	2921	55
56	1117	1276	1436	1595	1755	1914	2074	2234	2393	2553	2712	2872	3031	56
57	1158	1323	1488	1653	1819	1984	2150	2315	2480	2646	2811	2976	3141	57
58	1200	1370	1542	1713	1884	2056	2227	2398	2570	2741	2912	3083	3254	58
59	1241	1419	1596	1773	1950	2128	2305	2483	2660	2838	3015	3192	3369	59
60	1284	1468	1651	1835	2018	2202	2385	2569	2752	2936	3119	3303	3486	60

Copyright, 1905, by Archibald Lamont Daniels. Printed by permission of A. L. Daniels.

give the number of board feet in the solid log. If the number of cubic feet are wanted, it is only necessary to divide the figures of the Constantine rule by twelve.

Professor Daniels has devised two short rules of thumb which give nearly the same results as the Champlain rule. They are as follows:

(A) Take five-eighths of the diameter, subtract one and multiply by the diameter.

(B) Subtract one from the diameter, square, and the result is the contents of a log of that diameter 19 feet long.

Both these short rules give slightly less than the Champlain rule.

20. Daniels' Universal Log Rule.—In October, 1903, Professor Daniels published in Bulletin 102 of the Vermont Agricultural Experiment Station a new log rule which he called the Universal rule. The principles of constructing the Universal rule are exactly the same as for the Champlain rule, except that a greater allowance is made for waste in slabbing, edging, and for slight defects. The endeavor was to secure a rule which would give the contents of logs of average grade. The Champlain rule is made for perfect logs while the Universal rule is applicable to second-grade logs which have slight crooks or other blemishes, such as are not of sufficient importance to be made subject to a special discount by the scaler. Professor Daniels gives the name "roughage" to the material wasted by slabbing, edging, and slight defects. After careful study he has given as an allowance for surface waste, or roughage, an amount equivalent to a 2-inch plank, whose width is the same as the diameter of the log in question. It will be remembered that this "allowance plank," as Professor Daniels terms it, was, in the case of the Champlain rule, 1 inch in thickness. The Universal rule, expressed by formula, reads, therefore,

$$Bf = (0.62832D^2 \times L \div 144) \times 12 - 2D$$

$$= (0.62832D^2 \times L) \div 12 - 2D,$$

or for 12-foot logs,

$$Bf = 0.62832D^2 - 2D.$$

Professor Daniels' argument for choosing the value $2D$ as the width of the allowance plank is, in his own language, as follows:

"The particular value 2, which I have chosen as the thickness of the allowance plank, adapts the rule to what might be called a second-class log. So far as I can find out it makes it just safe for a buyer to take a fair ordinary lot of logs without any dickering over premium or discount. If a lot of perfect logs were offered, it might be fair for the buyer to give a small premium. Just where premiums or discounts are called for must naturally be left to the experience of the men in the business. The main point and prime advantage in using this rule is that they need pay no attention to whether the logs are large or small since the rule is a level one. The choice, therefore, of this second factor ($2D$), whether it should be 1.5 or 2 or 2.25, is, after all, as much a matter of convenience as anything in the actual business of buying and selling lumber in the log. The Universal log rule is so constructed, however, that it is very easy to get from it the figures which would have been shown if any one of these other factors had been used. Assume, for example, a log 24 inches in diameter and 12 feet long, which scales by this rule 314 board feet. In order to find what the amount would have been with the factor 1.5, we have only to add a number of board feet equivalent to one-half the diameter, expressed in inches. Thus in this case one-half of 24 equals 12 and $314 + 12 = 326$ board feet. In the same way a 12-inch log is credited by the Universal rule with 66 board feet; but if the factor were 1.5 it would scale 72 feet. This is just what the present Vermont rule allows for such a log, an amount which is considered by sawyers to be more than they can get from any but an exceptionally perfect log by careful sawing.

"In order to show the precise effect of choosing different thicknesses for the allowance plank I subjoin a small table for a

12-foot log, and different diameters, with allowance planks of different thicknesses.

Diameter in Inches.		Thickness of Plank.			
		2.5 in.	2 in.	1.5 in.	1 in.
6	Board feet	8	11	14	17
12	“ “	60	66	72	78
24	“ “	302	314	326	338
36	“ “	724	742	760	778

“I am convinced that no buyer would consent to use a rule with such figures as stand in the last two columns under 1.5 inches and 1 inch, and that no seller would want to use the column under 2.5 inches. I make this comparison for the convenience of readers and in order to give the fullest opportunity for candid criticism. First-class logs carefully sawed would probably yield the amounts scheduled under the 1.5 inches caption; but the fairness and wisdom of such a rule for general use on the generality of logs is another matter.” *

* Prof. A. L. Daniels has shown in Bulletin 102 of the Vermont Agricultural Experiment Station how any given rule may be expressed by a formula as follows:

“For logs of the same length the total volume varies as the square of the diameter, and the trimmings, for reasons mentioned above, as the first power of the diameter. The amount of board feet, therefore, is a quadratic function of the diameter, a function of the form $B = aD^2 + bD + c$.

“When now the proper values are assigned to the constants a , b , and c , the scale can be computed by arithmetic. These volumes are easily determined when the printed scale is given, as follows: Take, for example, from Doyle’s rule the amounts for a 12-foot log corresponding to the diameters 10 inches, 20 inches, 30 inches, successively, and we have:

$$\begin{aligned} 27 &= 100a + 10b + c, \\ 192 &= 400a + 20b + c, \\ 507 &= 900a + 30b + c, \end{aligned}$$

from which we can easily deduce the values $a = 0.75$, $b = -6$, $c = 12$, and Doyle’s formula reads: $B = 0.75D^2 - 6D + 12$.

21. The International Log Rule.—This log rule is the result of recent investigations by Professor Judson F. Clark, Forester of the Department of Lands and Forests, Ontario. It is designed for use with a band-saw, cutting a saw-kerf of $\frac{1}{8}$ inch. The rule is based on the formula: $Bf = 0.22D^2 - 0.71D$, in which the first term, $0.22D^2$, represents the contents in board feet of a log 4 feet long, after deducting the loss in saw-kerf and shrinkage in seasoning, and the second term, $0.71D$, is the waste due to square edging and to normal crook. The principles underlying the derivation of this formula are as follows:

1. An allowance of $\frac{1}{8}$ inch is made for saw-kerf, and $\frac{1}{16}$ inch for shrinkage and unevenness in sawing. After deducting for this loss, the contents in board feet of a 12-foot log are $\frac{16}{19} \times \frac{\pi D^2}{4} = 0.66D^2$; and for a 4-foot log, $0.22D^2$.

2. The minimum board is 3 inches in width, containing not over 2 board feet. A 3-inch board must, then, be at least 8 feet long to be included; a 4-inch board, 6 feet long; a 5-inch board, 5 feet long; a 6-inch board, 4 feet long.

3. An allowance is made for a taper of $\frac{1}{4}$ inch for each 8 feet of length. Professor Clark has shown that this is a conservative allowance for merchantable logs of all species so far studied in this country, including white pine, loblolly pine, spruce, balsam-fir, chestnut, and northern hardwoods.

4. Provision is made for the loss due to normal crook and that due to human and mechanical imperfections. By normal crook

“ In the same manner we obtain the others, which are subjoined.

Universal	$B = 0.62832D^2 - 2D.$
Doyle	$B = 0.75D^2 - 6D + 12.$
Vermont	$B = 0.50D^2.$
New Hampshire	$B = 0.41D^2 - 0.1D + 1.$
Hanna	$B = 0.61D^2 - 1.7D - 6.$
Bangor	$B = 0.62D^2 - 1.1D - 1.$
Holland, or Maine	$B = 0.635D^2 - 1.45D + 2.$
Drew of Puget Sound	$B = 0.615D^2 - 4.125D + 29.$
Scribner	$B = 0.555D^2 - 0.55D - 23.”$

DETAILED DISCUSSION OF LOG RULES.

31	385	435	485	540	590	640	695	745	800	850	905	960	1015	31
32	410	465	520	575	630	685	740	795	850	910	965	1025	1080	32
33	440	495	555	610	670	730	790	850	905	970	1030	1090	1150	33
34	470	530	590	650	715	775	840	900	965	1030	1095	1160	1225	34
35	495	560	625	690	755	825	890	955	1025	1095	1160	1230	1300	35
36	525	595	665	735	800	875	945	1015	1085	1160	1230	1305	1375	36
37	560	630	705	775	850	925	1000	1075	1150	1225	1300	1380	1455	37
38	590	665	745	820	895	975	1055	1135	1210	1295	1375	1455	1535	38
39	620	705	785	865	945	1030	1110	1195	1280	1365	1450	1535	1620	39
40	655	740	825	910	995	1085	1170	1260	1345	1435	1525	1615	1705	40
41	690	780	870	960	1050	1140	1230	1325	1415	1510	1605	1700	1795	41
42	725	820	915	1010	1100	1200	1295	1390	1490	1585	1685	1785	1885	42
43	760	860	960	1060	1155	1260	1360	1460	1560	1665	1770	1870	1975	43
44	800	900	1005	1110	1215	1320	1425	1530	1635	1745	1855	1960	2070	44
45	835	945	1055	1160	1270	1380	1490	1600	1715	1825	1940	2050	2165	45
46	875	990	1100	1215	1330	1445	1560	1675	1790	1910	2030	2145	2265	46
47	915	1035	1150	1270	1390	1510	1630	1750	1870	1995	2120	2240	2365	47
48	955	1080	1205	1325	1450	1575	1700	1830	1955	2085	2210	2340	2470	48
49	1000	1125	1255	1385	1510	1645	1775	1905	2040	2170	2305	2440	2575	49
50	1040	1175	1310	1440	1575	1715	1850	1985	2125	2265	2400	2540	2680	50
51	1085	1225	1360	1500	1640	1785	1925	2070	2210	2355	2500	2645	2790	51
52	1125	1275	1420	1565	1710	1855	2005	2150	2300	2450	2600	2750	2905	52
53	1170	1325	1475	1625	1775	1930	2085	2235	2390	2545	2705	2860	3015	53
54	1220	1375	1530	1690	1845	2005	2165	2325	2485	2645	2810	2970	3135	54
55	1265	1430	1590	1755	1915	2080	2245	2410	2580	2745	2915	3085	3250	55
56	1315	1480	1650	1820	1985	2160	2330	2500	2675	2850	3025	3200	3375	56
57	1360	1535	1710	1885	2060	2240	2415	2595	2770	2955	3135	3315	3495	57
58	1410	1590	1775	1955	2135	2320	2505	2685	2870	3060	3245	3435	3620	58
59	1460	1650	1835	2025	2210	2400	2590	2780	2975	3165	3360	3555	3750	59
60	1510	1705	1900	2095	2290	2485	2680	2880	3075	3275	3475	3680	3880	60

is meant the average crook of first-class logs accepted at the average mill. The average crook allowed in the rule is about 1.5 inches, and does not exceed 4 inches in 12 feet. Any crook more than 4 inches would have to be specially discounted by the scaler. Professor Clark first estimated this loss theoretically and then proved his computations by extensive tests at the mill. His studies showed that the waste due to crooks and surface imperfections is, like the waste in square-edging, directly proportional to the diameter of the log.

The necessary allowance for waste in edging, crooks, etc., amounts altogether to $2.12D$ for 12-foot logs, or $0.71D$ for 4-foot logs. This allowance was determined by mathematical computations and by tests at the mill. With these principles established, the log table was compiled by first computing the contents of logs 4 feet long and then of logs of other lengths, allowing a taper of 1 inch in 8 feet.

The International rule may be applied in mills which use saws cutting kerfs of other widths than $\frac{1}{8}$ inch, by adding to or subtracting from the total scale a certain percentage, as indicated in the following table:

For $\frac{7}{8}$ -inch kerf add	1.3%
“ $\frac{3}{8}$ “ “ subtract	5.0%
“ $\frac{1}{2}$ “ “ “	9.5%
“ $\frac{5}{8}$ “ “ “	13.6%
“ $\frac{3}{4}$ “ “ “	17.4%
“ $\frac{7}{8}$ “ “ “	20.8%

22. The Doyle Rule.—This rule is known in some sections as the Connecticut River rule, the St. Croix rule, the Thurber rule, the Vannoy rule, the Moore and Beeman rule, Ontario rule, and the Scribner rule. It is often called the Scribner rule because it is now printed in Scribner's Lumber and Log Book. The Doyle rule is used throughout the entire country and is more generally employed than any other rule. It is the statute rule of Arkansas, Florida, and Louisiana.

It is constructed by the following formula: Deduct 4 inches from the diameter of the log as an allowance for slab; square one-quarter of the remainder and multiply the result by the length of the log in feet. This formula does not explain the principle of the rule as well as that published over 50 years ago, giving the same results, namely: Deduct 4 inches from the diameter for slabs, then squaring the remainder, subtract $\frac{1}{4}$ for saw-kerf and the balance will be the contents of a log 12 feet long, from which the others may be obtained by proportion. The principle is first to deduct a 2-inch slab regardless of the size of the log; then to square the diameter to obtain the number of the square inches on the end of the stick; deduct $\frac{1}{4}$ for saw-kerf, then divide by 12. The result is the number of board feet in a log 1 foot long. If the last division by 12 be omitted, the contents of a 12-foot log will result.

The important feature of the formula is that the width of slab is always uniform regardless of the size of the log. This waste allowance is altogether too small for large logs and excessive for small ones. The principle is, therefore, mathematically incorrect. The product of perfect logs of different sizes follows an entirely different mathematical law from that of the Doyle rule. It is astonishing that this incorrect rule which gives ridiculous results for very large and very small logs, should have such a general use.

Without doubt the rule has happened to yield fairly accurate results where the loss by defects in the timber and waste in milling have accidentally about balanced the inaccuracies of the rule. Generally millmen recognize the failings of the rule and make corrections to meet their special conditions.

The opinions of a number of millmen regarding the rule are pertinent at this point. The following are selected from letters from a very large number of men all over the country. It should be added that the reason for such wide differences in the percentage of inaccuracy is on account of differences in local defects of the timber sawed.

"The saw bill will overrun the scale when the log is 20 inches and under in diameter and will begin to fall short of the scale when it reaches 24 inches in diameter, and the larger the log the more it falls short."—Mill located in Ohio.

"Large logs have to be very straight and good to hold out, and according to our experience Doyle's Rule might be increased 10% to 16 or 17 inches diameter, and from that up to 24 inches remain as it is and about 24 inches reduce 2 to 5%."—Mill in Indiana.

"Pine, spruce, and tamarack overrun the scale 20%; maple, ash, hemlock 5%."—Massachusetts.

"Small logs overrun 20%; large logs lose 20%."—West Virginia.

"Fir: large logs fall short of scale 5%, small overrun 10%."—Washington.

"Logs 12 inches and less overrun the scale about 40% for straight, clear logs.

"Logs 12-20 inches overrun the scale about 15-20% for straight, clear logs.

"Logs 20-24 inches overrun the scale about 10-20% for straight, clear logs.

"Logs 24-30 inches overrun the scale about 5-10% for straight, clear logs.

"Logs 30-36 inches about hold up the scale.

"Logs 36 and over fall below the scale."—Mill in Ohio.

"Poplar, chestnut, spruce, hemlock hold out. Cherry under-runs about 5%. Sycamore underruns 12½%. White oak cut into car stock overruns 12%. Red oak cut into lumber under-runs 5%. Rock oak underruns 10%."—West Virginia.

The Doyle rule may be found in:

Scribner's Lumber and Log Book. G. W. Fisher, Rochester, N. Y.

The Woodsman's Handbook, by Henry S. Graves, Bull. No. 36, Bureau of Forestry, Washington, D. C.

The instructions given in Scribner's Lumber and Log Book are to measure the log at the middle. In practice the logs are measured at the small end inside the bark, except long logs, which are measured at the middle. One of the writer's correspondents measures the diameter of a long log at one-third the

distance from the small end. Long logs are those containing two or more short logs of merchantable length.

23. The Scribner Rule.—This is the oldest log rule now in general use. It was originally published in *The Ready Reckoner*, by J. M. Scribner. It is now usually called the “Old Scribner Rule.” It is used to some extent in nearly every state, and is the statute rule of Idaho, Minnesota, Oregon, Wisconsin, and West Virginia. The rule was based on computations derived from diagrams drawn to show the number of inch boards that can be sawed from logs of different sizes after allowing for waste. The following description of the rule is taken from the edition of 1846:

“This table has been computed from accurately drawn diagrams for each and every diameter of logs from 12 inches to 44, and the exact width of each board taken after being squared by taking off the wane edge and the contents reckoned up for every log, so that it is *mathematically certain* that the true contents are here given, and both buyer and seller of logs will unhesitatingly adopt these tables as the standard for all future contracts in the purchase of sawlogs where strict honesty between party and party is taken into account. In these revised *computations* I have allowed a thicker slab to be taken from the larger class of logs than in the former edition, which accounts for the discrepancy between the results given in these tables and those in former editions.

“The diameter is supposed to be taken at the small end, inside the bark, and in sections of 15 feet, and the fractions of an inch not taken into the measurement. This mode of measurement, which is customary, gives the buyer the advantage of the swell of the log, the gain by sawing it into scantling, or large timber, and the fractional part of an inch in the diameter. Still it must be remembered that logs are never straight and that oftentimes there are concealed defects which must be taken as an offset for the gain above mentioned. It has been my desire to furnish those who deal in lumber of any kind with a set of tables that can

implicitly be relied upon for correctness by both buyer and seller, and to do so I have spared no pains nor expense to render them perfect; and it is to be hoped that hereafter these will be preferred to the palpably *erroneous* tables which have hitherto been in use. If there is any truth in mathematics or *dependence* to be placed in the estimates given by a diagram, there cannot remain a particle of doubt of the accuracy of the results here given."

The judgment of most sawyers with whom the author has talked is that the Scribner rule gives very fair results for small logs, but that for large logs, for example those above 28 inches, the results are too small if the logs are free of defects. It often happens that defects are greater with large logs than with small ones, because the former are from trees which are older and more apt to be mature or overmature than small trees. Scribner's rule is fairly satisfactory in such cases. The results for the small sound logs are fairly accurate and the defects of the larger logs is balanced by the deficiencies of the rule. Sometimes the Scribner rule is converted into what is known as the Scribner Decimal rule by dropping the units and rounding the values to the nearest tens. Thus 107 board feet would be written 11 in the decimal rule; 104 would be written 10. The Hyslop rule is practically the same as the Scribner Decimal rule.

The original rule did not give values below 12 inches. A number of lumber companies have interpolated for their own use the values for small logs. Thus the figures for small diameters in the table on page 24 are those used by a company in the Adirondacks. The Lufkin Rule Company publishes three tables for the scale of small logs by the Scribner rule. These are called Decimal A, B, and C.

The rule is now published in the following books:

Scribner's Rule for Log Measurement. George W. Fisher, publisher, Rochester, N. Y. Price 30 cents. The Woodsman's Handbook, by Henry Solon Graves. Bulletin No. 36, Bureau of Forestry, Washington, D. C.

24. The Maine Rule.—This is also known as the Holland rule,

and as Fabian's rule. Its use is restricted to northern New England, chiefly to Maine, where it has long been the principal log rule.

The Maine rule was constructed by the use of diagrams representing the small ends of logs of all diameters from 6 to 48 inches. The inscribed square of the logs was first determined, and the contents of the logs were then computed by allowing 1 inch for each board and one-fourth of an inch between the boards for saw-kerf. The boards outside the square were reckoned, if not less than 6 inches in width; otherwise the whole slab was discarded.

In judging this rule it must be remembered that it was devised for the measurement of short logs and not for long logs, to which it is now so frequently applied. Millmen very generally agree that the Maine rule is extremely satisfactory for short logs. In fact, it probably comes nearer satisfying the present requirements of a modern sawmill than any of the other rules in common use. It gives considerably larger results than the Scribner, Hanna, and Spaulding rules.

Like the Scribner rule the values in the Maine rule run irregularly. It is a very simple matter to correct these irregularities by graphical interpolation. Mr. H. D. Tiemann has prepared a corrected form of the Maine rule as given in the table on page 44.

The chief trouble with the rule is not due so much to defects in the values as to the present method of applying it. As explained in section 37, logs over 30 feet are measured as two logs, the diameter at the small end being measured and the diameter at the middle being estimated.

An illustration of the working of the rule is given by Mr. Austin Cary in the Report of the Forest Commission of Maine, 1896:

"Even when the present method of scaling by the Maine rule is conscientiously applied it leads to wasteful lumbering. A good example is that of a spruce log, cut in Maine, 32 feet long and scaled as 169 board feet by the Maine rule. If the loggers had cut this particular log 40 feet long the scale would have

MAINE RULE.
(Values Made Regular by Interpolation.)

Diameter, Inches.	Length in Feet.							
	10	12	14	16	18	20	22	24
	Board Feet.							
6	13	15	17	20	22	25	27	29
7	19	23	26	30	34	38	42	45
8	26	31	36	42	47	52	58	63
9	34	41	47	54	61	68	75	82
10	43	51	59	68	76	85	93	102
11	52	62	73	83	93	104	114	125
12	62	75	87	99	112	124	136	149
13	73	88	102	117	132	146	161	176
14	85	102	119	136	153	170	187	204
15	98	118	137	157	176	196	216	235
16	112	135	157	180	202	225	247	270
17	128	154	179	205	231	256	282	307
18	145	175	204	233	262	292	321	350
19	164	197	230	263	296	329	362	395
20	184	221	258	295	332	369	406	443
21	205	247	288	329	370	411	452	494
22	228	274	319	364	410	455	501	547
23	252	302	352	403	453	503	554	604
24	277	332	387	443	498	553	609	664

been only 168 board feet, or 1 foot less, although 8 feet longer and containing 5 cubic feet more. The contractor gained by wasting 8 feet of wood entirely suitable for saw lumber or pulp. Other facts about this tree are shown in the table below and illustrate the tremendous range of results depending on the different methods of applying a single specified rule:

Log as cut, 32 feet long; contents with bark, 31 cubic feet; scaled as two 16-foot logs, giving butt log 1 inch rise.	169 ft.
Scaled as two 16-foot logs, giving butt log actual rise.	185 "
A 16-foot log above, that might have been taken, scales.	31 "
Log if cut 40 feet long; contents with bark, 36 cubic feet; scaled as two 20-foot logs, giving butt log 2 inches rise.	168 "
Scaled as two 20-foot logs, giving butt log actual rise.	195 "
Scaled as four 10-foot logs, using actual top diameter of each.	216 "
Whole tree, sawed down at 1½ feet from ground and taken up to 6 inches diameter; contents, 43 cubic feet; scaled in 16-foot lengths from butt up with actual diameter.	226 "
Total contents of the tree's stem, 46 cubic feet."	

This illustration is sufficient to show what absurd results may be obtained if the rule is loosely applied, as is customary in practice.

The Maine rule may be obtained from V. Fabian, Milo Junction, Maine.

25. The Hanna Rule is used in Pennsylvania, Tennessee, Virginia, New York, and Massachusetts, and locally elsewhere. It was computed from diagrams drawn for every size of log from 8 to 50 inches in diameter. Practical millmen were consulted by the author of the rule to check the results. This rule was constructed on the same general principles as the Scribner, Maine, and Spaulding rules and its results, like those rules, are fairly satisfactory for logs of average size. The use of the rule among practical millmen is on the increase. The rule follows closely the Scribner rule, but is less erratic. When the two are compared the Hanna rule appears like an attempt to correct the eccentricities of the Scribner rule.

26. The Spaulding Rule.—This is the statute rule of California adopted by an act of the Legislature in 1878. The revised statute is quoted in the Appendix.

This rule was constructed from diagrams. Its author has given no adequate description of how the results were obtained. The only description of the construction of the rule as published by its author is as follows:

“Each sized log has been scaled so as to make all that can be practically sawed out of it, if economically sawed. Each log to be measured at the top or small end, inside of the bark, and if not round, to be measured two ways—at right angles—and the average taken for the diameter. Where there are any known defects, the amount to be deducted should be agreed upon by the buyer and the seller, and no fractions of an inch to be taken into the measurement.”

“In the foregoing table I have varied the size of the slab in proportion to the size of the log, and have arranged it more particularly for large logs by taking them in sections of 12 feet and

carrying the table up to 96 inches in diameter. As there has never been any in use for scaling over 44 inches, it has been my purpose to furnish a table for the measuring of logs that can be implicitly relied upon for correctness by both the buyer and seller; and to do so, I have spared no pains or expense to render it perfect."

The rule gives very fair results for logs which are sound. Where the run of logs is defective, the scale overruns the saw bill. As far as the author can learn, the millmen are satisfied with the rule.

It may be obtained from N. W. Spaulding Saw Company, 18 Fremont Street, San Francisco, California.

27. The British Columbia Rule.—The province of British Columbia has established a statute log rule which is based on the following mathematical formula: For logs up to 40 feet in length deduct $1\frac{1}{2}$ inches from the diameter at the small end inside the bark; square the result and multiply by the decimal 0.7854; from the product deduct three-elevenths; multiply the remainder by the length of the log and divide by 12. For logs over 40 feet in length an allowance is made on half the length of the log in order to compensate for the increase in diameter. This allowance consists of an increase in the diameter at the small end of the log of 1 inch for each 10 feet in length over 40 feet. Thus for logs 51 to 60 feet long the contents of half the log are computed by the diameter at the small end. The other half is considered to have a diameter 1 inch larger.

The British Columbia log table is published in a small booklet entitled *The British Columbia Log Scale*, and may be secured in Victoria, B.C., at the cost of \$2.00.

28. The Drew Rule.—This rule has been adopted as a statute rule in the State of Washington. The law establishing it is given in full in the Appendix. It is also the official log rule of the Puget Sound Timbermen's Association. It is used only in the north-western states and is confined chiefly to Washington. No information is given in the published rule as to how the values were

derived. The rule may be obtained in the form of a small leather-bound booklet for \$2.50 in Seattle.

29. The Constantine Rule.—This is a theoretical rule, which gives the solid contents, expressed in board feet, of logs without any reduction for waste in sawdust, slabbing, edging, etc. The principle of the rule is to determine, first, the solid contents, in cubic feet, of cylinders of different diameters. These results are then translated into board feet by multiplying by 12, on the principle that if there is no waste in sawing, there will be in each cubic foot 12 board feet. Of course, it is really not proper to express the solid contents of a log in board feet, because the board foot represents a manufactured product, and it is impossible from a cubic foot of round timber to saw 12 board feet. As it stands, therefore, the Constantine rule can hardly be considered a log rule, but only a mathematical step in the derivation of a log rule. The formula for constructing a table for this rule is as follows:

Square the diameter of the small end of the log inside the bark and multiply by the decimal 0.785; multiply the result by the length of log and divide by 12. Expressed algebraically,

$$Bj = \left[\frac{\pi D^2}{4} \times L \div 144 \right] \times 12,$$

$$Bj = 0.7854 D^2 \times L \div 12.$$

A practical board rule is sometimes made from the Constantine table by deducting a third or fourth from the figures for saw-kerf and other waste. This rule is also used as a foundation for the Champlain and Universal rules of Professor Daniels.

30. The Canadian Rules.—A number of the American log rules are used in Canada, but those recognized by statute or custom are the Quebec rule, the New Brunswick rule, the British Columbia rule, and the so-called Ontario rule, which is the same as the Doyle rule. The British Columbia rule has already

been discussed in connection with the Pacific Coast rules. The author has been unable to learn exactly how the Quebec and New Brunswick rules were constructed. As far as the author is informed, the Canadian rules, except, of course, the Doyle rule, have never been used in this country.

31. Miscellaneous Log Rules. The construction of the *Vermont Rule* is described in the Appendix. It still has some use in the northeastern states, being retained chiefly because it is a State rule. An effort is now being made to replace it by a new rule, it being considered unsatisfactory by most lumbermen. It is also called the Humphrey rule and the Winder rule.

The Baughman Rules.—These rules, devised by H. R. A. Baughman, of Indianapolis, have been constructed to show the full contents, in board measure, of perfect logs manufactured by modern machinery; one to be used with a rotary saw, and the other with a band saw. They are based on diagrams. As in other diagram rules, the values increase by irregular differences. It is, however, one of the few rules which do not allow an excessive amount for waste. Its values are, for small logs, almost identical with those of the Champlain rule. The Baughman rules are contained in Baughman's Buyer and Seller, Indianapolis, Ind., 1905. Price \$1.50.

The *Baxter rule* is used chiefly in Pennsylvania. According to Prof. J. T. Clark it is based on the formula: Subtract 1 from the diameter inside the bark at the small end, square the remainder and multiply by 0.52, and the result is the contents of a 12-foot log.

The *Dusenberry Rule* is used in Pennsylvania, New York, Ohio, and Indiana. It was made originally for white pine, but is now used also for other timbers.

The *Favorite*, or *Lumberman's Favorite Rule*, is used in Virginia, West Virginia, Michigan, New York, Texas, Tennessee, Indiana, Pennsylvania, North Carolina, and Missouri. It is probably based upon diagrams.

The *Square of Two-thirds Rule*, which is also known as the St.

Louis Hardwood rule, the Two-thirds rule, the Tennessee River rule, and the Lehigh rule, is used in Tennessee, Pennsylvania, North Carolina, Kentucky, Illinois, Indiana, New Jersey, Virginia, and West Virginia, and probably in some other states. It is based on the following formula: Deduct one-third of the diameter at the small end of the log inside the bark for saw-kerf and slab, square the remainder, multiply by the length, and divide this product by 12. The result is the contents in board feet.

The *Square of Three-fourths Rule*, whose other names are the Portland scale, the Noble and Cooley rule, the Cook rule, the Crooked River rule, and the Lumberman's scale, is occasionally used in the northeastern states. The formula upon which it is based is as follows: Deduct one-fourth of the diameter at the small end of the log inside the bark for saw-kerf and slab, square the remainder, multiply by the length of the log, and divide this last product by 12 for the contents in board feet.

The Cumberland River Rule is known in some parts of the country as the Evansville rule and the Third and Fifth rule. It is used in Tennessee, Kentucky, Indiana, Ohio, Michigan, Illinois, Massachusetts, and probably in some other states.

It is based upon the following formula: Deduct one-third from the diameter at the small end inside the bark to reduce the round log to square timber. Then from one side of the square thus obtained deduct one-fifth for saw-kerf; multiply the remainder by the side of the square and the product will be the contents of a log 12 feet long. For logs of other lengths multiply by the length and divide by 12. This rule was constructed for the measurement of hardwood logs in the water in the Mississippi River and its tributaries. These logs are often defective and in the water it is impossible to distinguish the defects which are hidden by the water itself, by mud, sand, plugs, etc. The log rule is supposed to allow for all such hidden defects.

The Herring Rule, which is also called the Beaumont rule, is used in Texas. It was first published in 1871 by T. F. Herring, Beaumont, Texas, and afterwards enlarged by W. A. Cushman

of Beaumont. No intimation is given of exactly how the table was constructed. It is probable that it is based partly on the actual cut of the logs at the mill and partly on diagrams.

The rule may be obtained from Mark Weiss, Beaumont, Texas. Price \$1.00.

The *Orange River Rule* is also known as the Ochiltree rule and as the Sabine River rule. It is used in Texas. It is based on the following formula: Multiply the square of the diameter of the small end of the log inside the bark by the length of the log and divide the product by 30; the result is the contents in board feet.

The Combined Doyle and Scribner Rule.—This is a combination of the Scribner and Doyle Rules. It is used in New York, New Jersey, Pennsylvania, Virginia, Tennessee, Kentucky, Alabama, Louisiana, Arkansas, Mississippi, Missouri, Indiana, Illinois, Michigan, Ohio, Iowa, Wisconsin, Montana, Idaho, South Dakota, and probably elsewhere. It has been adopted as the official scale of the National Hardwood Lumber Association, St. Louis, and is published in their "Grading Book." The values for diameters under 28 inches are taken from the Doyle rule; those for 28 inches and over from the Scribner rule.

The effort seems to have been to find a rule which gives very small results, in order to cover loss in defective timber. The principal use is with the hardwoods, which are apt to be unsound. It is to be counted as one of the rules designed for a special class of timber.

The *Chapin Rule* is based on measurements of logs actually sawed into lumber. It is claimed that it gives the greatest amount of lumber which can be manufactured from straight smooth logs. It is a comparatively new rule and has not yet come into very general use. It may be purchased from the American Lumberman, Chicago.

A number of other rules are in local use. They are as follows:

The *Northwestern Rule*, used to some extent in Michigan and Illinois.

The *Derby Rule*, also known as the Holden and Robinson rule, which is used in Massachusetts.

The *Partridge Rule*, also called the Murdoch and Fairbank rule, which is used rarely in Massachusetts and which is based on $\frac{7}{8}$ inch boards.

The *Preston Rule*. This is based upon the principle that one-fifth of the contents of a log should be deducted for saw-kerf. The waste in slabs is calculated by deducting $1\frac{3}{4}$ inches for small logs and $1\frac{1}{2}$ inches for large logs. The results are given in board feet and inches.

The *Parsons Rule*, used in a few places in Maine.

The *Ropp Rule*, used in Illinois. It is based on the following formula: Subtract 60 from the square of the diameter of the small end of the log inside the bark, multiply the remainder by half the length of the log, and point off the right-hand figure.

The *Stillwell Rule*, known as the Stillwell Vade Mecum rule, used by its author in Georgia.

The *Saco River Rule*, used in Maine.

The *Wilson Rule*, used in Massachusetts.

The *Ballou Rule*, used by M. E. Ballou & Son, of Becket, Mass., in measuring small hardwood timber, such as basket ash.

The *Wilcox Rule*, used locally in Pennsylvania for softwood timber.

The *Warner Rule*, used locally in New York.

The *Boynton Rule*, based upon a compromise of the Vermont and the Scribner rules and adjusted by sawyers' tallies. It is used in Vermont.

The *Carey Rule*, used in Massachusetts.

The *Forty-five Rule*, used in New York. It is based upon the following rule: For a 24-inch log multiply the square of the diameter, namely 24, by the length of the log and the result by 45, then point off three places. The figures at the left of the decimal point will represent the contents in board feet. For every variation of 2 inches in the diameter from the standard

24-inch log add or subtract 1 from the number 45 in the formula, according as the diameter is larger or smaller than 24 inches.

The *White Rule*, used to a limited extent in Montana.

The *Finch and Apgar Rule*, published in the Excelsior Log Book Table, New York.

The *Ake Rule*, used locally in Clearfield County, Pa. It is based upon the following rule of thumb: Multiply the diameter of the log, measured at the small end inside the bark, by 0.7; square the result; multiply the product by the length of the log and divide by 12. The final result will be the contents in board feet.

The *Younglove Rule* is a very old rule formerly used in New England and probably still occasionally employed in Massachusetts.

Other rules may be in existence, but they are unknown to the author.

CHAPTER IV.

LOG RULES BASED ON STANDARDS.

32. Definition of Standard Measure.—It was shown on page 26 that the custom of using a standard log of specified dimensions as a unit of volume has been used for over fifty years. A table of standards is based on the principle that the contents of logs vary directly as their lengths and the squares of their respective diameters. To obtain the volume of any given log in terms of a specified standard, square the diameter at the small end and divide by the square of the diameter of the standard log; then divide by the length of the standard log and multiply by the length of the log measured. Thus if the standard is a log 12 feet long and 24 inches in diameter at the small end, the square of the diameter of the log measured is divided by the square of 24 and then multiplied by a fraction whose numerator is the length of the given log and denominator the length of the standard. Expressed algebraically, the rule for determining the volume of a log in standards is

$$V = \frac{D^2}{d^2} \times \frac{L}{l},$$

in which V is the volume of the log, D its diameter at the small end, L its length, d and l the diameter and length of the standard.

It will be noticed that in this formula the full contents of the standard and of the log are not compared, but the contents of cylinders having diameters equal to the diameters of the respective logs at the small end. If the full contents of the logs were

to be compared, it would be necessary to take the measurements of diameter at the middle. This will be clear by reference to the formula for determining the solid contents of logs described in section 47.

33. The Nineteen-inch Standard Rule.—One of the standards in most common use is the so-called 19-inch standard, or *market*. The unit is a log 13 feet long and 19 inches in diameter at the small end inside the bark. On the principle that the contents of logs vary as the squares of their diameters, a 10-inch log 13 feet long contains 0.28 standards (the square of 10 divided by the square of 19). Expressed algebraically the formula for determining the contents of a given log by the 19-inch standard rule is

$$V = \frac{D^2}{19^2} \times \frac{L}{13},$$

in which V represents the volume in standards, D the diameter inside the bark at the small end, and L the length of the log.

This log rule is most commonly used in the Adirondack Mountains of New York. It is particularly popular in measuring pulp wood because the rule is based on volume and not on board measure. It is sometimes called the Glens Falls Standard rule. It has been called by some the Dimick rule because it is published in Dimick's Ready Reckoner. This booklet, edited by L. Dimick, may be purchased for 25 cents from Crittenden and Cowles, Glens Falls, N. Y.

Standard measure is commonly translated into board measure by multiplying the volume of a given log in standards by a constant. In the case of the Nineteen-inch Standard rule, it is assumed that one standard is equivalent to 200 board feet, and the number of standards in a log, regardless of its size, is multiplied by 200 in translating from standard to board measure. This procedure is emphatically incorrect, because the contents of logs measured in standards vary as the squares of the diameters, while the contents of logs measured in board feet vary by a totally

different rule (see sections 19-21). When a standard table is converted into board measure by multiplying throughout by a constant, as for example 200, it incorrectly is assumed that the board contents vary as the squares of the diameters of the logs. When logs of different diameters are scaled both in standard measure and board measure, the results are not the same as when the logs are scaled in standard measure and converted into board measure by multiplying by 200. It is true that the average of a very large lot of logs when measured by the two scales will run about 200 feet to the standard (based on Doyle's rule). This is the only way that the converting factor can correctly be used. It should not be used when applied to individual diameters. The table on page 56 shows that, taking logs separately, there are not 5 standards to the thousand, but from 4 to nearly 14 standards to the thousand, according to the diameters of the logs.

34. The New Hampshire Rule (Blodgett Rule). Although usually not recognized as a standard log rule, the Blodgett rule, which has been adopted as the statute rule of New Hampshire, is nothing more nor less than a standard rule based on the same principles as that of the Adirondack market described above. The Blodgett standard, as fully described on page 363, assumes as a unit a log 1 foot long and 16 inches in diameter. The contents in so-called cubic feet (more correctly standards) of a log of any dimensions is found by the following formula:

$$V = \frac{D^2}{16^2} \times L,$$

in which V is the volume in standards, D the diameter in inches, and L the length of the log in feet.

This rule is now being very generally introduced in the spruce region of northern New England for the measurement of long logs which are cut for pulp. The reason for its popularity is because it is a volume rule. In the manufacture of wood pulp

COMPARISON OF 13-FOOT LOGS SCALED IN STANDARDS AND BOARD MEASURE.

(From Report of N. Y. Forest Commission, 1894).

Diameter, Inches.*	Standard Measure.	Number of Logs to a Standard.	Number of Feet, Log Measure.†	Number of Logs per 1000 Feet.	Number of Standards per 1000 Feet.
8	.177	5.6	13	76.9	13.7
9	.224	4.5	20	50.0	11.1
10	.277	3.6	29	34.5	9.6
11	.335	3.0	40	25.0	8.3
12	.399	2.5	52	19.2	7.7
13	.468	2.1	66	15.1	7.2
14	.543	1.8	81	12.3	6.8
15	.623	1.6	98	10.2	6.4
16	.709	1.4	117	8.5	6.1
17	.800	1.2	137	7.3	5.8
18	.897	1.1	159	6.3	5.7
19	1.000	1.0	183	5.5	5.5
20	1.108	.9	208	4.8	5.3
21	1.221	.8	235	4.2	5.2
22	1.341	.7	263	3.8	5.1
23	1.465	.7	293	3.4	5.0
24	1.595	.6	325	3.1	4.9
25	1.731	.6	358	2.8	4.8
26	1.872	.5	393	2.5	4.7
27	2.020	.5	430	2.3	4.6
28	2.172	.5	468	2.1	4.6
29	2.330	.4	508	2.0	4.6
30	2.493	.4	549	1.8	4.5
31	2.662	.4	592	1.7	4.5
32	2.836	.3	637	1.6	4.4
33	3.017	.3	683	1.5	4.4
34	3.202	.3	731	1.4	4.3
35	3.393	.3	781	1.3	4.3
36	3.590	.3	832	1.2	4.3

* At top end of log, inside the bark.

† Doyle's Rule.

the entire log is utilized, there being very little waste. Land-owners are therefore demanding a unit of measure which will take into account the entire contents of the logs. Another reason for the adoption of the New Hampshire rule is the widespread dissatisfaction with the Maine rule as it is now used. The reader is referred to the discussion of the New Hampshire rule in sections 37 and 38.

Just as in the case of the Adirondack standard, lumbermen are accustomed to convert the Blodgett rule into board measure.

The statute states that the ratio of the Blodgett standard to the thousand feet shall be as 100 is to 1000, or 10 feet in every cubic foot. In practice the lumbermen consider that there are 115 Blodgett feet in 1000 board feet when the diameter measurement is taken at the middle of the log and 106 Blodgett feet per 1000 board feet when the measurement is taken at the small end of the log. These are fair average figures and in practice are applicable in converting the scale of a large lot of logs jumped together from one measure to the other. It is not, however, fair to construct a log table for board measure by dividing the values in the Blodgett rule by the constants 106 or 115. Such a log rule for board measure still remains a volume rule, although expressed in board feet. The values in the table are not proportional to the board measure of the log, but to the cubic volume measure.

35. The Cube Rule.—Another standard rule is the so-called Cube rule of the Ohio River. This is based on the hypothesis that a log 18 inches in diameter is the smallest one from which a 12-inch square piece can be cut. To use local phraseology, an 18-inch log will cube once, meaning that for each linear foot there will be one cube. To estimate the contents of a log, square the diameter in inches, multiply by the length in feet, and then divide by the square of 18. Algebraically,

$$V = \frac{D^2}{18^2} \times L,$$

Ordinarily 12 board feet are allowed for one cube.

This rule is known also as the Big Sandy Cube Rule.

36. Other Standard Rules.—The Twenty-two Inch Standard Rule is still used to some extent in New York State and probably elsewhere. The unit is a log 12 feet long and 22 inches in diameter at the small end inside the bark. The rule is used in the same way as the Nineteen-inch Standard rule, and a table may be constructed on the same principle. The 22-inch standard log

FOREST MENSURATION.

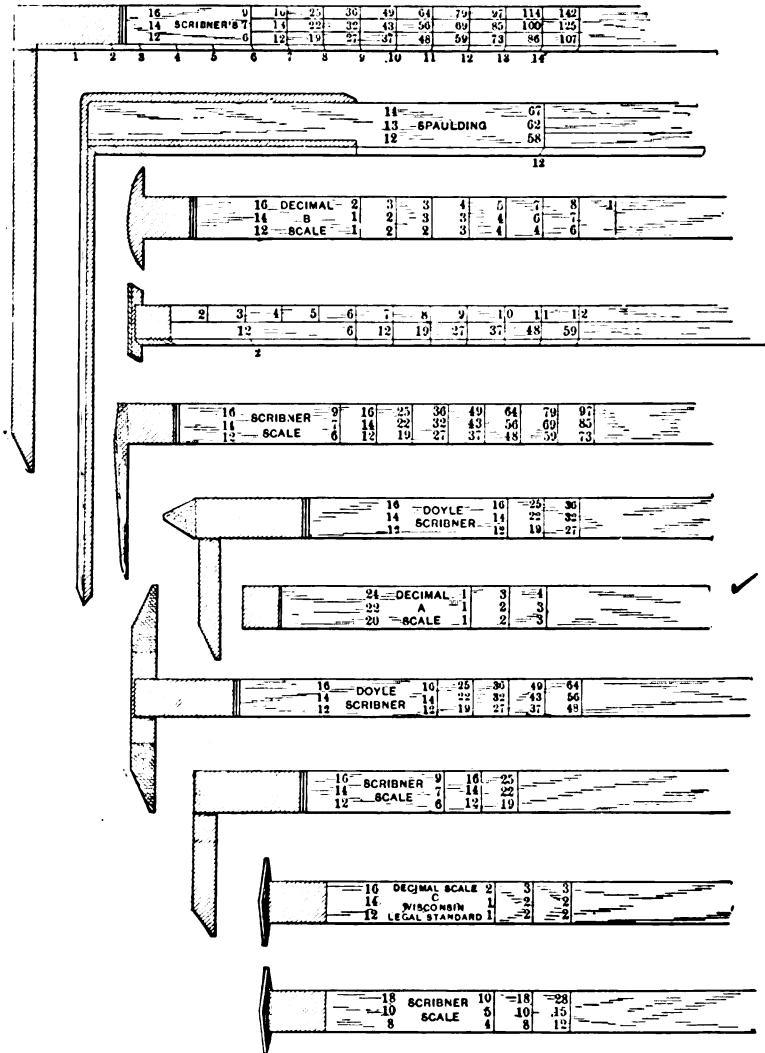

FIG. 1.—Different Forms of Scale Rules

contains 252 board feet (Scribner rule). Common usage gives four standards to the thousand board feet. The Twenty-two Inch Standard rule is sometimes called the Saranac River Standard rule.

The Twenty-four Inch Standard rule is based on a standard log 24 inches in diameter inside the bark at the small end and 12 feet long. The standard log contains 300 feet, board measure, according to the Doyle Rule. In the use of this rule timber is usually sold by the standard or by the 300 feet, instead of by the thousand feet, as commonly; the logs are scaled by the Doyle rule and the total number of feet divided by 300, the unit of sale being a certain sum per standard. To obtain the value of the odd number of feet, the latter are divided by 300 and multiplied by the price per standard.

The Canadian standard rules are based on logs 12 feet instead of 13 feet in length, and 21 and 22 inches, respectively, in diameter. These rules are used in the same way as the American standard rules already described.

CHAPTER V.

METHODS OF SCALING LOGS.

37. Instruments for Scaling Logs.—The measurement of logs to ascertain their contents is called scaling. The instrument used for measuring logs is called a scale stick, scale rule, or log rule. A number of different types are manufactured. The most common type of scale rule consists of a stick, square or flat, which may be placed on the end of a log and shows, by two sets of figures on its face, both the diameter of the log and its contents in board feet. At each inch-mark is indicated the volume in board feet, by a specified rule, of a log of that diameter. Each line of figures represents the results for one length of log, the lengths being indicated at the left-hand end of the stick. It is exactly as if a printed log rule were wrapped about the stick. The flat type of stick is most commonly used throughout the country. These rules are generally made of hickory and tipped with a plain binding of brass or by a head of iron. There are in use a variety of such heads for the measurement of logs of different forms. Fig. 1 shows a number of forms made by the Lufkin Rule Co., Saginaw, Mich. The advantage of a head is that the rule may be placed quickly and accurately on the end of the log. If there is no such guide, inaccuracies are frequent through carelessness in not placing the end of the rule exactly at the edge. This type of rule, however, is applicable only where the log has been peeled. Where logs are scaled with the bark on, the plain rule with no guide-head must be used, or a reduction in the measure made for the thickness of the bark.

Sometimes logs are "nosed"; that is, the sharp edges are rounded off with the axe to prevent splitting ("brooming") of the ends in transportation. In scaling such logs a long guide-head on the scale-stick is needed. Occasionally scale-sticks are made hexagonal instead of flat or square. The old Cary and Parsons scales of Maine were formerly constructed in this way. Where scaling in the woods consists merely in measuring the diameters of the logs, a flat rule graduated in inches and half inches is used. These rules are often made by the scalers themselves, or for them by the camp blacksmith. A common type consists of a flat steel rule 1 inch wide attached to a wooden handle.

Several firms manufacture a caliper scale for the Scribner rule. Calipers are used also where the diameter is measured at the middle or at one-third from the end. The New Hampshire rule requires a measurement at the middle of the log. Therefore a caliper rule is used. The most common form is one in which there is a depression on the inside of each arm, so that the recorded diameter is less than the real diameter. This is the allowance for bark. These calipers are constructed for use with spruce, and an allowance is made on the calipers equivalent to the average thickness of spruce bark at the middle of an average log. The scaler is thus saved the trouble of chipping off the bark or of measuring its thickness. It is, of course, a rough method to assume that on all logs the thickness of bark is the same.

For measuring the lengths of logs a wheel is often used. It consists of ten spokes, each tipped with a spike, mounted on a small hub which is attached to the caliper scale. The spokes are all painted black except one, which is yellow, and this one is weighted with a band of lead, so that it always points downward when at rest. When the wheel is placed on a log, the yellow spoke touches the log first. The construction is such that the tips of the spokes are 6 inches apart. When the wheel is run along a log, each revolution, easily counted by the yellow spoke, measures 5 feet, and as the distance between the spokes is 6 inches,

the length of a log may quickly be determined to within 6 inches. (Fig. 2.)

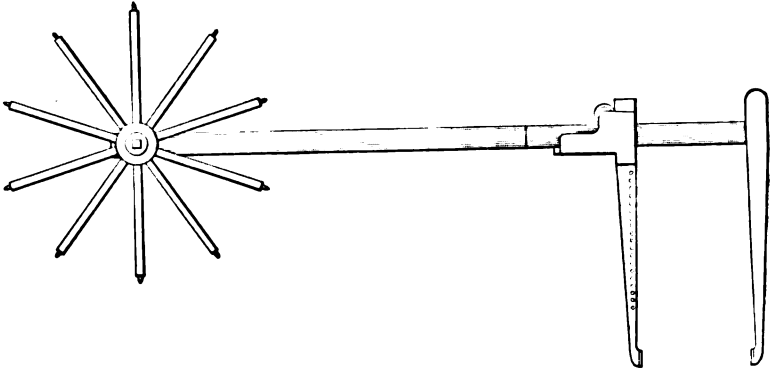

FIG. 2.—Wheel for Measuring Lengths of Logs.

38. Methods of Measuring the Diameters and Lengths.—The methods of scaling logs differ in using different rules and according to local differences in the character of timber, in the market requirements, in the habit of the individual scalers, etc. In regions where the logs are cut into short lengths and piled on skidways for winter hauling, as in the Adirondacks, the scaling is done in the following way: Ordinarily two men constitute the scaling crew. They are provided with a rule for measuring the diameters of the logs, a note-book, tally-sheets or a "scale-paddle" for recording the measurements, a special marking-hammer, and crayons for marking the logs. One scaler measures the diameters of the logs inside the bark at the small end; the other records the results. Only the smallest diameter is recorded, since the log tables are based on length and on diameter at the small end of the log. It is not necessary to measure separately the length of each log, for there are usually only a few standard lengths, as, for example, 10, 12, 13, 14, and 16 feet. The scaler can tell at a glance the correct length. If a log is slightly longer than the standard, the extra length is disregarded. For example,

a log 16.5 feet long is scaled as a 16-foot log. If 18 feet is the next standard length, a log 17.5 feet long is scaled as a 16-foot log. Therefore, a log may be slightly longer than the specified length but never shorter. If a log is shorter than the length of the shortest specification (ordinarily 8 or 10 feet) it is discarded entirely. A great deal of waste is caused by choppers through careless measurement of log lengths.

In measuring the ends of logs, the diameters are rounded to whole inches. If a diameter is nearer 7 than 6 inches, the log is tallied as 7 inches. If the diameter is exactly between two whole inches, as, for example, 9.5 inches, the scaler usually tallies it under the lower inch class, in this case 9. Sometimes scalers endeavor to throw about half of such logs into the inch class below and half into the class above. Very conservative scalers record all diameters falling between two whole inches in the lower inch class, even if it is within one-tenth of an inch of the next class (for example 6.9 inches would be called 6-inches).

When logs are evidently not round, the rule is usually placed at a point on the cross-section where the diameter is about an average between the largest and smallest dimensions. Some scalers always take the smallest diameters, a precaution necessary in measuring veneer logs.

The field records are taken on special forms prepared by the company owning or buying the logs. Often the scalers use a blank-book or wooden scale-paddle in the woods, and then transfer the figures to regular forms at the camp.

There are two methods of recording the measurements. The most common way is to tally the logs by diameter and length, and then afterwards compute the volume in the office. The other way is to record the board contents of each log as shown by the scale-stick.

When a log has been scaled, the end is chalked to prevent its measurement a second time. Logs which are to be discarded receive a special chalk-mark. At this time or later the logs are stamped with the special marking-hammer of the purchaser of

the logs. It is customary in many places to blaze a tree near each skidway, and mark the number of the skidway and number of logs tallied. Thus $\frac{23}{480}$ would mean that there are 460 logs on skidway number 23.

The description of scaling given in the previous pages applies to the northern regions where logs are cut short and where roads are used for hauling. The principles of scaling are practically the same in other sections where short logs are cut. When the logs are loaded on cars in the woods, the scaling is generally done on the cars after loading. Where logs are to be driven, they may be scaled on the bank before rolling into the river, or, where slides are used, at the side of the slide before they are started. Naturally the accuracy of the different scalers varies tremendously. Some guess at the dimensions of many of the logs without measuring them, and even estimate the total run of a pile without bothering to measure any of the logs in it.

In Maine and also in some parts of New Hampshire, spruce is cut in long logs, that is, the entire merchantable part of the tree is taken out in one log. The scaling is sometimes done as the logs are hauled to the skidways or yards, and sometimes at the landing if they are to be driven. If the Maine Log rule is used, the scaler's outfit consists of the ordinary Maine scale-stick, a measuring-pole or tape, marking-hammer, and chalk and note-book. The small end of the log and its length are measured. The results in board feet are read directly from the stick and recorded on special tally-blanks or in a note-book.

The Maine rule gives figures for lengths only up to 30 feet, so that if a log is longer than that, it must be scaled as two logs. Ordinarily the diameter at the small end alone is measured, the scaler estimating the diameter at the middle. Thus if a log is 36 feet long, the small diameter 7 inches, and the diameter at the center estimated at 9 inches, the contents of two 18-foot logs, respectively 9 and 7 inches in diameter, are read from the stick as the contents of the whole log. The scaler guesses at the middle diameter of the log after measuring the top. The increase in size from top to center (called the "rise") may be estimated

very accurately by experienced scalers. Sometimes a scale-stick is used which gives the contents of whole logs over 28 feet long, constructed on the principle that logs 28 to 32 feet long have a rise from tip to center of 1 inch, those 32 to 36 feet long a rise of 2 inches, those 36 to 40 feet long a rise of 3 inches. The rise of logs over 40 feet long is left to the scaler's judgment. The stick thus constructed is called the regular five-line rule.

Deductions for crooks and other defects are made according to the judgment of the scaler. There are no rules, the discounting being entirely a matter of experience. In common practice it is mostly customary to reduce the total scale of a lot of logs by a certain percentage as a factor of safety. This is particularly the case where the quality of logs is extremely poor. For example, the disease of cypress called "peckiness" is so difficult to discover from external signs that a general reduction for safety is necessary.

The growth of the pulp industry in Maine has introduced a new factor in the scaling of spruce. Inasmuch as the whole log is used in making pulp, a solid measure is more appropriate than board measure. For this reason many operators are now using the Blodgett rule. This requires the measurement of the middle diameter of a log instead of the end diameter. The measurement is taken with calipers of the type described before. The length of the log is measured and the middle point located by a wheel. The diameter is taken outside the bark, the calipers being constructed to allow for an average bark width. The contents of the log are read directly from the beam of the caliper. The deduction for defects is made as with the Maine rule.

In scaling long logs by the Doyle rule, the diameter is measured at the middle or the two ends are averaged. Better results are obtained if long logs are measured in short lengths and the diameters taken at the points where the cuts would be made.

39. Methods of Making Discount for Defects.—If all the logs on a skidway were sound and straight the operation of scaling would be largely mechanical and would not require much skill. But many logs are cut and piled which are partly rotten, crooked,

or seamy. They must be entirely discarded or reductions must be made for imperfections when the contents are calculated. Skill is required in deciding what logs should be thrown out. The obviously rotten logs are not piled on the skidway at all. The contractors include many which are doubtful, and which they think may be accepted by the purchaser. The final decision rests with the scalers. There are many logs having center rot or rot only on one side, seamy, shaky, and crooked logs, which contain enough good lumber to pay for the hauling, but cannot be given a scale equivalent to straight sound logs of equal dimensions. When such a log is measured, a deduction is made to compensate for the loss through the imperfection. If the scaler is recording only the diameters and lengths of the logs, discount for defects in a specified log is usually made by reducing the measured diameter sufficiently to cover the loss. Sometimes, chiefly in the South, the allowance for defect is made by reducing the log's length. If the contents of the logs are reduced in the woods, the discount in board feet is made when the log is measured. The experienced scaler who has worked at a saw-mill is able to estimate the loss through certain imperfections merely by inspecting the log. It requires skill and experience to recognize defects and to know how much they affect the quality of the timber. It also requires good judgment to determine how much the dimensions of a defective log should be reduced to scale what can actually be manufactured from it. The best scalers have this experience and judgment. Many, however, make deductions for defects largely by guesswork. The writer has encountered a few rules for special cases, but there is apparently no uniformity in practice among different scalers. This lack of uniformity is unfortunate, and while it is impossible to lay down rules which are universally applicable, it is possible to classify the principal problems met by scalers. It would be entirely practicable for lumbermen to follow a uniform system of handling these problems, making modifications as required in special cases.

Discount for Center Rot.—If a log has a rotten spot at the center, and there is enough good wood to pay for hauling, a dis-

count for the defect is made in the scale. Several incorrect methods for computing this discount are in use. One method requires the subtraction of the diameter of the rotten core from the diameter of the log for the required diameter. Thus if a 12-foot log were 20 inches in diameter, and the rotten core had a diameter of 6 inches, this method would make the new diameter 14 inches. The loss (using the Champlain Rule) would be 122 board feet, which is ridiculous. Another method is to scale the log as sound, compute the contents of a log the size of the core, and subtract this from the scale of the log. In case of the 20-inch log with a 6-inch center rot the loss would be 17 board feet. Another scheme is to add 3 inches to the diameter of the rotten core, square this and deduct from the gross measurement. The result, if the method be applied to the example above, would show a loss of 81 feet. The actual loss, as shown by a diagram, would be 33 board feet. This shows that some of the methods of scaling in practice are thoroughly incorrect.

The writer has for some time considered the possibility of "CULL TABLES" to assist scalers in making discounts for specified sorts of defects in logs. In pursuance of the idea of basing such "CULL TABLES" on diagrams, the writer secured the services of Mr. H. D. Tiemann, of the U. S. Forest Service, to experiment with the construction of the tables. In the first place Mr. Tiemann constructed a series of diagrams representing the cross-sections of logs of different diameters and calculated the actual loss occasioned by center holes of different sizes. In constructing the diagrams, $\frac{1}{4}$ inch was allowed for saw-kerf and 4 inches as the width of the narrowest board. It was assumed that the logs would be sawed so as to yield the greatest possible output. Experiment showed that the most is obtained by "sawing through and through" up to a certain point where the holes are large enough to make "sawing around" necessary. It was recognized also that in sawing through and through there might be a difference whether the log is cut so as to have an inch board from the center or to have the saw pass exactly through the center. In every case the maximum yield was used.

Mr. Tiemann's study established the fact that *in logs of the same length, the loss due to holes of any specified size is practically uniform, regardless of the diameter of the log.* This law is clearly shown in the table below. It happens that for 12-foot logs this loss is almost exactly expressed by the formula

$$\frac{\pi}{5}(D+1)^2, \text{ where } D \text{ is the diameter of the hole.}$$

LOSS BY CENTER-ROT IN TWELVE-FOOT LOGS OF SELECTED DIAMETERS AS SHOWN IN DIAGRAMS.

Diam. of Hole.	12-inch Log. Loss when Sawed		16-inch Log. Loss when Sawed		24-inch Log. Loss when Sawed		36-inch Log. Loss when Sawed		48-inch Log. Loss when Sawed	
	Thro'gh	Around	Thro'gh	Around	Thro'gh	Around	Thro'gh	Around	Thro'gh	Around
Ins.	Board Feet.		Board Feet		Board Feet.		Board Feet.		Board Feet.	
2	6	14	6	12	4	12	2	16		
3	9	14	9	12	9	12	9	26		
4	28	14	13	20	11	12	12	26	11	
6	53	34	29	30	27	32	27	44		
8	69	50	76	52	45	54	47	70	51	
10	112	82	70	92	65	80		
12	132	120	106	132	110	132	108	
16	221	186	173	194	175	
20	314	306	276	306	272	

Note.—The double lines are drawn at the points where the loss is greater by sawing through than by sawing around.

In practice, logs which have holes are apt to have more loss from hidden defects than others. Therefore it is wise to allow a further loss of 5%. This gives the very simple formula of loss in board feet due to center holes:

$$\text{Loss} = \frac{2}{3}(D+1)^2.$$

A table showing the loss in board feet for logs of different sizes and holes of different diameters has been constructed by

this formula, first for 12-foot logs and then for 10-, 13-, 14-, 16-, 18-, and 20-foot logs, and is given on page 71.

This table is applicable to all center defects, such as holes, cup shake, rot, etc., which are four inches or more from the bark. (Fig. 3, *D*, *E*, and *F*.) To apply the table, measure

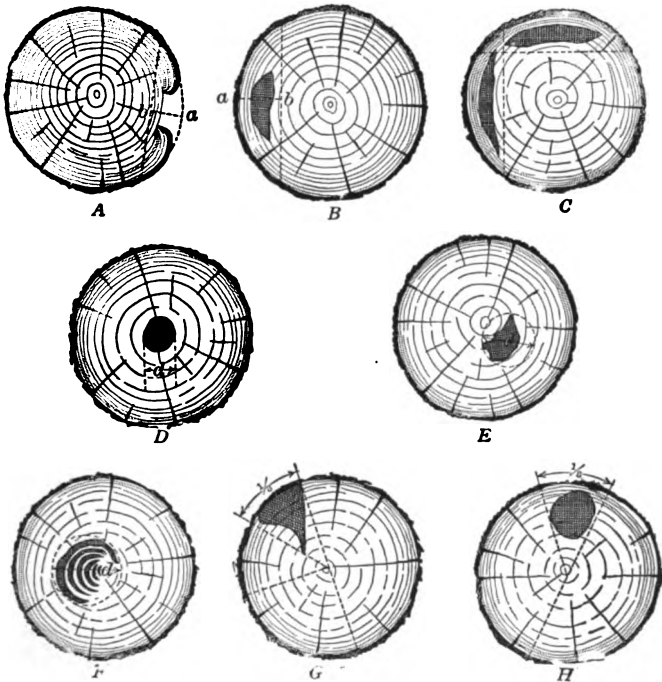

FIG. 3.—Methods for Discounting the Scale for Defects.

the longest diameter of the defect, find the loss in board feet from the cull table, and deduct from the gross scale of the log. If the defect runs through the log, or if it appears only at the large end, measure the defect at the large end, otherwise at the small end. The table should be used only with short logs.

Some may naturally ask how one is to determine the length of a hole if it appears at only one end. It is assumed that, if a defect appears at one end, there will be a loss to the center board

throughout the length. If short pieces can be utilized, that is the gain of the millman, and the fact is an element of conservatism in the rule. The same principle holds good for the succeeding cull rules.

Discount for Defects near the Edge of Logs.—Under this head may be included rot, splits due to careless felling, superficial shake due to fire scars, sun scald, frost, or any other defects which require the removal of a wide slab, as shown in Fig. 3, *A*, *B*, and *C*. Cull Table *B* has been constructed, by the use of diagrams, to show the loss by cutting slabs of different widths from logs of different diameters and lengths. The scaler measures the width of the slab which would obviously have to be cut off, finds in the table the loss in board feet, and deducts this from the gross scale of the log. If the defect runs through the log, following the grain, and does not extend deeper at the large than at the small end, the measurement is taken at the top. If the defect appears only at the large end, or extends relatively nearer the center than at the small end, the scaler must estimate the width of the slab, at the small end, which would have to be taken off.

Cull Table *C* is designed to meet the case of defects on the side of a log, which the sawyer eliminates by cutting around them, rather than by taking off a wide slab. These are narrow defects running rather deep into the log, such as are indicated in Fig. 3, *G* and *H*. The loss in sawing around such a defect was found by Mr. Tiemann to be equivalent to removing a wedge-shaped piece, a sector, fully enclosing the defect, though this principle does not exactly indicate the sawyer's method of sawing the log. On this principle Cull Table *C* was constructed, by diagrams, to show the loss by cutting around sectors of different sizes from logs of different diameters and lengths. To use the table, estimate whether the defective spot is entirely included within one-sixteenth, one-eighth, etc., as represented by a fraction of the circumference of the end of the log, then find the loss from the table and deduct from the gross scale. Just as in the case of cutting a wide slab, the scaler must estimate, with reference to the small end, the portion of the log wasted.

CULL TABLE A.
LOSS BY DEFECTS OF DIFFERENT DIAMETERS NEAR THE CENTER
OF LOGS.
 (Good for defects more than 4 inches from the bark.)

Diameter of Defect.	Length of Logs in Feet.						
	10	12	13	14	16	18	20
Inches.	Board Feet.						
2	5	6	6.5	7	8	9	10
3	9	11	12	13	15	16.5	18
4	14	17	18	20	23	25.5	28
5	20	24	26	28	32	36	40
6	27.5	33	36	38.5	44	49.5	55
7	36	43	47	50	57	65	72
8	45	54	58.5	63	72	81	90
9	56	67	74	78	89	100	112
10	67	81	87	93	107	120	133
11	80	96	104	112	128	144	160
12	94	113	122	132	151	169.5	188
13	109	131	142	153	175	196.5	218
14	125	150	162.5	175	200	225	250
15	142	171	184	218	226	255	283

CULL TABLE B.
LOSS BY CUTTING SLABS FROM ONE SIDE OF TEN-FOOT LOGS.

Width of Slab, Inches.	Diameter of Log in Inches.										
	6	8	10	12	14	16	18	20	22	24	26
	Board Feet.										
1	0	0	1	1	2	2	3	3	3	4	4
2	3	4	5	5	6	7	8	8	8	10	10
3	7	8	9	10	11	13	14	15	15	16	17
4	14	15	17	19	20	22	23	25	26	28
5	22	24	26	28	30	33	35	37	39
6	33	35	38	41	43	46	49	52
7	45	49	52	55	59	62	65
8	60	65	68	73	76	80
9	77	82	86	91	96
10	97	102	107	112
11	119	124	129
12	141	148
13	167

FOREST MENSURATION

CULL TABLE B.

LOSS BY CUTTING SLABS FROM ONE SIDE OF TWELVE-FOOT LOGS.

Width of Slab, Inches.	Diameter of Log in Inches.										
	6	8	10	12	14	16	18	20	22	24	26
	Board Feet.										
1	0	1	1	2	2	3	3	4	4	5	5
2	4	5	6	7	7	8	9	10	11	11	12
3	9	10	11	13	14	15	16	18	19	20	21
4	17	19	21	23	24	26	28	30	31	33
5	27	29	32	34	37	39	42	44	47
6	39	43	46	49	52	56	59	62
7	55	59	63	67	71	75	79
8	73	78	82	87	92	97
9	93	98	104	110	115
10	117	123	129	135
11	142	149	155
12	170	178
13	200

CULL TABLE B.

LOSS BY CUTTING SLABS FROM ONE SIDE OF FOURTEEN-FOOT LOGS.

Width of Slab, Inches.	Diameter of Log in Inches.										
	6	8	10	12	14	16	18	20	22	24	26
	Board Feet.										
1	0	1	1	2	2	3	4	4	5	6	6
2	4	5	6	7	8	9	10	11	12	13	14
3	10	12	13	15	16	18	19	20	22	23	25
4	19	22	24	26	28	30	32	34	36	39
5	31	34	37	40	43	46	48	51	54
6	46	50	53	57	61	65	68	72
7	64	68	73	78	82	87	92
8	85	91	96	102	107	113
9	108	114	121	128	134
10	136	143	150	157
11	166	173	181
12	197	207
13	234

CULL TABLE B.
LOSS BY CUTTING SLABS FROM ONE SIDE OF SIXTEEN-FOOT LOGS.

Width of Slab, Inches.	Diameter of Log in Inches.										
	6	8	10	12	14	16	18	20	22	24	26
	Board Feet.										
1	0	1	1	2	3	3	4	5	5	6	7
2	5	6	7	9	10	11	12	13	14	15	16
3	11	13	15	17	18	20	21	23	25	26	28
4	22	25	27	30	32	35	37	39	41	44
5	35	39	42	45	49	52	55	59	62
6	52	57	61	65	69	74	78	83
7	73	78	83	89	94	99	105
8	97	103	109	116	122	128
9	123	131	138	146	153
10	155	163	171	179
11	189	198	207
12	226	237
13	268

Discount for Crooks.—Usually logs are supposed to be straight, and the scaler does not make any discount for crooks when he measures the logs. When logs are piled on skidways, it is obviously impossible to take crooks into consideration. Often, however, a small percentage is deducted from the total scale to allow for this imperfection. To make allowance for the loss by crooks in a specified log, the scaler sights over the surface and calculates how much the small end must be reduced to circumscribe the square piece which really can be cut from the log.

Discount for Wormy or Rotten Sap.—The diameter measurement is taken inside the sap, that is, the heart-wood alone is scaled.

Discount for Seams and Shakes.—Seamy and shaky logs are usually culled altogether. Sometimes in a tree with straight grain, a seam causes only the loss of one plank in the center. This loss may be calculated by the rule: Multiply the thickness of the plank to be discarded by the diameter of the log, multiply by the length and divide by 12. Usually the grain of the log is not straight and it has to be discarded altogether.

CULL TABLE C.

LOSS FROM DEFECTS CONTAINED IN SECTORS REPRESENTING FRACTIONS OF LOGS.

Length of Log, Feet.	Part of Circle Re-moved.	Diameter of Log in Inches.										
		6	8	10	12	14	16	18	20	22	24	26
		Board Feet.										
10	$\frac{1}{16}$	2	3	5	6	8	11	14	17	20	25	30
	$\frac{1}{8}$	4	6	8	11	14	18	22	28	33	41	49
	$\frac{3}{16}$	7	10	15	20	25	32	40	49	61	75	90
	$\frac{1}{4}$	7	14	22	30	39	49	62	77	94	114	134
	$\frac{5}{16}$	7	14	22	33	45	60	77	97	119	141	167
12	$\frac{1}{16}$	2	4	6	8	10	13	17	20	25	30	36
	$\frac{1}{8}$	5	7	10	13	17	21	27	33	40	49	59
	$\frac{3}{16}$	9	13	18	24	30	39	48	59	73	90	108
	$\frac{1}{4}$	9	17	27	36	47	59	75	93	113	136	160
	$\frac{5}{16}$	9	17	27	39	55	73	93	117	142	170	200
14	$\frac{1}{16}$	2	4	6	9	12	15	20	23	29	34	42
	$\frac{1}{8}$	6	8	12	15	19	25	31	39	47	57	69
	$\frac{3}{16}$	10	15	20	27	35	45	56	69	85	105	126
	$\frac{1}{4}$	10	19	31	41	54	69	87	108	132	159	187
	$\frac{5}{16}$	10	19	31	46	64	85	108	136	166	197	234
16	$\frac{1}{16}$	3	5	7	10	13	17	23	27	33	39	48
	$\frac{1}{8}$	7	9	13	17	22	28	35	44	53	65	79
	$\frac{3}{16}$	11	17	23	31	40	51	64	79	97	120	144
	$\frac{1}{4}$	11	22	35	47	62	79	99	123	151	181	213
	$\frac{5}{16}$	11	22	35	52	73	97	123	155	189	226	268

Shaky logs are usually valueless. If the shake is confined to the center, the cull rule for center-rot may be used.

40. Rules for Scaling Used on the Forest Reserves.—The following rules * have been issued to the Federal forest officers to govern the scaling in timber sales on the forest reserves:

All timber must be scaled by a forest officer before it is removed from the tract or from the points where it is agreed that scaling shall be done. Each stick of sawlogs, timbers, poles, and lagging must be scaled separately. Rough averaging of diameters or

* From The Use of the National Forest Reserves, U. S. Dept. of Agriculture, Washington, D. C., 1905.

lengths is not allowed. The Scribner rules will be used in all cases.

Ties may be actually scaled, or reckoned as follows:

Eight-foot ties, standard face, $33\frac{1}{2}$ feet B. M., each; 6-foot ties, standard face, 25 feet B. M., each.

Shake and shingle-bolt material is measured by the cord.

Squared timbers are scaled by their actual contents in board feet with no allowance for saw-kerf. Thus, an 8×12 -inch 16-foot stick contains 128 feet B. M.

Unsound or crooked logs will be scaled down to represent the actual contents of merchantable material. All partially unsound but merchantable stuff must be scaled, whether removed or not. In ground-rotten timber, butts which, though unsound at heart, contain good lumber toward the outside, are frequently left in the woods. Where such material will pay for sawing, the forest officer will scale it at what he considers its true value and include it in the amount purchased.

Logs which are not round will be scaled on the average diameter; flats and lagging on the widest diameter.

In the absence of a log rule, or where the position of logs in the pile makes its use difficult, the diameters and lengths may be tallied and the contents figured from a scale table later.

When possible, the purchaser will be required to mark top ends of logs to avoid question when they are scaled in the pile. The forest officer should insist on having one end of piles or skidways even, so that ends of logs may be easily reached. When the lengths of piled logs are hard to get, two men should work together.

When scaled, each stick of sawlogs, timbers, ties, lagging, posts, poles, or piles must be stamped with the United States mark on at least one end, and on both when possible. Cord material, such as wood or bolts, must be stamped at both top and bottom of piles, and at least 12 pieces in each cord must be stamped.

All scaling is inside of bark.

CHAPTER VI.

DETERMINATION OF THE CONTENTS OF LOGS IN CUBIC FEET.

41. Use of the Cubic Foot in America.—The cubic foot is already used extensively in forestry in the United States. Many of the most useful tables of contents of standing trees, of growth, and of yield, have been obtained by the use of the cubic foot. Although most figures of volume are finally expressed in board feet or other unit common in commerce to have practical value, the cubic foot is often the basis for these results.

Board measure, cord measure, and standard measure are useful only in buying and selling wood and timber. These units can never be used satisfactorily in scientific work where the exact contents of logs and trees are required. The uses of the cubic foot in preparing volume tables for standing trees in cords, board feet, and standards, and in determining the laws of growth of trees under different circumstances are explained in later chapters of the book.

The cubic foot is but seldom used in this country for buying and selling round logs. It is, however, used with high-priced imported woods, occasionally with hickory and oak, and with squared timber. The cubic foot will unquestionably be used more and more, as the value of timber increases, and eventually in large measure replace the present rough unit, the board foot. The American forester must, therefore, be familiar with the principles and methods of determining the cubic contents of logs and trees.

42. The Measurement of Logs to Determine their Cubic Contents.—All the methods of cubing logs require the measurement of the diameter at one or more points and the measurement of the length. Ordinarily the diameter measurements are taken with calipers. Formerly in India and in Europe the circumference was measured with a tape. In this country a tape is only used when calipers cannot be obtained, and in work with the trees of the Pacific Coast which are too large for ordinary calipers. A rule is sometimes used where ends of logs are measured inside the bark, as when a study of growth is being made.

Generally the measurements for volume are taken in the following way: Two measurements are taken with the calipers, one

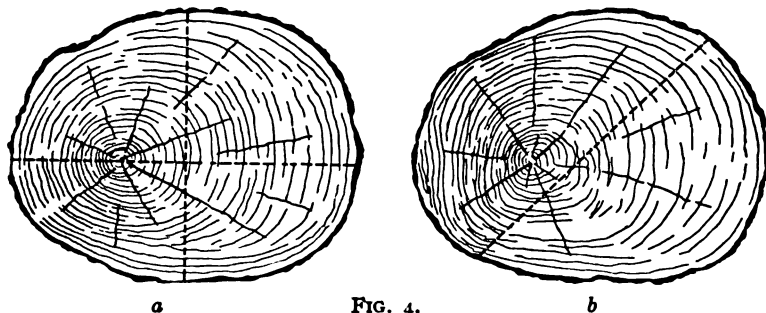

FIG. 4.

giving the greatest and one the smallest diameter. (Fig. 4a.) The average is considered the average diameter of the log at the point measured. If the log appears to be perfectly round, only one measurement is taken. Some attempt to measure one average diameter, even when the log is not round. (Fig. 4b.) Sometimes the log is in such a position that it is difficult to measure accurately the longest and shortest diameters, as when it is lying on a flat side or is sunken in a depression. In such cases the log must be moved or rolled over, if an accurate measurement is to be taken.

If the measurement of diameter inside the bark is sought, the bark may be chipped off or its average width may be determined by

separate measurements and deducted from the diameter outside the bark. Sometimes the diameter outside the bark is desired at a point where the bark is torn away altogether or in part. Then the diameter inside the bark is measured and the average width of bark added, the latter being determined from a neighboring part of the log. Where volume measurements alone are sought, the common practice is to measure the diameter outside the bark, and to determine the inside measurements by deducting the bark width. This method is not so accurate as measuring first inside the bark and adding the bark width. The reason for this is that there are apt to be irregularities of bark which make the measurements of diameter too large, or pieces are broken off and the diameter is too small. This is particularly true with trees with soft scaly bark like the yellow pines. With hardwoods the common method of measuring outside the bark is accurate enough for most purposes.

In determining the average thickness of bark, several measurements should always be taken at different sides of the log, unless the bark is thin and obviously uniform in thickness on the entire circumference. Where the bark is deeply cut, like that of an old pine, each measurement of width should show the thickness between the wood and a line tangent to the log, as the arm of a caliper fitted to the log at that point.

Sometimes there is a swelling due to a knot or other cause at the point where it is desired to take the measurement of diameter. In this case the calipers must be placed just above or below the swelling, or measurements may be taken both just above and below and the average called the correct diameter.

Many inaccuracies arise from the careless use of calipers. They should always be placed at right angles to the log. Inasmuch as the sliding arm of the calipers when moved bends toward the stationary arm, as explained on page 81, care must be taken that it rest tightly against the log and is at right angles to the graduated beam when the reading is taken. Whenever possible, the calipers should be placed so that the beam touches the log.

The measurement should not be taken with the tips of the arms, except in extreme cases, because the measurer is apt not to have the sliding arm brought to a perpendicular position with the beam, and because any inaccuracies of the calipers due to warping or wear are greater at the tip than near the base of the arms. The forester should continually test his calipers to guarantee their accuracy.

In all scientific work diameter measurements are taken in inches and tenths. Foresters are sometimes tempted to round the measurements to half or to whole inches, especially when a large number of logs are being measured. If the cubic foot were used in commerce, the diameter measurements would probably be rounded to the half or whole inch, as is the case where logs are scaled in board measure. At present in this country the measurements of cubic volume are chiefly for scientific purposes, as in the preparation of volume tables, the study of growth, etc., and require diameter measurements to tenths of inches. It is frequently asserted that there are apt to be inaccuracies due to irregularities of the bark, and that in consequence it is inconsistent to take such fine measurements. It is true that there are chances for errors in measuring logs with rough or ragged bark, but this is no reason for deliberately adding to the errors by a rough method of taking the readings from the calipers. Moreover, the rounding of diameter measurements to half or whole inches leads invariably to carelessness on the part of the measurer, who may soon estimate certain diameters without using his calipers, or in other measurements give figures which are estimates rather than true readings from the instruments.

43. Measuring Instruments.—In work on very large logs like redwood logs, circumferences are taken with tapes. A special tape is made for such work, which shows not only the circumference in inches or in feet, but also the diameter corresponding to every circumference. The readings, therefore, may be recorded as diameters, thus avoiding the laborious work of afterwards calculating the diameters from circumference readings.

The end of the tape is provided with a pin which may be inserted in the bark, enabling one person without assistance to measure a large log or tree. (Fig. 5.)

Usually the tape gives a larger result than calipers, because every swelling or abnormal protuberance of bark is included in the tape measurement. It is impossible to bring the tape close against the trunk at all points. Care should, therefore, be taken in using the tape to avoid irregularities on the log which may affect the measurements.

Where the diameters of the ends of the logs are measured, a rule may be used. This is often done in taking full tree



FIG. 5.—Tape for Measuring Girths and Diameters.

analyses. The diameters inside the bark are measured with the rule on the smooth cross-cut, and the outside dimensions obtained by adding the bark width. For these measurements the cross-cut must be made at right angles to the axis of the log, otherwise the figures will be too large.

A number of different forms of calipers are made. American foresters generally use the type of calipers developed by the Forest Service, U. S. Department of Agriculture. This form is extremely simple, and has been found to be light, strong, and durable, as well as very accurate, the qualifications necessary for a satisfactory instrument. These calipers consist of a beam

having scales on both sides graduated in inches and tenths. This beam is provided at one end with an arm held in place by a bolt and nut, which permit it to be detached for convenience of transportation. The beam is provided with a sliding arm fitted loosely so as to slide easily over it, but constructed so that when pressure is applied to its inner edge, it swings into position in which it is at a right angle to the beam. For use in eastern forests the most convenient caliper has a beam measuring 36 inches and arms one half that length. In forests where trees over 3 feet in diameter occur,

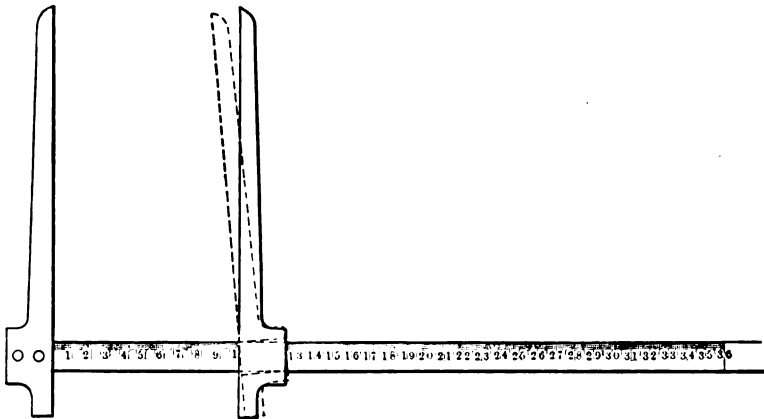

FIG. 6.—American Type of Calipers.

calipers having a beam measuring 50 inches and proportionately long arms are used. The 36-inch calipers weigh 1.9 pounds.

The upper and lower edges of the opening in the sliding arm are lined with metal to prevent wear. The metal strip lining the upper edge is movable at one end, being held in place by a screw (*A* in Fig. 7). This device enables the perfect adjustment of the arm with reference to the beam of the calipers.

The chief disadvantage of the American type is that the space for the beam in the sliding arm is made so narrow that the

latter does not run smoothly or it actually sticks when the beam swells, as often occurs if used in the rain. The same thing happens if the beam becomes slightly coated with pitch, which cannot be avoided when working with pine logs; and again the sliding arm is apt to be clogged by damp snow and seriously interfere with winter work. This disadvantage is obviated in the calipers used in Germany, described below. The German calipers are, however, heavier and for most work in this country less convenient than the American type. This form of calipers is manufactured

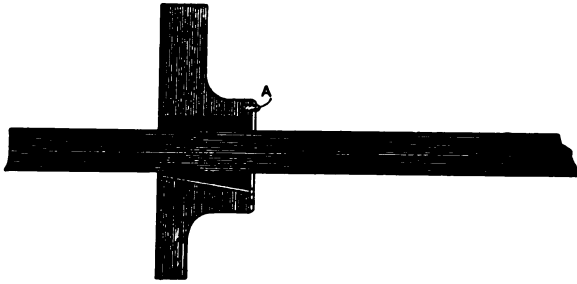

FIG. 7.

by Keuffel & Esser Co., No. 127 Fulton Street, New York City, listed at \$4.50 each.

The calipers used in ordinary forest work in Austria are very similar to the American type just described. The device for adjusting the sliding arm differs only in the position of the retaining-screw. The graduations on the beam are marked in depressions, about an inch wide, in order to protect the marks from the wear of the sliding arm. As ordinarily constructed, the calipers are heavier than those made in this country and have the disadvantage of not taking down.

A number of different kinds of calipers are used in practice in Germany. Simple calipers like the Austrian type above described are used by many foresters. A common form is that made by Staudinger & Co., in Giessen, which has a special con-

struction designed to obviate the difficulty caused by the swelling and consequent sticking of the movable arm. In these calipers the measuring-beam is beveled on the edges so that the cross-section is a regular trapezium.

Fig. 8 shows a section of the movable arm *AA*, including a cross-section of the measuring-beam *M*. The construction is such that at the points *a*, *a'*, and *a''* the measuring-beam fits closely to the sliding arm, but does not come in contact with it at any other points. The sliding arm is further fitted with a metal wedge shown in cross-section as *N*. This wedge is held in place by the screw *o*, and whenever the screw turns is moved toward or away from the measuring-beam. The screw *o* is turned by means of a key, which is provided with

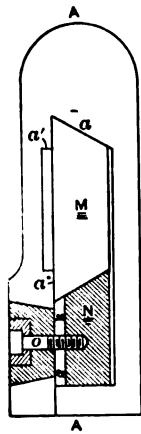

FIG. 8.

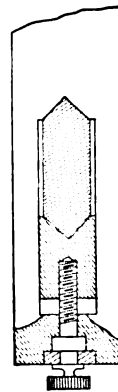

FIG. 9.

two points made to fit the shallow holes in the head of the screw. By loosening or tightening the wedge the sliding arm may be adjusted to suit the condition of the beam. If it is swollen by moisture or coated with pitch, the wedge may be loosened so that the arm will move with ease.

The disadvantage of the calipers is that there is a separate

key, which is easily lost. The construction being less simple than in the forms described above, the weight is necessarily greater. Fig. 9 shows another adjusting arrangement, sometimes found on the sliding arm of German calipers.

A number of folding calipers are constructed for convenience in packing and in carrying to and from work. The author has never seen any folding calipers which were serviceable for practical woods work. They are not so strong as the regular forms, and with use they soon become inaccurate. A caliper which may be taken down like that first described has every advantage of the folding caliper except that it cannot be readily taken apart for transportation to and from daily work. This last advantage is too insignificant to require any sacrifice in the strength and durability of the instrument.

Every European text-book on Forest Mensuration contains descriptions of calipers constructed on other principles, as, for instance, like a carpenter's caliper-gauge. The author has never found any such calipers in extensive practical use even in Europe.

The length of logs is usually taken with a tape graduated in feet and tenths. The length is taken along the surface of the log. If the log is considered a frustum of a cone or paraboloid, this represents the slant height and not the true length of the axis. The error is, however, very minute and may be disregarded. On an average this amounts to only 0.1%, as has been proven by European experiment. It was explained on page 63 that in scaling logs for board feet the length is usually rounded to feet and always to the foot below the actual measure, as, for example, 16 feet, if the actual measure is 16.7 feet. In all scientific work with the cubic foot, the measurements are rounded to tenths of feet or to inches, preferably the former.

For general work of forest measurements a steel tape, measuring 50 feet, is the most satisfactory. It is convenient in size and weight, and is more durable than any other form of tape. A

metallic tape, that is, the cloth tape which has several strands of copper wire running through it, is satisfactory in every respect, except that it frays after a short time when used in the woods. A steel tape will last several years in constant use, provided it is not allowed to rust. After using a steel tape in wet woods, it should always be wiped and oiled.

A number of different forms of steel tape are constructed. The best type has a band $\frac{3}{8}$ inch wide, and costs \$6.50. A cheaper tape with a band $\frac{1}{4}$ inch wide costing \$4.45 answers every purpose, but will not stand as rough wear as the more expensive form. With careful treatment the smaller tape should satisfy the requirements of most foresters. Metallic tapes cost \$2.75. Cloth tapes are impractical for ordinary rough work in the woods. Tapes may be purchased from any dealer in surveying instruments.

44. Principles Underlying the Determination of the Cubic Contents of Logs and Trees.—For many years European foresters have endeavored to discover a mathematical formula by which the cubic contents of logs may accurately be calculated from a few measurements. Great difficulty has been encountered, because the forms of different logs differ so much under different conditions. The form of a specified log depends on its relative growth in diameter at different points. The growth in diameter at different parts of logs varies widely, and in consequence their forms are not uniform.

If the diameter growth on the trunk at certain distances above the ground were always the same for a given species, the form of the trunks of all trees of that species would be constant. But the form of a tree changes from decade to decade, different individuals nearly always differ in form, and logs from different parts of the same tree have different forms. At first sight the surface lines of a log appear to be perfectly straight, as on the section of a cone. Experiment has shown that on most logs the longitudinal surface lines are slightly convex, as on the section of a paraboloid. Sometimes, however, they are slightly concave, in which case

the log approaches the form of a Neilian paraboloid or neiloid. Usually the form of the log is between that of a cone and a paraboloid.

A number of formulæ have been devised which enable the cubing of logs with almost perfect accuracy, the error amounting to less than one percent. The most accurate formulæ, however, require for their use too many different measurements on the logs, or they involve too many calculations, to be of use in practical work. In ordinary work in the woods extremely simple formulæ are used, which are accurate enough for commercial purposes, although they are subject to an error in individual cases of 2 to 4 per cent.

45. Fundamental Formulæ.—It is customary to assume that logs and other parts of felled trees have the form of some known geometric body, as the frustrum of a cone or paraboloid, and to cube them by formulæ applying to these bodies. The methods will be clearer if prefaced by a statement of the most important formulæ for cubing a cylinder, paraboloid, cone, and neiloid. These formulæ are as follows:

FORMULAE FOR DETERMINING THE VOLUME OF A CYLINDER, CONE,
PARABOLOID, AND NEILOID.

The Cylinder.

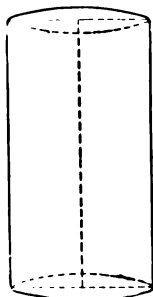

FIG. 10.

Let V = volume of the cylinder;

H = altitude of the cylinder;

R = radius of the base;

D = diameter of the base;

B = area of the base;

$$1. V = \pi R^2 \cdot H;$$

$$2. V = \frac{\pi D^2}{4} \cdot H;$$

$$3. V = B \cdot H.$$

The Full Cone.

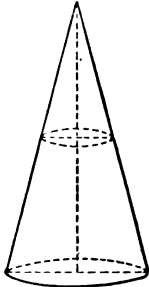

FIG. 11.

Let V = volume of the cone;
 H = altitude of the cone;
 R = radius of the base;
 D = diameter of the base;
 B = area of the base;
 $D_{\frac{1}{3}}$ = diameter at $\frac{1}{3}H$;
 $B_{\frac{1}{3}}$ = area of cross-section at $\frac{1}{3}H$;
 $B_{\frac{2}{3}}$ = area of cross-section at $\frac{2}{3}H$;

$$1. V = \frac{\pi R^2 \cdot H}{3};$$

$$2. V = \frac{\pi D^2 \cdot H}{12};$$

$$3. V = \frac{B \cdot H}{3};$$

$$4. V = \frac{\pi}{3} \cdot D_{\frac{1}{3}} \cdot H;$$

$$5. V = \frac{4}{3} \cdot B_{\frac{1}{3}} \cdot H;$$

$$6. V = (B + 4B_{\frac{1}{3}}) \frac{H}{6};$$

$$7. V = 0.75 \cdot B_{\frac{1}{3}} \cdot H;$$

$$8. V = B_{\frac{1}{3}} \cdot H + \frac{B \cdot H}{12}.$$

Frustum of a Cone.

Let V = volume of the frustum;
 h = altitude;
 R = radius of the lower base;
 D = diameter of the lower base;
 B = area of the lower base;
 r = radius of the upper base;
 d = diameter of the upper base;
 b = area of the upper base;
 $D_{\frac{1}{3}}$ = diameter at $\frac{1}{3}h$;
 $B_{\frac{1}{3}}$ = area of cross-section at $\frac{1}{3}h$;
 $B_{\frac{2}{3}}$ = area of cross-section at $\frac{2}{3}h$;

FOREST MENSURATION.

$$1. V = \frac{\pi}{3}(R^2 + r^2 + R \cdot r)h$$

$$2. V = \frac{\pi}{12}(D^2 + d^2 + D \cdot d)h;$$

$$3. V = (B + b + \sqrt{B \cdot b})\frac{h}{3};$$

$$4. V = (B + 4B_{\frac{1}{2}} + b)\frac{h}{6};$$

$$5. V = (3B_{\frac{1}{2}} + b)\frac{h}{4}.$$

The Paraboloid. Let V = volume of the paraboloid;

H = altitude of the paraboloid;

R = radius of the base;

D = diameter of the base;

B = area of the base;

$D_{\frac{1}{2}}$ = diameter at $\frac{1}{2}H$;

$B_{\frac{1}{2}}$ = area of cross-section at $\frac{1}{2}H$;

$B_{\frac{1}{4}}$ = area of cross-section at $\frac{1}{4}H$.

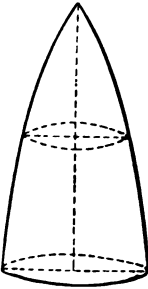

FIG. 12.

$$1. V = \frac{\pi R^2 \cdot H}{2};$$

$$2. V = \frac{\pi D^2 \cdot H}{4} \cdot \frac{H}{2} = \frac{\pi D^2 \cdot H}{8};$$

$$3. V = \frac{B \cdot H}{2};$$

$$4. V = B_{\frac{1}{2}} \cdot H;$$

$$5. V = 0.75 \cdot B_{\frac{1}{2}} \cdot H;$$

$$6. V = (B + 4B_{\frac{1}{2}})\frac{H}{6}.$$

Frustum of a Paraboloid.

Let V = volume of the frustum;

h = altitude of the frustum;

R = radius of the lower base;

D = diameter of the lower base;

B = area of the lower base;

- r = radius of the upper base;
 d = diameter of the upper base;
 b = area of the upper base;
 $D_{\frac{1}{2}}$ = diameter of the cross-section at $\frac{1}{2}h$;
 $B_{\frac{1}{2}}$ = area of the cross-section at $\frac{1}{2}h$;
 $B_{\frac{1}{3}}$ = area of the cross-section at $\frac{1}{3}h$.

$$1. V = (\pi R^2 + \pi r^2) \frac{h}{2};$$

$$2. V = \pi(D^2 + d^2) \frac{h}{8};$$

$$3. V = \frac{B+b}{2} h = (B+b) \frac{h}{2};$$

$$4. V = B_{\frac{1}{2}} \cdot h;$$

$$5. V = (B + 4B_{\frac{1}{2}} + b) \frac{h}{6};$$

$$6. V = (3B_{\frac{1}{2}} + b) \frac{h}{4}.$$

The Neilian Paraboloid or Neiloid.

- Let V = volume of the Neilian paraboloid;
 H = altitude of the Neilian paraboloid;
 R = radius of the base;
 D = diameter of the base;
 B = area of the base;
 $B_{\frac{1}{2}}$ = area of the cross section at $\frac{1}{2}H$.

$$1. V = \frac{\pi R^2 H}{4};$$

$$2. V = \frac{\pi D^2 H}{16};$$

$$3. V = \frac{BH}{4};$$

$$4. V = 2B_{\frac{1}{2}}H;$$

$$5. V = (B + 4B_{\frac{1}{2}}) \frac{H}{6}.$$

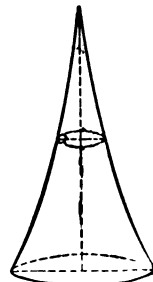

FIG. 13.

Frustrum of a Neilian Paraboloid or Neiloid.

Let V = volume of the frustum;
 H = altitude of the frustum;
 R = radius of the lower base;
 r = radius of the upper base;
 B = area of the lower base;
 b = area of the upper base;
 B_1 = area of the cross-section at $\frac{1}{2}h$.

$$V = \frac{\pi h}{4} (R^2 + \sqrt[3]{R^2 r^2} + \sqrt[3]{R^2 r^2} + r^2);$$

$$V = (B + 4B_1 + b) \frac{h}{6}.$$

46. Determination of Sectional Areas.—Most formulæ for determining the cubic contents of logs are based on the length and the area of one or more cross-sections. Ordinarily the area of a cross-section is considered equivalent to that of a circle whose diameter is the average diameter of the cross-section. The area is computed by the formula, $B = \frac{\pi D^2}{4}$, in which B is the area, and D the diameter of the cross-section. Usually the cross-sections of logs are not perfect circles; but if two or more diameters are measured and averaged, the area of a circle having as a diameter this average will be found to be very close to the real area of the cross-section. If the circumference were taken, the area would be determined by the formula, $B = \frac{C^2}{4\pi}$, in which B is the area and C the circumference of the cross-section. This last method would not be so accurate as that of using an average diameter unless the cross-section were a perfect circle. If the cross-section were not a circle, the result would be too large because with a given perimeter the circle has the largest area of any plane surface. Moreover the irregularities of bark, tend also to give too great a result. Tables are constructed which show the areas of circles corresponding to different diameters, so that no special computations are necessary. Such a table of areas of circles is given in the Appendix.

If a cross-section is elliptical, its area may be accurately determined by the formula for an ellipse, namely, $B = 0.7854D \cdot d$, in which B is the area, D and d the largest and smallest diameters. In practice, however, this method is seldom used.

47. Methods of Determining the Volume of Logs by the Measurement of the End Diameters and the Length (Smalian's method). The diameters of the two ends and the length of the log are measured and the volume calculated by the formula

$$V = \frac{B+b}{2}h \quad \text{or} \quad (B+b)\frac{h}{2},$$

in which V is the volume of the log, B and b are the areas corresponding to the diameters of the two ends, and h is the length.

Example.—A log is 12 feet long and the diameters at the ends are 16 and 18 inches. The areas corresponding to the end diameters are sought in a table of areas of circles and used in the formula, as follows:

$$V = \frac{1.396 + 1.767}{2} + 12 = 18.97 \text{ cubic feet.}$$

By reference to page 89 it will be seen that this is formula No. 3 for cubing the frustum of a paraboloid. It is therefore absolutely correct if the log has the form of a truncated paraboloid. Although nearly every log varies somewhat from this form the results are exceedingly satisfactory, especially for short lengths of logs. The formula may be used for practically any investigations in this country. It is the formula most commonly used by the U. S. Forest Service.

The possible disadvantages of the formula are, first, that on a butt log there is usually a flare at the lower end due to the swelling near the ground. The cubing of the log by means of the end dimensions would give too large a value. Inasmuch as the diameter at breast-height is also measured in a full tree

analysis, this error may be obviated by cubing the butt log as two logs. The length of the lower log would be $4\frac{1}{2}$ feet less the height of the stump. The length of the upper log would be the length of the whole log less that of the lower section. The diameter at breast-height is the upper diameter of the lower section and the lower diameter of the upper section. The author has made tests of the error caused in cubing butt logs by the end-diameter formula and found it as great as 20 percent in small logs and from 5 to 10 percent in large logs.

The second disadvantage of the foregoing formula is that in logs at the upper part of the stem of a tree, knots and swellings are apt to interfere with the measurements. As explained in section 42, the correct diameter may be obtained by measuring just above or below the swelling, or by taking the average of two diameters, one just above and the other just below the swelling.

The formula described above is based on the average of the areas of the two end sections of a log and not on the area of the average diameters of the two ends. Sometimes foresters consider it sufficiently accurate to average the end diameters, find the corresponding basal area, and multiply by the length of the log for the cubic contents. The method is supposed to give the contents of a frustum of a regular cone. As a matter of fact, it gives less than the volume of the cone's frustum. Inasmuch as most logs are larger in volume than a cone having the same end diameters, and the last-mentioned method gives a result less than a cone, it is inaccurate. It is often used by millmen in Europe in buying timber. The method is expressed as a formula thus:

$$V = \left(\frac{D+d}{2} \right)^2 \cdot \frac{\pi}{4} \cdot h,$$

in which V is the volume, h is the length, and D and d are the diameters of the ends of the log. The relation of the volume as given by this formula to the volume of the frustum of a true

paraboloid may be shown by deducting the above expression from that for a paraboloid's frustum.

Thus the difference is:

$$\frac{\pi}{8}h(D^2 + d^2) - \frac{\pi}{4}h\left(\frac{D+d}{2}\right)^2 = \frac{\pi}{4}h\left(\frac{D-d}{2}\right)^2.$$

The method also gives less volume than the frustum of a cone, as may be proved as follows:

$$\frac{\pi}{12}h(D^2 + Dd + d^2) - \frac{\pi}{4}h\left(\frac{D+d}{2}\right)^2 = \frac{\pi}{12}h\left(\frac{D-d}{2}\right)^2.$$

48. Method of Cubing Logs by the Measurement of the Length and of the Diameter at the Middle (Huber's method). The average diameter of the log at its middle point and the length are obtained and the cubic volume calculated by the formula

$$V = B_m \cdot h,$$

in which V is the volume of the log, B_m the area of the middle cross-section, and h the length.

Example.—Suppose a log to have a middle diameter of 15 inches and a length of 30 feet. One finds in a table of areas of circles the area corresponding to 15 inches, namely, 1.227; then $V = 1.227 \times 30 = 36.8$ cubic feet.

This also is a formula for cubing the frustum of a paraboloid. If the log is a section of a true paraboloid the results will be exactly the same as if it were cubed by the Smalian formula. For short logs there is no practical difference in accuracy between the two formulæ. For long logs the middle-diameter formula gives the better results. Butt logs are cubed more accurately by this formula than by the other, unless the breast diameter is used as explained in section 47. In Europe this formula is generally used in scaling logs in the woods. In this country logs are not scaled in cubic feet for commercial purposes. As

soon as Americans begin to use the cubic foot in scaling, this formula will no doubt be used, because it requires the determination of only one diameter (and corresponding area) and the length. It is the simplest of all formulæ in the work on individual logs, both in the field and later in the work of computing in the office.

In some scientific work it is desirable to take diameter measurements at a number of points on a stem or long log at short distances apart. The log may be considered as divided into short logs, say 4 feet each, and the diameters taken at the middle. The cubic contents of all the short sections may then be obtained by the formula

$$V = h(B_{\frac{1}{2}}^1 + B_{\frac{1}{2}}^2 + \dots + B_{\frac{1}{2}}^n),$$

in which V is the volume of the whole, h the length of each short section, and $B_{\frac{1}{2}}^1, B_{\frac{1}{2}}^2, B_{\frac{1}{2}}^3$, etc., are the areas of the respective middle diameters of the short sections. If the long log is not an exact multiple of h , there will be a small end section which must be cubed separately.

49. Method of Cubing Logs by the Measurement of the Length, the Top Diameter, and the Diameter at One-third the Distance from the Butt (Hossfeldt's method).—In this method the length of the log, the diameter at the top, and instead of the base, the diameter at one-third the distance from the base are measured. The log is then cubed by the formula

$$V = \left(\frac{3B_{\frac{1}{3}} + b}{4} \right) h = 3(B_{\frac{1}{3}} + b) \frac{h}{4},$$

in which V is the volume, $B_{\frac{1}{3}}$ is the area of the section measured at one-third distance from the lower base, b is the area of the top section, and h is the length of the log. It will be seen by reference to section 45, that the formula is good, not only for a frustum of a paraboloid, but also for a frustum of a cone. This formula gives more exact results than either of the two preceding. It

has a further advantage of avoiding the root swelling on a butt log. The chief disadvantage is the labor and time required in calculating one-third the length of the log and then locating the point one-third the distance from the large end.

Example.—A log 16 feet long has a top diameter of 10.3 inches and a diameter at one-third its length of 11.5 inches; the volume is

$$V = (3 \times 0.721 + 0.579) \times \frac{16}{4} = 10.968 \text{ cubic feet.}$$

50. Method of Cubing Logs by the Measurement of Two End Diameters, the Middle Diameter, and the Length of the Log (Newton's formula).—This involves three measurements of diameter, that of each end and the middle of the log, in addition to its length. The log is cubed by the formula

$$V = (B + 4B_3 + b) \frac{h}{6},$$

in which V is the volume, B , B_3 , and b are the areas of the lower base, the middle and the top of the log respectively, and h is the length. The method is extremely accurate because it holds true for frustums of the paraboloid, cone, and neiloid. It is to be recommended in case long logs are to be cubed. Where short logs are concerned, one of the two formulæ first mentioned will ordinarily be used, being much simpler in practice and accurate enough.

51. The Method of Fifth Girth.—In this method the average girth of a log at its middle point and the length are determined, and the log is cubed by the formula

$$V = \left(\frac{c}{5}\right)^2 2h,$$

in which V is the volume, h the length, and c the circumference of the log at the middle in feet.

This formula gives almost exactly the total cubic contents

of logs. That this is so, is clear when the formula is compared with the middle-area formula (Smalian's), as follows:

$$V = \frac{\pi}{4} D_m^2 h \sim \left(\frac{c}{5}\right)^2 2h = \left(\frac{D_m \pi}{5}\right)^2 2h.$$

If D_m and h are equal to 1, the comparison becomes

$$\frac{\pi}{4} - \left(\frac{\pi}{5}\right)^2,$$

$$0.7854 - 0.6283^2 \times 2,$$

$$0.7854 - 0.7895.$$

It is used in France to a considerable extent.

52. Burt's Quarter-girth Method.—This method, devised by E. A. P. Burt of London, is based on the quarter-girth method of Hoppus, described in section 55, which gives the cubic contents of square timber contained in logs of different dimensions. In order to determine the full contents of logs, the divisor 113 is used in the formula instead of 144. Burt's formula reads as follows:

$$V = \left(\frac{c}{4}\right)^2 \times h \div 113,$$

in which V is the volume, c is the circumference in inches at the middle, and h the length of the log.

This is another way of expressing the formula:

$$V = \frac{c^2}{4\pi} \times \frac{1}{144} \times h = \frac{c^2}{16} \times \frac{4}{\pi \times 144} \times h.$$

Burt gives the following formula for use when the average diameter is measured:

$$V = \left(\frac{D}{4}\right)^2 \times h \div 183.$$

Complete tables are presented in The Railway Rates Standard Timber Measurer by E. A. P. Burt, and a slide-rule has been constructed for use with this rule.

53. Other Methods Chiefly of Scientific Interest.—A number of other methods have been developed for cubing logs, most of them giving extremely exact results, but so complicated that they will never be used in practice even for scientific work. They are omitted in this book as likely to be of little value to the average American student. Specialists may study them from the original sources, contained in the references given below.

(a) Simony's formula,

$$V = \frac{h}{3}(2(B_{\frac{1}{4}} + B_{\frac{3}{4}}) - B_{\frac{1}{2}}),$$

in which h is the length, $B_{\frac{1}{4}}$, $B_{\frac{1}{2}}$, $B_{\frac{3}{4}}$ are the sectional areas at $\frac{1}{4}$, $\frac{1}{2}$, and $\frac{3}{4}$ respectively of the length of the logs, measured from the lower base.

(b) Breymann's formula,

$$V = \frac{h}{8}(B + 3(B_{\frac{1}{4}} + B_{\frac{3}{4}}) + b),$$

in which V is the volume, h the length, and B , $B_{\frac{1}{4}}$, $B_{\frac{3}{4}}$, and b are the sectional areas taken at the lower base, $\frac{1}{4}$ the length of the log, $\frac{3}{4}$ the length of the log, and at the top respectively.

See *Anleitung zur Holzmesskunst*, by Breymann, Wien, 1868.

(c) Rudolf's formula,

$$V = \frac{\pi}{4}h \left(\frac{D+d}{2} \right)^2 + \frac{2}{3} \cdot \frac{\pi}{4} \cdot h \cdot \left(\frac{D-d}{2} \right)^2,$$

in which V is the volume, h the length, and D and d are the end diameters of the log. By reference to page 93 it will be seen that this method is the same as the average diameter method with a correction which is the mean of the corrections required

to make the formulæ correct for a paraboloid and a cone. Rudolf's formula, therefore, gives the volume of a body midway between the frustums of a cone and a paraboloid.

A number of other formulæ have been devised which are in every case very complicated and of no interest except to the mathematician. They are never used because the simpler methods meet the requirements of all investigations likely to be undertaken. The formulæ which have not been included in the foregoing list are as follows:

1. *Oetzel's formulæ*, see *Neue Formeln zur Berechnung des Rauminhalts voller und abgestutzter Baumschäfte*. G. Oetzel, Wien, 1892.

2. *Walter's formula*, see *Allgemeine Forst. und Jagd-Zeitung*, 1826, page 265.

54. Contents of Logs in Cubic Meters.—On the continent of Europe logs are sold by the cubic meter. The formulæ given above for cubic feet are equally applicable to the cubic meter, and, as the metric system is also used in measuring diameters and lengths, all computations are much simpler than with our own units. Cord-wood is measured in cubic meters.

The author has included in the Appendix a number of tables, for the conversion of the metric units to those used in this country, for the convenience of foresters studying the results of European research. There are also given certain tables of volume in cubic meters, designed especially for Philippine foresters.

CHAPTER VII.

DETERMINATION OF THE CUBIC CONTENTS OF SQUARED LOGS.

55. Method of Quarter Girth.—The length of the log and the average girth are measured and the log is cubed by the formula

$$V = \left(\frac{c}{4}\right)^2 \times h,$$

in which V is the volume, h the length, and c the circumference of the log.

If in this formula c is measured in inches and h in feet, one divides by 144. It is frequently called Hoppus' method. Hoppus published full tables of cubic feet based on this rule, and devised a slide-rule which is used in England.

This formula gives 21½% less cubic contents than the middle-area formula (Smalian's), an amount which is supposed to cover the loss in the manufacture of the lumber.

The method is used in England and in British India. It was formerly used extensively in this country by ship-builders. Daboll's Ready Reckoner, by David A. Daboll, contains tables of cubic contents based on this rule.

56. The Two-thirds Rule.—The two rules most common in this country for determining the amount of square timber contained in round logs are the Two-thirds rule and the Inscribed Square rule.

In the Two-thirds rule the diameter of the log is taken at its

middle point or the diameters of the two ends of the log are averaged. The diameter of the log is reduced one-third to allow for slab and the remaining two-thirds is taken as the width of the square piece which may be hewn or sawn out of the log. The cubic contents of the squared log are then obtained by squaring this width and multiplying by the length of the log.

This rule gives smaller results than the Inscribed square rule, which shows the contents of a square piece that may be exactly inscribed in a cylinder of the same diameter as the log. In support of the Two-thirds rule it is claimed that there is a certain amount of waste due to the fact that logs are seldom perfectly round and straight, and that the rule makes approximately the correct allowance for such irregularities.

57. The Inscribed Square Rule.—This rule gives the cubic contents of square pieces which can be exactly inscribed in cylinders of different sizes. The width of this square piece is usually obtained by multiplying the diameter of the cylinder by 17 and dividing the result by 24, or by multiplying the diameter by 0.7071. This rule of thumb for calculating the width of the inscribed square piece is based on the fact that one side of the square inscribed in a circle 24 inches in diameter is 17 inches long.

The exact mathematical rule for determining the side of a square inscribed in a circle is to square the diameter, divide by 2, and extract the square root. The table in the Appendix was computed by this method.

Practically the same results are obtained by the Seventeen-inch rule, which is based on the fact that a 17-inch log will square 12 inches. According to the Seventeen-inch rule the cubic contents of a log are obtained as follows: Multiply the square of the diameter of the log by its length and divide by the square of 17.

CHAPTER VIII.

CORD MEASURE.

58. The Measurement of Cord-wood.—Fire-wood, small pulp-wood, shingle and heading bolts, and other material cut into short sticks, are usually stacked and measured by the cord. A cord is 128 cubic feet of stacked wood. The standard cord is a stack of wood cut into 4-foot lengths, 4 feet high, and 8 feet long. Sometimes pulp-wood is cut 5 feet long and a stack of it 4 feet high and 8 feet long is considered one cord. In this case the cord contains 160 cubic feet of stacked wood. Where fuel is cut in 5-foot lengths, a stack 4 feet high and $6\frac{1}{2}$ feet long is ordinarily considered one cord, although it makes 130 cubic feet of stacked wood, or 2 feet more than the standard. Another method of measuring 5-foot wood is to consider a stack, which is 4 feet high and 8 feet long, as $1\frac{1}{4}$ cords. The stacks are measured as ordinarily and the total amount increased $\frac{1}{4}$, or 160 cubic feet of stacked wood are considered one cord and the price is made to conform with the increased measure. Where it is desirable to use shorter lengths for special purposes, as 15 inches, 18 inches, 2 feet, 3 feet, etc., a stack of such wood, 4 feet high and 8 feet long, is considered one cord. It is locally known as a short cord. The price is proportionate to the short measure.

A cord-foot is one-eighth of a cord. A cord-foot is a stack of 4-foot wood, 4 feet high and 1 foot long. Farmers frequently speak of a foot of cord-wood, meaning a cord-foot. By the expression "surface feet" is meant the number of square feet measured on the side of a stack.

Cord-wood is usually measured with a long stick marked for the measurement of the length and height of the stack. For the standard 128-foot cord, the stick is 8 feet long, with a notch at the middle for the measurement of the height; or a 4-foot stick is used, the length being twice the length of the stick. The stack should show full measure, that is, the edges of the top sticks should be a few inches above the 4-foot mark. If the stack is on a side hill it should measure 4 feet when the rule is placed perpendicular to the slope of the hill.

In some localities, particularly in New England, cord-wood is measured by means of calipers. Instead of stacking the wood and computing the cords in the ordinary way, the average diameter of each log is determined with calipers and the number of cords obtained by consulting a table which gives the amount of wood in logs of different diameters and lengths, expressed in so-called cylindrical feet. A cylindrical foot is $\frac{1}{128}$ of a cord. A better term would be "stacked cubic foot," as it represents a cubic foot of stacked wood, as opposed to a cubic foot of solid wood. The number of cylindrical or stacked cubic feet in a log is computed by squaring the average diameter of the log in inches, multiplying by the length of the log in feet, and dividing the result by 144. Some tables give the result in feet and inches (stacked cubic, not linear feet).

A special caliper rule for measuring cord-wood has been made by Mr. John Humphrey, of Keene, N. H. Instead of considering a cylindrical or stacked cubic foot equivalent to $\frac{1}{128}$ of a cord, he has assumed it to be equivalent to $\frac{1}{100}$ of a cord. In either case the cylindrical or stacked cubic foot is a purely arbitrary unit and the final results in cords are the same.

In actual practice the table given in the Appendix is used as follows: The number of cylindrical or stacked cubic feet in the different logs is determined by means of calipers and reference to the table, or by means of the calipers alone if the results are inscribed directly upon them. The total number of cylindrical or stacked cubic feet is then divided by 128.

59. Amount of Solid Wood in a Stacked Cord.—It is often necessary for a forester to convert cubic measure into cord measure or vice versa. For example, volume tables in cords are often based on volume tables in cubic measure. The cord is a large and hence rough unit, so that scientific tables of volume and growth are first made in cubic feet and later converted into cord measure. It is, therefore, important to know the ratio between the two units and the conditions which may alter this ratio.

The problem of the solid contents of stacked wood was studied in Germany as early as 1765. Reliable figures were, however, not secured until the experiment stations undertook an exhaustive investigation, the results of which were published in *Untersuchungen über die Festgehalt und das Gewicht des Schichtholzes und der Rinde*, by F. Baur, Augsburg, 1879.

An independent investigation was carried out in Austria leading to practically the same results. (*Mitteilungen der Forstl. Versuchswesen Oestr.* 1877-1881. Report by von Senkendorf.)

The only work of this character done in this country is a limited study in the Adirondacks by R. Zon. (*Forestry Quarterly*, Vol. 1, No. 4, p. 126.)

The results of these studies show that the solid contents of ordinary stacks vary from 51 to 92 cubic feet per cord, and that the exact amount depends on the species, the form and size of the sticks, the length of sticks, the method of piling, and the degree of dryness.

Form of Sticks.—If the sticks are smooth and straight, there will be a greater amount of solid wood in a cord than if there are irregularities, such as stubs of branches, burls, crooks, forks, etc., which increase the air space in the stacks. A favorite trick with choppers working under contract is to put in the stacks irregular and crooked sticks which increase the openings and hence enable them to secure a cord with as little wood as possible. Spruce wood which has been rossed and all the irregularities, as well as the bark, removed, contains a very much larger

amount of solid wood per stack than when the bark is on, not merely because of the removal of the bark, but also because of the removal of irregularities. Ordinarily conifers produce a greater amount of wood per cord than hardwoods, because of the smoother, straighter sticks.

A cord of softwood usually contains about 3% more than one of hardwood. There is naturally a difference between species, as well as between the general classes of hardwood and softwood.

Split Wood.—It is often said by wood-dealers that a cord of wood increases after splitting. In other words, splitting reduces the amount of solid wood in a cord. The reason is that split wood cannot be stacked as closely as round sticks. The flat sides of the split wood tend to increase the amount of open space between the sticks.

Length of Sticks.—Another well-known saying is that a cord of 4-foot wood shrinks after being sawed into short lengths. The reason for this is that the short sticks pack more closely than the long sticks. It is obvious that crooks and irregularities have less effect with 15-inch sticks than with those 4 feet long. The following table illustrates the effect of the length of sticks on the volume of solid wood.

INTERDEPENDENCE OF THE STICK-LENGTH AND THE VOLUME OF SOLID WOOD PER CORD.*

L'gth of Stick, Feet.	Straight Sticks.		Crooked Sticks.		Knotty Sticks.	
	Volume, Cubic Feet.	Difference, Percent.	Volume, Cubic Feet.	Difference, Percent.	Volume, Cubic Feet.	Difference, Percent.
1	99.81	+8.3	93.47	+14.1	89.60	+20.7
2	97.28	+5.5	89.60	+9.4	84.48	+13.8
3	94.72	+2.8	85.76	+4.7	79.36	+6.9
4	92.16	.0	81.92	.0	74.24	.0
5	89.60	-2.8	78.08	-4.7	69.12	-6.9
6	87.04	-5.5	74.24	-9.4	64.00	-13.8

* From König, cited in Dr. Müller's Lehrbuch der Holzmesskunde.

Diameter of Sticks.—It has been found by experiment that there is more solid wood in a cord of big sticks than one of small sticks. This is because there is an increase of air space with the increase in number of sticks. This is true even if all the sticks are very even and straight. This is well shown in the following table:

INTERDEPENDENCE OF DIAMETER OF STICKS AND THE VOLUME OF SOLID WOOD PER CORD.*

Diameter of Stick, Inches.	Number of Sticks per Cord.	Solid Cubic Feet per Cord of		
		Hardwoods.	Softwoods.	Mixed Hardwoods and Softwoods.
6.8	94	102.40	102.40	102.40
6.0	126	94.72	98.56	96.00
4.75	205	88.32	97.28	92.16
3.5	378	79.36	90.88	84.48

Seasoning.—In ordinary practice it is customary not to pay any attention to whether a stick of wood is dry or green. Firewood is piled into cord-wood stacks and the stack is made large enough to counterbalance any shrinkage by drying. As a matter of fact there is considerable shrinking, although it is more or less counteracted by the cracking and checking of the sticks, by the detachment of the bark, etc. Hardwoods shrink more than softwoods. Green hardwood shrinks from 9 to 14%, according to species, and softwood 9 to 10%.

Method of Stacking.—The solid contents of cord-wood stacks depend a great deal on the care and method of stacking. Experience has shown that when one stake is used at the end of the stack, the solid contents are ordinarily higher than when two stakes are used. The explanation of this is that the crooked sticks are blocked by the two stakes, whereas in the case of one stake the ends may extend outside the stack. Choppers frequently put a forked stick around the stake, the two ends being held

* From Untersuchungen über den Festgehalt und das Gewicht des Schichtholzes und der Rinde, by F. BUR.

within the pile by the weight of the wood. This is done to strengthen the stake propping the ends of the stack. It is a common thing to leave brush on the ends of this crotched stick, thereby increasing the space in the stack and reducing the amount of solid wood. This is one of the tricks of the contract chopper.

Foresters generally reckon that a cord of wood contains 70% solid wood. This is on the average run of timber. Where the sticks are very large the factor 80% is used, and where there is a great deal of crooked wood 60%.

An attempt has been made by Mr. Raphael Zon to show the solid contents of cord-wood stacks of different classes of wood. These tables and Mr. Zon's explanation are given below.

"An attempt is made here to present tables in which the solid volume of wood in a cord can be found. Of all the factors influencing the amount of solid wood, only the length and thickness of the stick are taken into account, as being of greater importance and uniform in their effect. The rest are more variable in their influence and are, therefore, less easily computable.

"The wood is divided into several classes according to its thickness. In the first class are sticks more than 5.5" in diameter at the small end. Such sticks are usually derived from the lower part of the trunk; they are free of branches and cylindrical in shape. The best pulp-wood belongs to this class.

"The second class contains sticks 2.5" to 5.5" in diameter. This and the first class are most frequently found together. Most pulp-wood is a mixture of these two classes.

"To the third class belongs wood 1" to 2" in diameter. This and the second class mixed together furnish most of the extract wood, fire-wood, etc.

"Table I gives the solid volume of a cord containing 128 cubic feet of stacked wood for sticks 10" to 14' long. Table II that of stacks 4 feet high, 8 feet long, and 10", 12", 16", etc., wide.

"In order to find the solid volume of a stick length not given in Table II, take the stick length nearest it, divide its solid contents by its length, and multiply the quotient by the log length

desired. Thus, if it be required to find the solid volume of a cord of 13-inch wood, 4 feet high and 8 feet long, divide 23.50 by 12 and multiply the quotient by 13, or divide 27.32 by 14 and multiply by 13. The result in either case will give the solid volume for the required stick length.

“The figures given in the table are average figures, and as such are subject to changes in accordance with local conditions. If,

TABLE I.—VOLUME OF SOLID WOOD PER 128 CUBIC FEET OF SPACE.

Length of Stick.	1st Class, Small Diameter, over 5.5".	2d Class, Small Diameter, 2.5"-5.5".	3d Class, Small Diameter, 1.0"-2.5".	1st and 2d Classes Mixed.	2d and 3d Classes Mixed.
Inches.	Cubic Feet.				
10	91.98	85.40	65.70	88.69	75.55
12	91.80	85.25	65.69	88.53	75.47
14	91.67	85.10	65.65	88.39	75.38
16	91.50	84.95	65.60	88.23	75.28
18	91.37	84.80	65.55	88.09	75.18
20	91.20	84.67	65.50	87.94	75.09
22	91.05	84.50	65.40	87.78	74.95
24	90.90	84.35	65.32	87.63	74.84
26	90.75	84.20	65.23	87.48	74.72
28	90.60	84.05	65.12	87.33	74.59
30	90.45	83.90	65.00	87.18	74.45
Feet.					
3	89.98	83.40	64.60	86.69	74.00
4	88.92	82.42	63.62	85.67	73.02
5	87.75	81.30	62.60	84.53	71.95
6	86.45	80.00	61.60	83.23	70.80
7	85.38	78.82	60.55	82.10	69.69
8	83.75	77.20	59.40	80.48	68.30
9	82.40	75.80	58.20	79.10	67.00
10	81.00	74.30	56.90	77.65	65.60
11	79.60	72.80	55.60	76.20	64.20
12	78.05	71.20	54.25	74.63	62.73
13	76.45	69.60	52.90	73.03	61.25
14	74.85	67.95	51.50	71.40	59.73

for instance, the majority of the trees cut into cord-wood are more than 12.0" in diameter, breast-high, the solid volume of the cord may be raised about 5%. Should the majority of the trees be no larger than 5", the solid volume of the cord may be reduced

about 5%. If the trees have rough, thick bark, the solid volume of the cord may be reduced 3%. Thin-barked trees would raise it 3%. Tall, straight trees, clear of branches to a great height, would raise the solid volume of the cord 10% in first-

TABLE II.—VOLUME OF SOLID WOOD IN STACKS.
(4 ft. high, 8 ft. long, and 10", 12", 14", etc., wide.)

Length of Stick.	1st Class, Small Diameter, over 5.5".	2d Class, Small Diameter, 2.5"-5.5".	3d Class, Small Diameter, 1.0"-2.5".	1st and 2d Classes Mixed.	2d and 3d Classes Mixed.
Inches.	Cubic Feet.				
10	19.50	17.50	14.00	18.50	15.75
12	23.50	21.00	16.00	22.25	18.50
14	27.32	24.50	19.00	25.91	21.75
16	31.00	28.50	21.50	29.75	25.00
18	35.00	32.00	24.30	33.50	28.15
20	37.50	35.00	27.00	36.25	31.00
22	42.20	39.00	30.00	40.60	34.50
24	46.02	42.00	32.70	44.01	37.35
26	50.00	46.00	35.20	48.00	40.60
28	53.21	49.00	38.00	51.11	43.50
30	57.00	53.00	41.00	55.00	47.00
Feet.					
3	68.50	63.00	50.00	65.75	56.50
4	88.92	82.42	63.62	85.67	73.02
5	108.50	101.50	78.00	105.00	89.75
6	128.50	120.00	92.30	124.25	106.15
7	149.55	138.05	106.41	143.80	122.23
8	170.00	165.00	119.90	167.50	142.45
9	190.00	175.00	133.50	182.50	154.25
10	211.00	193.00	147.50	201.00	170.25
11	230.00	210.50	161.20	220.25	185.85
12	250.00	228.00	175.00	239.00	201.50
13	269.00	245.50	189.00	257.25	217.25
14	287.50	262.50	203.00	275.00	232.75

class wood; in the second class, 5%. Low, crooked, and branchy trees would reduce the solid contents 10% and 5% respectively, and so on. As can easily be seen from this, these tables are not absolute for all conditions. To be perfectly correct, such tables should be made for a limited locality. The merit of the tables given, therefore, lies in pointing out the relative solid contents in cords of sticks of different length and diameter, and as such

they ought to prove of value to all industries which buy timber for its actual solid volume, like pulp and extract manufacturers.

“By giving the actual solid volume in cords of different length and diameter, these tables help to establish just and uniform prices, and ought, therefore, to be the basis of all specifications in contracts for pulp-, extract-, or fire-wood.”

60. Relation Between Cord Measure and Board and Standard Measures. It is customary in many localities to compute the contents of logs both in cords and in board feet. Fire-wood is not measured in this way, as it is too small and inferior to use for timber. But pulp-wood and other wood, which is cut into short bolts and is large enough to scale in board measure, is sometimes sold by the cord and sometimes by the thousand board feet. Many persons are accustomed to measure timber by the thousand and are unable readily to reckon by the cord, so that it is convenient to have a converting factor to translate from one measure to the other. Still again, it is often convenient to estimate standing timber entirely by the cord and to calculate the board measure separately. Therefore there have come into use rough converting factors, analogous to the factors for converting board measure to standards and vice versa. In this case, however, there is a great divergence of opinion as to the board contents of a stack of timber. This is natural, because the board contents of stacks differ according to the size and length of the logs, the character of the surface, and, what is often overlooked, the log rule used and the method of scaling. Ordinarily the attempt is made to show into how many cords a given lot of logs will stack when cut into short bolts. The logs are scaled before cutting into bolts; they are scaled by their top diameters; the butts may vary enormously in diameter and irregularity; no regard whatever is taken of the size of the logs. A lot of logs from large virgin trees would yield totally different results than small second growth. It has been shown that the cubic contents of a stack increases with the size of the sticks. The board contents of logs increase with their size in a very much more

rapid rate than cubic feet. The use of the same converting factor with small and with large timber is, therefore, totally incorrect.

All that can be done is to obtain the average amount of board feet in stacks of timber cut in a certain locality where the average size of the sticks, the average form, and irregularities of surface of the timber are uniform. The use of this factor in other localities where the species, the size of timber, and even the method of scaling in board feet are different, would prove inaccurate.

This explains why some give 300 and others 1000 board feet as an equivalent of a cord. In spruce of the New England States 560 is the ordinary translating factor used by many companies. For average-sized timber 550 board feet per cord is a conservative estimate. The conversion of standards to cords is simple because the standard is a unit of solid volume. Ordinarily the Nineteen-inch Standard is considered equivalent to one-third of a cord, or, more exactly, 2.92 standards to the cord.

A fair average ratio between board feet and cubic feet is 6 board feet to each cubic foot. This ratio is consistent with the figures given in the preceding paragraph.

CHAPTER IX.

THE CONTENTS OF ENTIRE FELLED TREES.

61. The Measurement of Entire Felled Trees.—The foregoing sections show how to determine the contents of logs. Many investigations, however, require the contents of trees. The cruiser measures the merchantable contents of felled trees to aid him in estimating the volume of standing trees. Volume tables showing the contents of standing trees of different sizes are based on the measurement of felled trees. When the growth of trees in volume is studied, the contents of whole trees and not merely of individual logs must be determined.

The measurements usually taken are the diameter breast-high, diameter at each cross-cut inside and outside bark, stump height, length of each log, and the length of the top above the last cut. These data enable the computation of the volume of the whole stem and the merchantable volume. If the percent of sapwood is required, the width of sap is measured at each cross-cut.

It has been a common custom in the United States to take measurements for volume in the lumber woods where timber is being cut for the market. The forester measures the trees as soon as cut and before the logs are drawn away from the stumps, and in this way saves the expense of hiring choppers and of paying for the privilege of cutting trees, which often have to be purchased outright. Young trees below merchantable size and trees which cannot be sold for other reasons must be felled specially. In the latter case the forester cuts the trees into such lengths as suit the special requirements of the investigation. When the

forester measures trees cut for the market, the lengths of sections must conform to the regular log lengths. In many cases this varies, as, for example, when logs are cut 10, 12, 14, 16 feet, and perhaps also other lengths. The data secured are of less scientific value than where the logs are all the same length. For most practical purposes of study in old timber, the measurements of logs cut for the market yield satisfactory results.

It is the custom of foresters to classify trees by the diameters at breast-height. Lumbermen more often refer to the stump diameter when speaking of the size of trees. The stump diameter is unsatisfactory because of the varying height of the stump and also because the stump cut is usually within the base swelling of the tree, and is much more variable than the diameter measured above this swelling. Sometimes specifications of trees bought on the stump call for certain diameters at 6 feet above the ground. This is an awkward point to measure, particularly for a short man. The plan of the forester to classify all trees by the diameters at breast-height is the most practical. This point is above the root swelling, and it is the natural place to caliper a standing tree. In America $4\frac{1}{2}$ feet has usually been accepted as the breast-height point. In Germany breast-height is 1.3 meters, or about 4 feet 3 inches. The English have chosen $4\frac{1}{2}$ feet for their work in England and India, and this has been adopted in this country. It is slightly above true breast-height for a short man, but is just right for a man of average height.

In measuring felled trees, therefore, the diameter at breast-height is obtained with the calipers. If the tree is not round, the largest and smallest diameters are averaged as the true diameter. Sometimes the measurer is able to take this diameter before the tree is felled. Otherwise it is necessary to measure it at the proper point on the butt log. To find the breast-height point on the butt log, the average stump-height is measured, and then this amount deducted from 4.5 feet for the distance which must be measured from the base of the log to the breast-height point.

There is often confusion as to where to take the measurement

of the height of the stump. Thus on a side-hill, on a hummock, or other irregularity of ground, the height of the stump is much greater on one side than another. The simplest method is to imagine the same tree growing on level ground and place the lower end of the rule at the point which would represent the plane of the level ground.

When the stump cut is slanting or uneven on account of bad chopping, care must be taken to measure the average height and not the distance from the ground to the highest point or the lowest point of the stump cross-cut. In the same way in measuring from the base of the butt log to the breast-height point, one must be careful to locate the breast-height point exactly $4\frac{1}{2}$ feet above the ground as the tree stood before felling. The scarf at the base of the log often leads to errors by careless measurers.

After measuring the diameter at breast-height, the length and the diameters at the ends of each merchantable log are measured. These figures enable the determination of the merchantable contents of the whole tree in board feet, standards, or cubic feet.

Frequently the trees measured are classified both by diameter breast-high and also by height. In this case the distance from the uppermost cross-cut to the tip of the tree is measured. The sum of the lengths of the logs, plus the stump-height, plus the distance from the uppermost cut to the tip, is the total height of the tree.

The distance above the last cut is measured with a tape or a measuring-rod, usually the former. The measurement is apt to be taken carelessly, because the tape must be stretched in among the branches. It requires some time and patience to stretch a tape through the crown of a tree and secure an accurate measurement. In scientific work an accurate measurement is necessary. In some rough work it is sufficient to take the measurement on one side of the crown, calculating the limits by the eye, or even to pace beside the crown to obtain the length of the top piece. For classification of trees by height classes a rough estimate of height may suffice. In the study of growth and similar work the total length

of the trees must be determined accurately. Sometimes young foresters are confused in locating the tip of a hardwood tree which has an irregular top. If the crown is rounded, imagine a tangent perpendicular to the tree's axis and let this be the top. If the crown is very irregular the highest point is taken as the tip. Sometimes the computed height is slightly greater than the true height of the tree because the result is the sum of the lengths of several sections, some of which bend from the perpendicular line of the tree. The effort should always be not to measure abnormal trees. Ordinary trees offer no practical difficulties.

An accurate determination of volume of the whole stem is required in certain scientific investigations. Sometimes volume tables are based on the entire stem contents, as explained later. The form of trees may be compared better when the entire stem or the stem down to a certain fixed diameter is cubed than when simply the merchantable contents are determined. Certain studies of growth also require the stem contents.

The measurements in the field are the same as described above, except that diameter measurements are taken above the uppermost merchantable cut. Ordinarily in measuring timber trees, the top, i.e., the portion of the stem above the last merchantable cut, is divided into 10-foot sections and diameter and length measurements taken, just as on the merchantable logs. Where small trees which are not large enough for sawlogs are measured for volume, the sections are made 10 feet in length. If there is a cord-wood market for 4-foot sticks, the sections are made 8 feet long. If very exact data are required, diameter measurements are taken on the stems every 4 feet.

62. The Computation of Volume.—The contents of an entire stem are determined as follows: Each log or bolt is cubed as the frustum of a paraboloid; in this country usually by the end diameter method (Smalian's method). The top piece, i.e., the small piece from the last cut to the tip, is ordinarily cubed as a cone, i.e., by the formula, $V = \frac{B \times h}{3}$, in which V is the volume,

B the area of the last cross-cut, and h the length of the top piece. If the stump is included, it is generally considered a cylinder with a diameter equal to the diameter of the stump. The formula is $V = Bh$, in which V is the volume, B the area of the stump cut, and h the stump-height. Naturally this method of cubing the stump does not include all of the wood because there is a considerable flare on every stump. It has been found, however, that this root flare is so variable that better results are obtained by disregarding it and considering all stumps as cylinders.

In investigations in this country, the cubic contents of branches are determined only in the case of old hardwoods with large branches, which will make merchantable cord-wood. Only such parts are measured as are salable. The limbs are cut into regular lengths, usually 4 feet, and diameter measurements taken as on the sections of the stem. Inasmuch as there is often only one stick in a limb and the pieces are in consequence isolated individuals, the middle diameter and length are taken and the pieces cubed by the middle-diameter formula (Huber's). In this country no studies have ever been made of the contents of the smaller parts of the branches or of the roots. In Europe such material is often salable. It is doubtful if American forestry will need any such studies for a long time. Even scientific studies comparing the contents of trees growing under different conditions will probably be based on measurements to a fixed diameter of branch, say 2 inches, instead of including the twigs.

In Europe the contents of very small and irregular parts of trees are cubed by means of the xylometer. This consists of a large cylindrical vessel, which is graduated inside, or by a tube outside, to show the volume of water contained in it. The volume of irregular sticks or pieces of roots may be obtained by immersing them in the xylometer and determining the amount of water displaced. Another form of xylometer has a spout from which water flows when the wood is immersed, the water being caught and measured in a separate vessel. When considerable quantities of wood are measured, the whole is weighed, then a small

portion, which is weighed separately, is cubed by the xylometer; and then the entire mass cubed by assuming that the weight and volume are proportionate. If W is the weight of the whole, w the weight of the small portions selected for cubing, V the volume of the whole, and v the volume of the portion cubed,

$$V : v = W : w \quad \text{or} \quad V = \frac{W}{w}v.$$

63. The Measurement of Crown, Clear Length, and Merchantable Length.—The measurements described in section 61 may be summarized as (a) diameter breast-high, (b) diameter at each cross-cut, (c) stump-height, (d) length of each log and the top above last cut. Other measurements often required by investigations of volume are as follows (letters to continue the measurements above summarized):

(e) *Clear length.*—The purpose of this measurement is to enable the estimate of the amount of each tree which has clear lumber. The figures obtained are averaged together to assist a cruiser in estimating the percentage of clear in a specified forest, or to assist in the valuation of timber and an estimate of the classes of lumber for which a specified lot may be used. In this case clear length means the length of the trunk yielding clear lumber. Often, however, the purpose of the measurement is to study natural pruning, in which case clear length may refer to the length of trunk clear of branches or branches of a certain size. In all cases the records should make it plain to what clear length refers.

(f) *Merchantable length.*—This is the distance from the stump to the point on the stem where it is no longer of a merchantable size or quality. Ordinarily the measurement is taken without regard to the cutting of the stem into short logs. It is as if the stem were to be cut at the highest possible point in the tree and then be taken out whole, as is often done with spruce. Certain studies require as the merchantable length the sum of the lengths

of the merchantable logs. The term *used length* is employed for the length which can be utilized. Often it is desirable to know what the tree contains, on the assumption of cutting to a lower limit. For example, if the average limit were 8 inches, one might wish to know the contents, were it possible to use the timber down to an average of 4 inches. In that case the possible merchantable length would be the distance from the stump to the 4-inch point, or as near that point as the timber continued to be of merchantable quality. When the contents of trees are taken to a fixed limit, as, for example, 3 inches, regardless of whether the upper part is of merchantable quality, the measurement of length from the stump or ground to this minimum point should not be called the possible merchantable length, but the "length to 3-inch point" or similar clear phrase. The confusion arising regarding the meaning of merchantable length may in this way easily be avoided.

(g) *Length of crown*.—Just as in the case of the merchantable length, foresters have not in all cases agreed regarding the exact meaning of the length of crown. The crown is measured for descriptive purposes alone. It is entirely to explain the form of the bole as indicated by its volume, and in case of full tree analyses to explain the rate of growth found. The character of the stem must be ascertained by the clear length and special description. The length of crown, then, refers to the length of the crown proper, and not necessarily to the distance from the tip of the tree to the lowest green limb. It may happen that a green limb is isolated from the crown proper and some 5 to 15 feet below it. If the distance from the tip to the lowest green limb is called the length of crown, it would indicate that this is all crown, whereas the extra limb plays an insignificant part in wood production. The measurer should regard the crown by itself, as the part of the tree affecting the growth, and take its length by itself, throwing out the occasional branches which are of but little importance, and which if included would mislead in the conception of the assimilating surface of the tree.

(h) *Width of Crown.*—This measurement is often omitted, but is exactly as important as the length of crown. The two measurements together give an admirable mental picture of the crown, and are necessary when comparing the volume of trees of the same size from different places. It may be measured by a tape or estimated. Being a measurement primarily for description, exactness is not an essential.

64. Description of the Tree Measured. (1) *The Tree Class.*—If the tree grows in a stand which is even-aged or approximately so, the tree should be distinguished as dominant, intermediate, or suppressed. In an uneven-aged stand this distinction may not

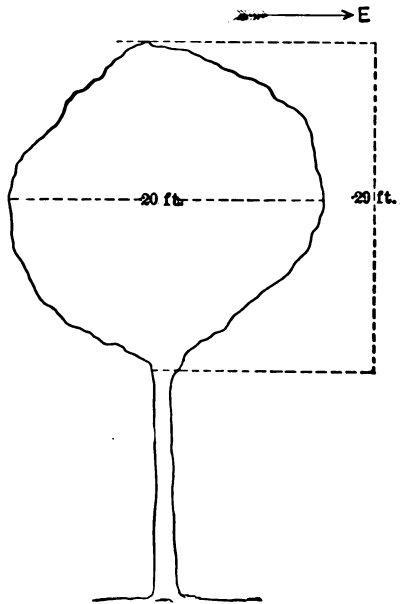

FIG. 14.

always be made. The rule is that the tree class is named when possible. If it clearly cannot be assigned to any class, as, for instance, a thrifty twenty-year-old tree among, but not crowded by, eighty-year-old trees, a full description of the tree may suffice.

(2) *Crown Description*.—This is designed to supplement the measurements of the crown. It may be expressed in words, but still better by a diagram, showing the shape of the crown. If a crown is one sided it requires a number of words to give a clear description of the shape. Fig. 14 shows a sketch of a vertical section of a crown, together with the measurements. It shows also the shape of the trunk, answering the purpose of word description.

(3) *Description of the Stem*.—Usually the stem is described as round or elliptical, straight, crooked, with a sweep at butt, tapering or full boled, etc.

(4) *Thrift and Vigor*.—Note should be made whether the tree is vigorous and thrifty, or sickly, apparently rapid-growing or slow-growing. If there is anything unusual about the tree it is described, as for instance a dead top, dead limbs in the crown, a swollen butt, shaky at butt, rotten at heart, etc.

The measurements of felled trees are recorded on special forms, like that shown below, which is used by the forest officers of Massachusetts. The U. S. Forest Service uses for this purpose the regular tree-analysis blank, described on page 264.

Locality, Milford, Pike Co., Penn.

Date, July 28, 1905. No. 31.

Type, Chestnut, Qual. II.

Species, Chestnut.

Total height, 53.6 Feet. D. B. H.* 8 Inches.

Class, Dominant.

Length Crown, 26.6 Feet. Width Crown, 19 Feet.

Length of Section.	D. O. B.†	Width of Bark.	D. I. B.‡	Volume with Bark.
Feet.	Inches.			Cubic Feet.
0.8	8.0	0.4	7.2	
10.	6.8	0.35	6.1	3.0
10.	6.2	0.4	5.4	2.3
10.	4.2	0.25	3.7	1.5
10.	2.6	0.25	2.1	0.7
12.8				

* Diameter breast-high.

† Diameter outside bark.

‡ Diameter inside bark.

CHAPTER X.

THE DETERMINATION OF THE HEIGHT OF STANDING TREES.

65. Rough Methods of Measurement.—It is often necessary in forestry to determine the total height of a standing tree, its merchantable length, clear length, length of crown, or the height above the ground of a certain point on the trunk. In the practical work of timber cruising an estimate of height is often sufficiently accurate. A height measure is valuable to the cruiser chiefly in training his eye to estimate heights, and in testing his judgment by an occasional exact measurement. A woodsman can train himself by practice to estimate the height of a tree within 5 to 10 feet. Some are able to make this estimate merely by looking at the tree. Others find it easier to divide the shaft, mentally, into 10-foot sections, and to estimate the number of these sections.

There are several methods of measuring without an instrument the height of a standing tree. One of the simplest is to measure the shadow of the tree and the shadow of a straight pole of known length set perpendicular to the earth. Multiply the length of the shadow of the tree by the length of the pole and divide the product by the length of the shadow of the pole. The result will be the height of the tree.

A method used when the sun is not shining is to set two poles in a line with the tree. (See Fig. 15.) From a point on one pole sight across the second pole to the base and to the top of the tree. Let an assistant note the points where the lines of

vision cross the second pole and measure the distance between these points. Also measure the distances from the sighting-point on the first pole to the base of the tree and to the lowest vision-

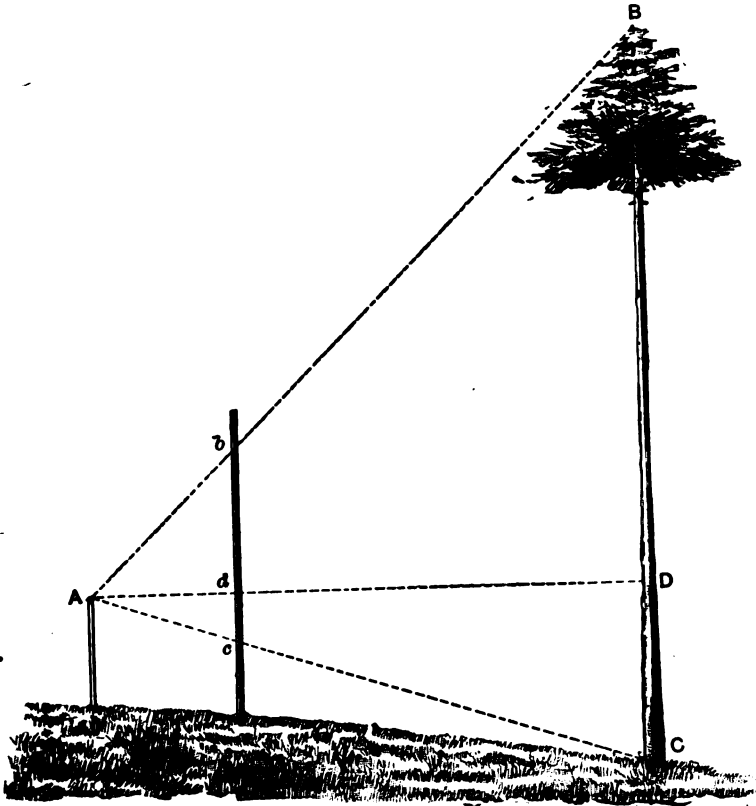

FIG 15.

point on the second pole. Multiply the distance between the upper and lower vision-points on the second pole by the longer of the other two measurements and divide by the shorter; the result will be the height of the tree.

Example: Let $bc=6$; $Ac=4$; and $AC=30$; then $\frac{6 \times 30}{4} = 45$, height of tree.

Another method sometimes used is as follows: The observer walks on level ground to a distance from the foot of the tree about equal to its estimated height. He then lies on his back, stretched at full length, and an assistant notes on a perpendicular staff erected at his feet the exact point where his line of vision to the top of the tree crosses the staff. The height of this point from the ground is measured and the observer's own height. Then the height of the tree is the product of the distance measured on the staff and the distance from the observer's eye to the tree divided by the observer's height.

There are other rough methods of measuring heights, based on the principle of similar triangles. They are not of sufficient value to justify a description in this book.

66. Height Measures.—Many instruments have been devised for measuring the height of a standing tree. In Müller's *Holz-messkunde*, about thirty different height measures are described; and since the publication of that work, several new ones have been invented. A complete description of all these instruments seems to the author unnecessary. Therefore only those which are likely to be of value to the American forester are described in full. Mention is made of others which are on the market, with their cost and the firms manufacturing them.

Height measures, often called hypsometers, are based either on the geometric principles of similar triangles or on the trigonometric principle of measuring angles. The principal geometric instruments are the Faustmann, Weise, Klaussner, Winkler and Christen height measures. The trigonometric instruments are the Brandis, Abney and Goulier height measures.

67. The Faustmann Height Measure.—This instrument, shown in Fig. 16, consists of a skeleton rectangular metal frame having two cross-bars at one side of its longitudinal center, the frame and bars being in one piece. A slide, reversible end for end and having beveled edges, works in undercut grooves formed in the inner edges of the cross-bars. This slide is provided at its ends with thumb-notches, and with transversely arranged index marks,

designated I and II. A plumb-line carrying a plummet is attached to the slide in the center of the index mark II. A retaining spring secured to the back of the frame and bearing against the inner face of the slide holds it in any position in which it may be set.

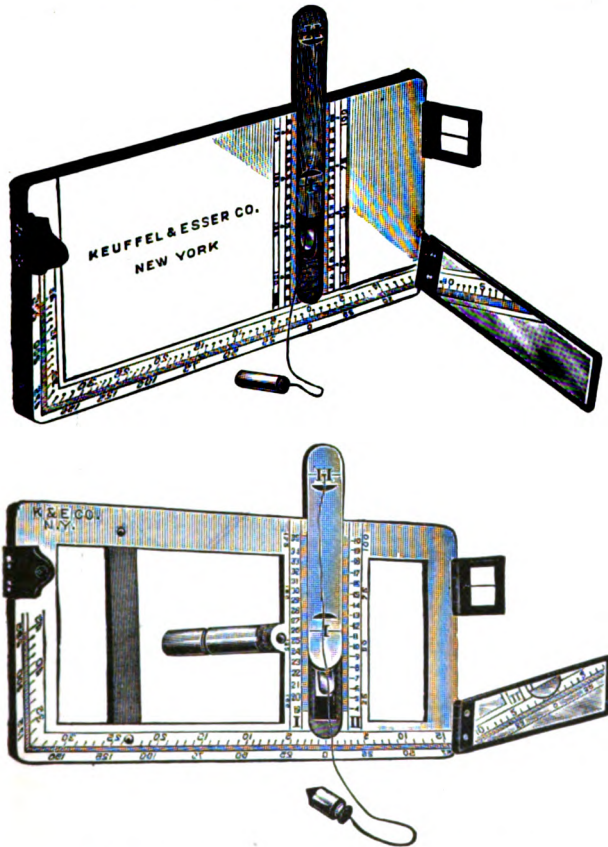

FIG. 15.—The Faustmann Height Measure.

The left-hand end-bar of the frame is furnished with an eyepiece, and the right-hand end-bar with an objective, both of metal, and hinged so as to be folded down out of the way when the device is not in use. A long, narrow mirror is hinged to the

frame at a point below the objective, so as to reflect a right-hand horizontal scale and a left-hand horizontal scale engraved upon the lower bar of the frame, and meeting at a zero-point, which is intersected by a line passing through the longitudinal center of the slide. The right-hand scale runs to 75 and the left-hand scale to 225, the latter scale continuing upward on the left-hand end-bar of the frame.

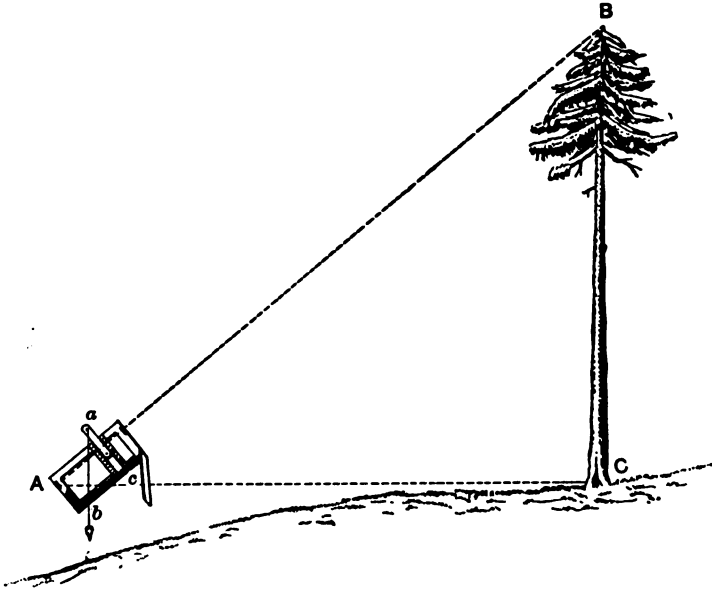

FIG. 17.

The right-hand cross-bar is provided with a vertical scale running upward from zero to 100, and continued on the left-hand cross-bar with a scale running upward to 175. These scales are divided in fifths and numbered. The lines forming the scales are equally separated from each other and represent units of distance under any system of measurement that may be adopted. The handle of the device is attached to the left-hand cross-bar.

A cheaper form of the instrument has a solid wooden frame and slide, and the scales are stamped on inlaid white composition.

The operation of this instrument is based on the geometric principle of similar triangles. To take the simplest possible case first, suppose the eye of the observer is exactly on a horizontal plane with the base of the tree. When the instrument is sighted to the tip of the tree a triangle is formed by the intersection of

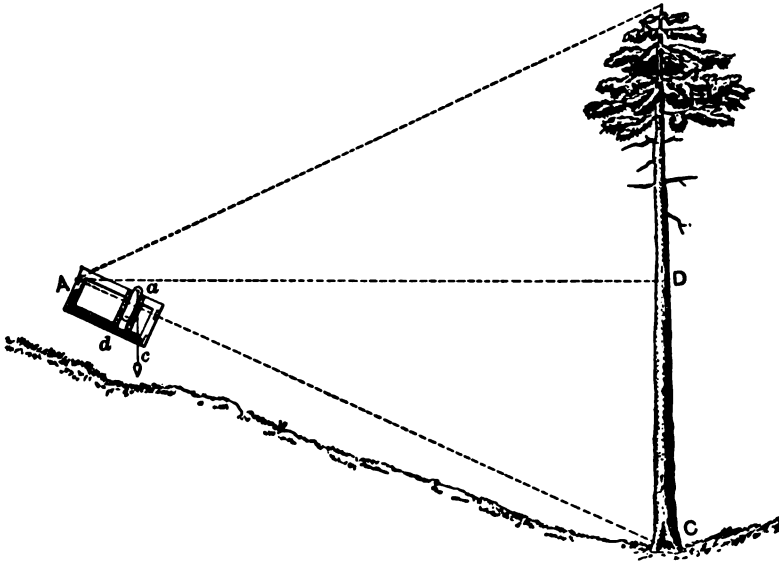

FIG. 18.

the plumb-line, the horizontal scale, and the vertical scale. This triangle is similar to that formed by the tree and the lines of vision from the eye to the tip and base. Thus in Fig. 17, the triangles ABC and abc are similar and $\frac{AC}{ac} = \frac{BC}{bc}$. If the slide of the instrument is so set that ac , measured on the vertical scale, has the same number of units as AC , then the number of units in

bc , measured on the horizontal scale, will be the height of the tree.

Suppose, however, that the observer's eye is not exactly on a horizontal plane with the base of the tree, but is above it. The measurement taken, as just described, would give only the height of the tree above the point which is on the same plane with the eye, D in Fig. 18. It is necessary, therefore, to determine by

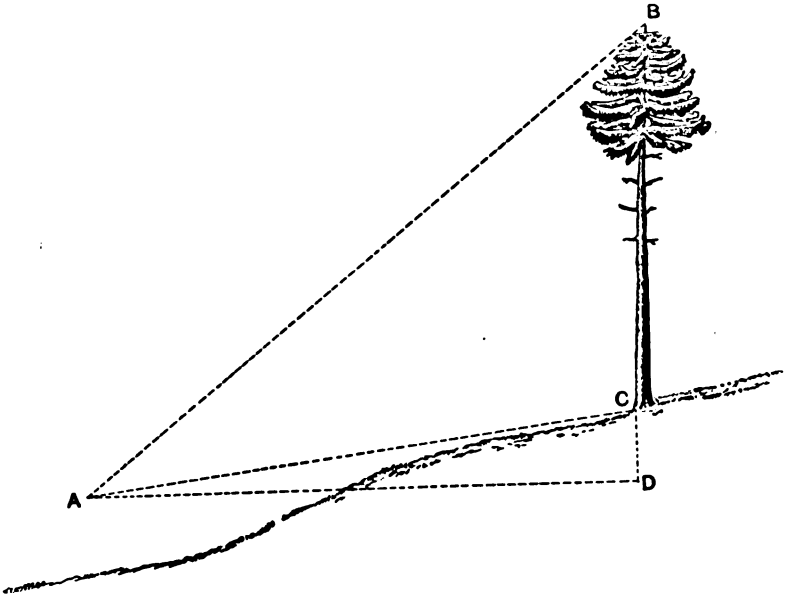

FIG. 19.

a separate measurement, DC , the portion of the trunk below the level of the eye.

For this purpose the instrument is sighted to the base as in Fig. 18 and again two similar triangles are formed, namely ADC and adc . Since on the instrument ad represents the same number of units as AD , then dc is the required distance below the observer's eye. This value added to the first reading gives the total height of the tree.

Suppose the observer's eye is below the level of the base of the tree, as in Fig. 19. He first measures the horizontal distance to the tree, and then, setting his instrument as described above, sights to the tree top. The reading on the horizontal scale gives the distance BD , from the level of the eye to the tip. Then sighting to the base of the tree, the observer obtains the

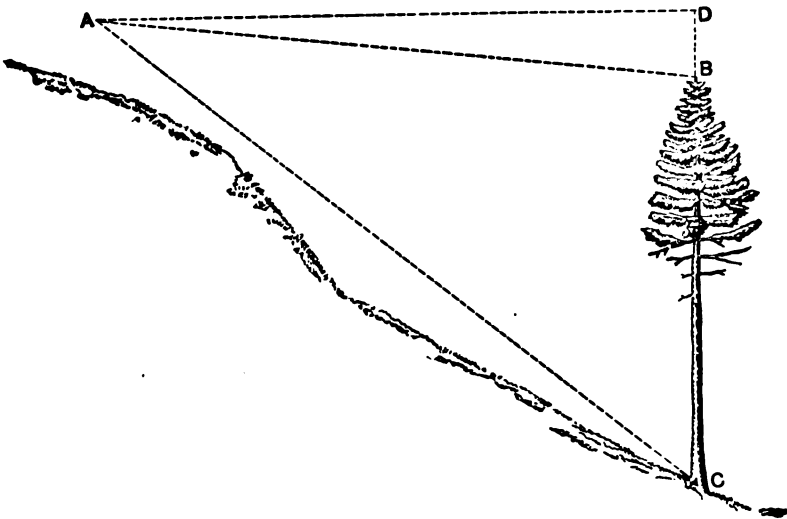

FIG. 20.

distance CD , which, subtracted from the value BD , gives the height of the tree.

Another case is where the observer stands on a slope and measures a tree below. (Fig. 20.) After determining AD , he sights the instrument to C and finds the value of CD , namely, the distance from the level of the eye to the base. Then he sights to B and obtains the distance between the tree's tip and the level of his eye. This reading subtracted from the first gives the total height of the tree.

In using the instrument, a point of observation is chosen where the tip and base of the tree can be distinctly seen; then the

horizontal distance to the trunk is accurately measured with a tape. The slide of the instrument is set so that the distance between the point of suspension of the plumb-line and the horizontal scale corresponds to the distance from the observer to the tree. If this last distance is less than 20 units (feet, yards, meters, or other unit), the slide is set with the index mark II pointing down, and the right-hand vertical scale is used. If the distance from the tree is more than 20 units the slide is inverted, and the left-hand vertical scale is used. The observer then takes the instrument in the left hand and sights to the tip of the tree, the right hand holding the folding mirror and at the same time steadying the instrument. When the plumb-line comes to rest the point of intersection with the left-hand horizontal scale is read in the mirror. This reading is the distance from the level of the eye to the tip of the tree. If the base of the tree is below the level of the eye, the observer sights the instrument to the foot of the tree and takes a reading from the right-hand horizontal scale, which gives the distance below the level of the eye. This must be added to the first reading for the total height of the tree. If the base of the tree is above the level of the eye, the observation is first taken to the tip of the tree and then to the base and the latter subtracted from the first. If the tip of the tree is below the level of the eye, an observation is taken to the base and then to the tip, the difference being the total height.

The Faustmann height measure is compact, light, and well adapted for rough work. The only delicate part is the mirror, which folds against the face of the instrument; it is not apt to be broken except by very careless usage. It is extremely accurate when used by a trained hand. With practice one should be able to measure trees not over a hundred feet high within a foot and those not over 50 feet high within 6 inches. Trees above 100 feet can be measured accurately, provided one can find a point of observation where both the tip and the base can be easily seen. When the instrument is in constant use, it is necessary

to renew the thread frequently, as it is apt to become frayed and cause inaccurate readings. It is difficult to use the instrument in a strong wind, because the plumb-line is light and easily moved. But, as most work with a height measure is in the woods sheltered from high winds, this is not a serious objection to the instrument. The steel instrument costs \$19.50 in this country and 35 marks in Germany. The wooden form costs in Germany from 6.50 to

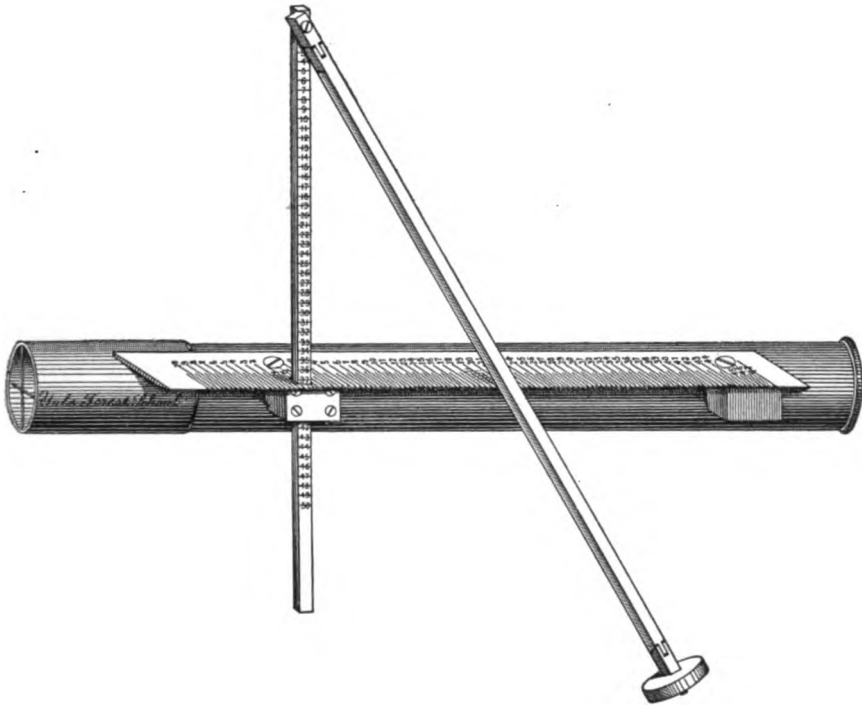

FIG. 21.—The Weise Height Measure.

12 marks and \$6.50 in America. They may be purchased from Keuffel & Esser Co., N. Y., W. Spörhase, Giessen, and L. Tesdorpf, Stuttgart, Germany.

68. The Weise Height Measure.—This instrument consists of a metal telescope barrel 9 inches long, fitted at one end with a

peep-sight and at the other end with stout cross-wires. The former is on a separate tube which fits closely in the telescope barrel. A strip of metal is fixed tangent at its right-hand edge to the periphery of the barrel. On this strip is graduated a right-hand and left-hand scale, which meet at a zero point near the objective. The right-hand scale has 47 and the left-hand scale 10 graduations. There is a notch at each graduation mark indenting the outside edge of the strip. A detachable metal bar, square in cross-section, fits in an opening in the plate at the zero point of the scales, and is held in place by a retaining-spring. A pendulum whose rod is triangular in cross-section is suspended by a universal joint from the upper end of the bar. The sliding bar has on one side a scale with graduations corresponding to those of the metal strip. When the instrument is not in use, the sliding bar is detached and packed inside the barrel.

This height measure is constructed on the same principle as Faustmann's. The scale on the strip corresponds to the horizontal scale of the Faustmann and the graduated bar corresponds to the vertical slide. The instrument is used in the same way as Faustmann's. After selecting a station whence the tip and the base of the tree may be seen, and measuring the horizontal distance from the tree, the sliding bar is set to correspond to the distance from the tree. The observer holds the instrument in his right hand, and, as he sights to the tip of the tree, turns it over to the left enough to allow the pendulum to swing free from the notched strip. As soon as a satisfactory sight is obtained, the instrument is turned over to the right and the pendulum caught in the opposite notch. The reading taken at that point shows the distance from the level of the eye to the tip of the tree. The distance of the foot of the tree below the level of the eye is then obtained and added to the first result as the height of the tree.

The Weise height measure is very compact and strong and therefore well adapted to forest work. The chief advantage of the instrument is that the notches catch the pendulum and hold it in place when the sighting is completed, thus obviating the

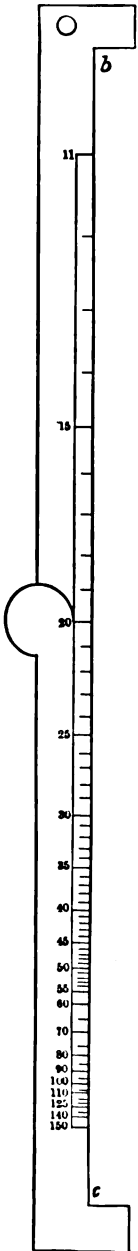

FIG. 22.—The Christen Height Measure.

disadvantage of a limber line which may alter its position after the eye leaves the sight. When used by a practiced hand it is very rapid, probably somewhat more so than the Faustmann height measure. On the other hand, the notches prevent the possibility of a reading closer than $\frac{1}{2}$ unit. It is therefore not as accurate as the Faustmann height measure.

The instrument may be purchased from W. Spörhase, Giessen, Germany, price (in Germany) 12 marks; L. Tesdorpf, Stuttgart, Germany, price (in Germany) 13–15.50 marks.

69. The Christen Height Measure.—This instrument consists of a metal strip 16 inches long, of the shape shown in Fig. 22. The instrument shown in Fig. 22 is made of two pieces hinged together, which are folded when it is not in use. A hole is pierced in the upper end, from which it is suspended between the fingers. Along the inner edge is a scale which gives directly the readings for heights. The instrument is used as follows: A 10-foot pole is set against the tree. The observer stands at a convenient station whence he can see the tip and base of the tree and also the top of the 10-foot pole. The instrument is suspended before the eye and moved back and forth until the edge *b* is in line of vision to the tip of the tree and the edge *c* in line of vision with the base. The point where the line of vision from the eye to the top of the 10-foot pole intersects the inner edge of the instrument indicates on the scale the height of the tree.

Each instrument is constructed for use with a specified length of pole. The instrument de-

scribed above is one designed by the author for convenience with the use of English units. It was constructed in the following way: The distance bc on the instrument was chosen arbitrarily as 15 inches and the length of the pole as 10

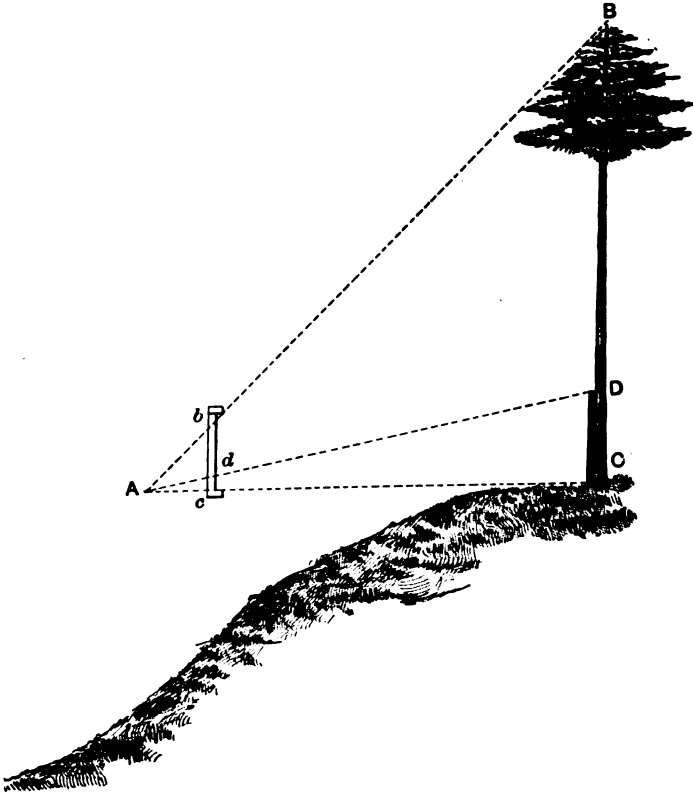

FIG. 23.

feet. It would, of course, be possible to construct an instrument for a pole 12 feet or any other length and on a basis of any desired length of instrument. The theory of the construction of Christen's instrument may be shown by Fig. 23.

When used as above described, two pairs of similar triangles are formed: ABC , and Abc ; ADC , and Adc , in which $BC = \frac{bc \times DC}{dc}$ and $dc = \frac{bc \times DC}{BC}$. With a known value of DC and bc , dc may be determined for all different heights which are likely to be required. Thus it may be assumed that it would not be necessary to measure trees less than 20 feet high, so that the lowest graduation on the instrument is made for that height. To find the proper point for the 20-foot graduation on the scale, the following formula was used:

$$\frac{BC}{DC} = \frac{bc}{dc} \quad \text{or} \quad \frac{20}{10} = \frac{15}{dc} \quad \text{or} \quad dc = \frac{150}{20} = 5.7 \text{ inches.}$$

This same method was used to determine the value of dc for a 25-, 30-, 35-, 40-foot tree, etc., up to 150 feet, and the proper graduations made on the scale. The scale is somewhat more easily read when a notch is made at each graduation.

The instrument is light and compact, and with practice can be used very rapidly, provided one has an assistant to manage the 10-foot pole. It requires no measurement of distance from the tree and the height is obtained by one observation, whereas in the instruments already described two measurements are necessary except when the base of the tree happens to be exactly on a level with the eye. It is more rapid than either the Faustmann or Weise instrument.

Its disadvantages are that it requires a very steady and practiced hand to secure accuracy; that it cannot be used accurately for tall trees; and that it is not adapted for steady work because it is extremely tiresome to hold the arm in the position required. This last objection may be overcome by using a staff to support the hand.

70. The Klausner Height Measure.—The base of this instrument is a flat metal rule 6 inches long, at one end of which is

hinged a sighting-rule slightly longer and thinner than the base and with one side cut out and beveled to a sharp edge. Each of these two rules has a hair-line sight at its further end. At their joint is a revoluble peep-sight, which can be directed by a milled disc to either of the two hair-lines. The sighting-rule may be raised by means of a high-pitch thumb-screw attached to the base-rule near the joint. The base-rule is graduated into 50

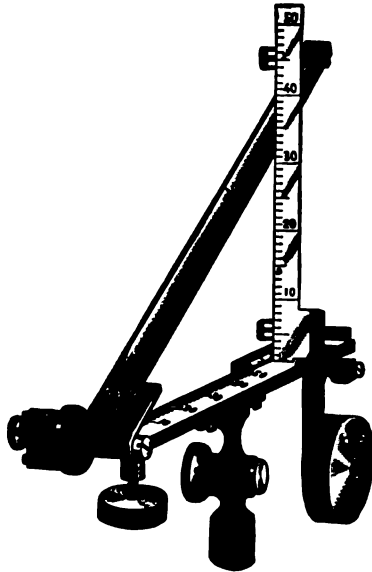

FIG. 24.—The Klaussner Height Measure.

equal parts, each divided into halves, and forms the distance scale; the zero-point being at the joint of the two rules. Attached to the base-rule is a closely fitting slide carrying a thin metal strip, which is always kept in a vertical position by a weight. This strip is graduated like the base-rule, and constitutes the altitude scale. The instrument has a jointed ferule with clamp screw threaded to fit an ordinary camera tripod.

In use, the instrument is set on a tripod at a station whence the tip and base of the tree can be distinctly seen. The oblique

distance from the eye to the foot of the tree is measured and the slide is set at a point to correspond to this distance. The base rule is sighted to the foot of the tree and the sighting-rule is then raised by turning the thumb-screw until the tip of the tree may be sighted. The height of the tree is read from the altitude scale at the point where it is intersected by the sighting-rule.

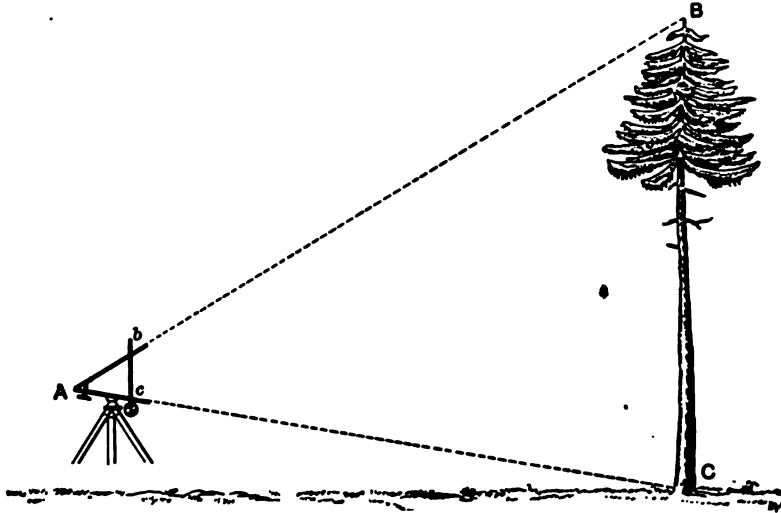

FIG. 25.

The theory of the Klaussner height measure is clear from Fig. 25. The instrument is set so that Ac represents the number of feet, yards, or other units in the distance AC . The triangle, formed by the base- and sighting-rules and the altitude scale, is similar to ABC , and $\frac{BC}{bc} = \frac{AC}{ac}$. ac has the same number of units as AC , so that the number of units in bc is the height of the tree.

The chief advantage of the instrument is that it is fitted to a tripod and is therefore not subject to the error due to the shaking of the hand or to an unsteady eye. It is, therefore, the most accurate of all the small instruments. A second advantage is

that only one observation is required. It is not so compact as the instruments already described and it is more easily thrown out of adjustment. It is particularly well suited to work of a scientific character which requires accuracy. In most rough

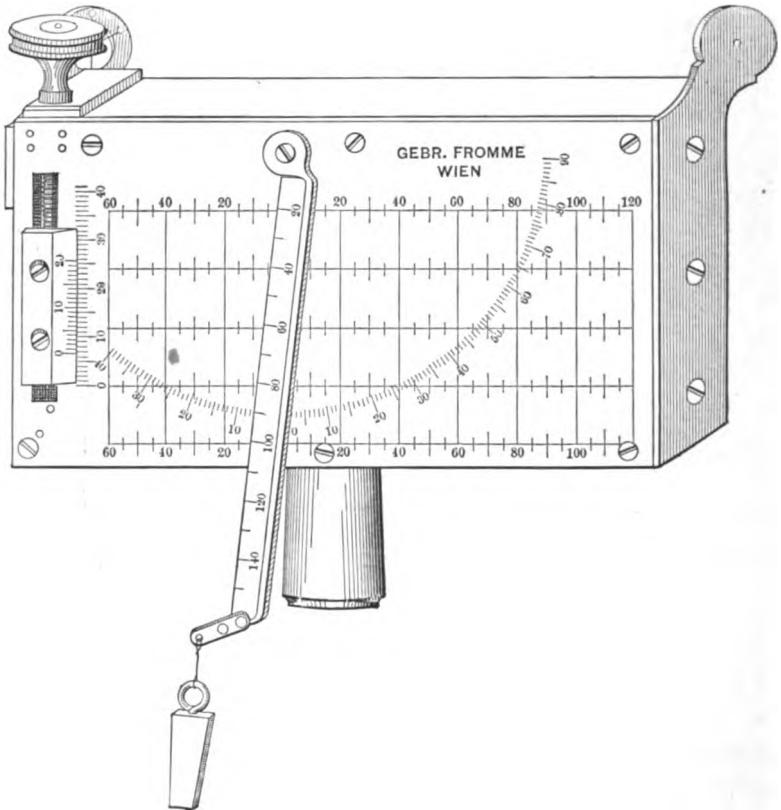

FIG. 26.—The Winkler Height Measure.

forest work, hand-instruments are preferred on account of the burden of transporting a tripod.

The Klaussner height measure may be purchased from Keuffel & Esser Co., N. Y., for \$26.00, or from Wm. Spörhase, Giessen, Germany for 40 marks.

71. The Winkler Height Measure and Dendrometer.—This instrument consists of a shallow box $5\frac{1}{2}$ inches long, 3 inches wide, and 1 inch deep. Against one face of the box is attached a metal plate on which are marked off vertical and horizontal lines, making a series of squares. The horizontal lines are further subdivided and constitute a series of altitude scales. Each horizontal line has a right-hand and left-hand scale meeting at a zero-point to the left of the center of the instrument. The vertical line passing through the zero-point of the altitude scales is graduated as a distance scale. Suspended from the zero-point of this distance scale is a narrow flat metal pendulum bevelled on one side to a sharp edge and carrying at the end a short line and plummet. A scale is graduated on the pendulum in the same units as the altitude scales. On the upper edge of the instrument are two upright plates, the one having a peep-sight and the other fitted with cross-hairs, constituting together a line of sight. The instrument is mounted on a jointed stand-ard, which may be fitted on a tripod or held in the hand.

By the construction of the instrument the observer must stand at 20, 40, 60, 80, or 100 feet from the tree. There is no sliding distance-scale, as in the Faustmann height measure, but the different horizontal lines correspond to specified distances from the tree. If the observer stands 100 feet away from the tree the 100-foot altitude scale is used. If the observer is 80 feet from the tree, the 80-foot altitude scale, that is, the second one from the bottom, is used. When the instrument is sighted to the tip of the tree the intersection of the right-hand scale with the metal strip marks the distance from the level of the eye to the tip. The distance from the level of the eye to the base of the tree is obtained from the left-hand scale by sighting to the foot of the tree.

If this instrument did not have the box construction necessary for its use as a dendrometer, it would be one of the most practical of all height measures. As it is ordinarily constructed, the graduations of the altitude scales are made for every five units, giving readings which are too rough for precise work. This

objection could be easily obviated by a finer division of the scales. Another objection to the instrument is that the observer has a choice of only a few specified distances at which he must stand. This could be obviated by adding other horizontal lines, one for each 10 feet instead of 20 feet.

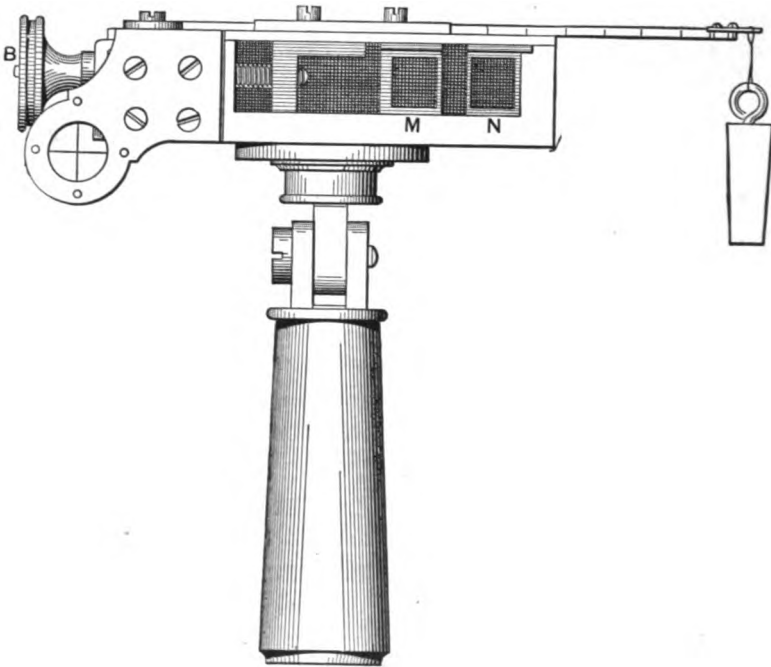

FIG. 27.—The Winkler Instrument used as a Dendrometer.

When the Winkler instrument is used as a dendrometer, a special line of sight is used. The ocular consists of a minute hole in the metal plate which covers the right end of the instrument. At the other end of the instrument and inside the box is an objective opening in which are fitted, perpendicular to the axis of the instrument, two metal plates, *M* and *N* (Fig. 27), of which *N* is stationary and *M* may be moved by means of the thumb-screw *B*. Attached to the plate *M* is a

vernier plate which moves over a diameter scale marked on the face of the instrument and indicates the distance between the two plates *M* and *N*.

When used as a dendrometer the instrument is placed on a tripod in a horizontal position, as shown in Fig. 27. A station is chosen at 20, 40, 60, 80, or 100 feet from the tree, where the point on a tree whose diameter is required can be distinctly seen. The observer then tips the instrument and sights through the box to the point to be measured. The thumb-screw is turned

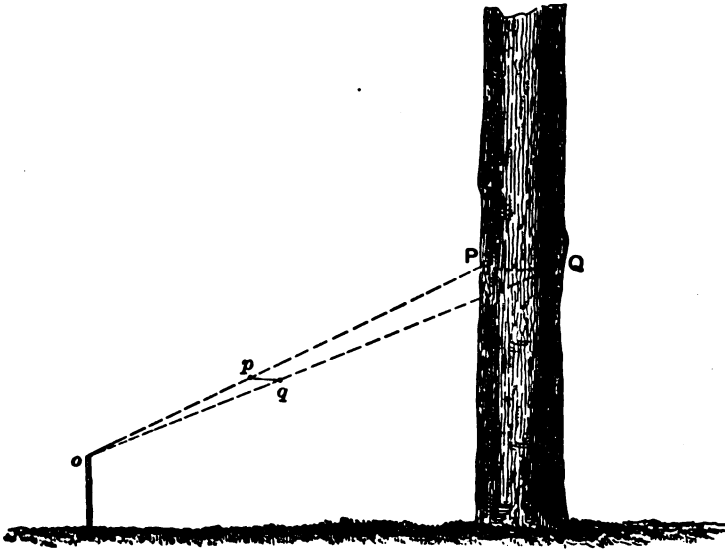

FIG. 28.

until the two objective plates exactly enclose the trunk of the tree at the required point, and the distance between the metal plates is read on the diameter scale. The instrument is then turned over and used as a height measure. The oblique distance from the eye to the observed point on the tree is determined by means of the scale on the pendulum. The desired diameter is then obtained by the formula: diameter equals oblique dis-

tance from eye to trunk multiplied by the distance between M and N on the instrument, divided by 10.

$D = \frac{tv}{10}$, where D is the desired diameter, t is the oblique distance from the eye to the tree where D is measured, and v is the distance between the objective plates M and N .

The theory of the instrument is shown by reference to Fig. 28. PQ is the desired diameter, pq the measured interval between the plates M and N on the instrument, and OP is the oblique distance from the eye to the tree. Two similar triangles are formed in which $PQ = \frac{OP}{Op} \times pq$.

The instrument is so constructed that the distance between the peep-sight and the objective plates M and N is exactly 5 inches. Twenty units of the diameter scale measure $\frac{5}{8}$ inch; each part being, therefore, $\frac{5}{128}$ of an inch. Substituting in the above formula, t for OP , $(v \times \frac{5}{128})$ for pq , and $\frac{5}{8}$ for Op :

$$\text{Diameter} = \frac{\frac{p.v.5}{128}}{\frac{5}{8}} = \frac{pv}{10}.$$

Unfortunately the instrument which is in the market is made in Austria and based on the Austrian foot and inches. The Austrian foot equals 1.04 English feet, the inches having the same ratio. In measuring the distance from the tree, therefore, it is necessary to use the following distances to conform to the Austrian measure.

Austrian.	English.
20 feet.....	20.8 feet
40 "	41.6 "
60 "	62.4 "
80 "	83.2 "
100 "	104 "

The results obtained are in Austrian inches, which may be translated into English inches by multiplying by 1.04.

With proper handling the Winkler instrument gives accurate results. The degree of accuracy falls off with the increase in the height above the ground of the point measured. There is danger of inaccuracy in dark woods where the edges of the tree are not sharply defined. The instrument is much better for general woods work than any other on the market because of its compactness and simplicity.

72. The Brandis Height Measure.—This instrument consists of a square tube about five and one-half inches long, with an

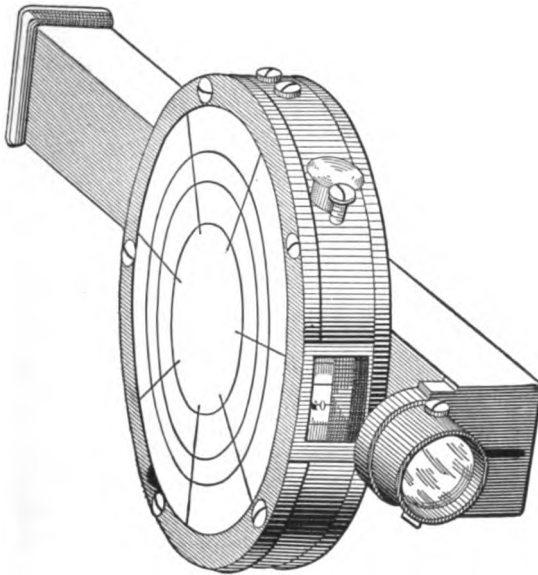

FIG. 29.—The Brandis Height Measure.

ocular slit at one end, and a single cross-wire at the other end as an objective. To the left-hand side of this tube is attached a weighted wheel about two and one-half inches in diameter, swinging between two pivots and enclosed in a circular metal

case. A small opening is cut in the periphery of the case, and directly opposite this opening a small lens is attached at the ocular end of the tube just to the left of the sighting-slit. The rim of the wheel, which can be seen through the opening in the case, is graduated in degrees, with plus and minus scales meeting at a zero-point, which, when the instrument is horizontal, is exactly opposite the slit. When the instrument is pointed upward or downward, the wheel remains stationary and the angles may be easily read through the lens attached to the eyepiece. On

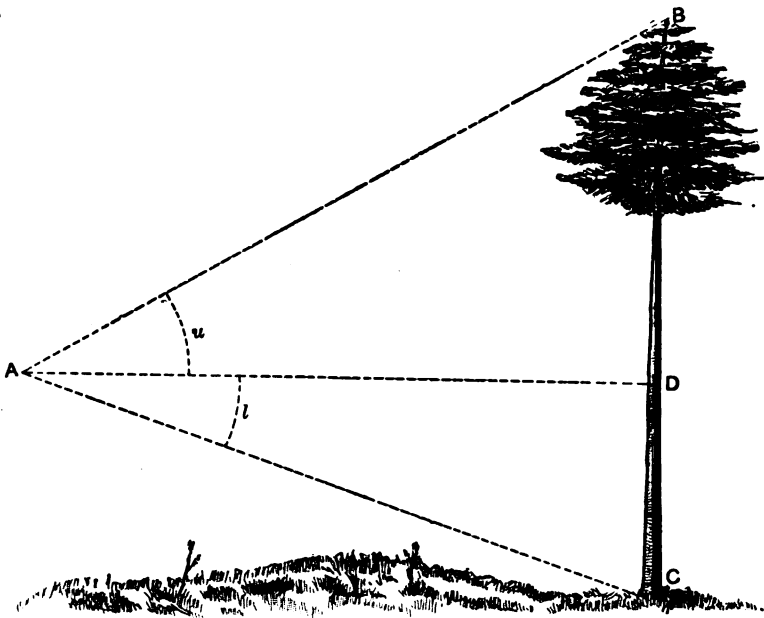

FIG. 30.

the side of the metal case is a retaining-spring, which clamps the wheel in any desired position, and which may be released by the pressure of a small button.

The theory of the instrument is illustrated in Fig. 30. AB represents the line of vision from the eye to the top of the tree; U the upper angle obtained by sighting to the tree top; AC the line

of vision to the base of the tree; and l the lower angle obtained by sighting to the base.

Then $BC:AC = \sin(u+l) : \sin b$

$$BC \times \sin b = AC \times \sin(u+l)$$

but $\sin b = \cos u$; substituting,

$$BC \times \cos u = AC \times \sin(u+l) \text{ or}$$

$$BC = \frac{AC \times \sin(u+l)}{\cos u}.$$

For convenience a table has been constructed which gives the value of the expression $\frac{\sin(u+l)}{\cos u}$ for all values of u and l which are likely to be required. This table accompanies the instrument. Most instruments have on the face of the metal case enclosing the wheel a small table giving the value of $20 \cos a$, $20 \sin a$, and $\tan a$ for different angles up to 30 degrees. This table enables one to compute heights when the distance from the tree is 20 meters, yards, or other units.

A very complete table is published in Calcutta, entitled Tables for Use with Brandis' Hyposometer, by F. B. Manson and H. H. Haines. Price in India, 8 annas.

To use the instrument, the distance from the tree is first measured, then the tip of the tree sighted through the instrument and the angle read from the wheel. Then the base of the tree is sighted and the corresponding reading taken. The value in the table corresponding to the upper and lower angles is then multiplied by the distance from the tree, for the desired height.

The height of the tree may also be obtained by reducing the degrees to tangents and multiplying by the distance, as explained in the next section. The Brandis height measure as an admirable clinometer for measuring slopes.

The chief value of the instrument lies in its compactness. The objections to it are that it does not give direct readings of height, but requires special computation and the use of a separate table; and that in dark woods it is difficult to read the graduations on the metal rim of the wheel. It may be purchased from Max Wolz, Bonn, Germany, price (in Germany), 22 marks.

73. Clinometer for Measuring Heights.—This instrument, shown in Fig. 31*a*, consists of a square panel of wood recessed to receive a metal disk and a glass which protects it. The disk has



FIG. 31.—Goulier's Clinometer.

a curved right-hand scale and a curved left-hand scale engraved upon it below its center. These scales meet at a zero-point, and correspond to each other in their graduations, which run outward in opposite directions from the zero-point to 100. The graduations of these scales represent percentages of angles instead of degrees of angles, as do the graduations of most clinometers. These two scales are swept by a pendulum ball, the lower half of which is beveled and brought to an edge having a central index mark. The upper end of the pendulum rod is formed into an eye through which a movable screw-stud passes, continu-

ing through the disk and panel and terminating at its rear end in a push-button. A spring secured to the back of the panel engages with the button and draws the head of the screw against the eye of the rod, thus holding the pendulum fixed. When the button is pushed inward, the pendulum is free to swing by gravity when the instrument is held in a vertical plane. The instrument is only about eight inches square and may be easily carried in one's pocket.

To use the instrument the observer sights along its upper edge to the top of the tree and releases the pendulum by pressing the push-button. When the pendulum comes to rest over the right-hand scale, the pressure on the push-button is removed, permitting the spring to hold the pendulum until the reading can be taken. The number now opposite the index mark is the percentage of the angle formed by a line running from the observer's eye to the top of the tree and a horizontal line running from him to its trunk. This percentage is the ratio between the height of the tree above the level of the observer's eye and the horizontal distance from the observer to the tree. This value is multiplied by the horizontal distance from the observer to the tree, and the result is the height of the tree above the level of the observer's eye. The observer then sights the instrument to the base of the tree, operates it as before, takes the reading from the left-hand scale, multiplies the value thus secured by the horizontal distance from him to the tree, and adds this result to that previously obtained, for the total height of the tree. These computations may be greatly simplified by taking all observations at a distance of 200 feet or 100 yards from the tree.

A more elaborate form of the instrument is furnished with a hinged cover having a mirror on its inner face, and with two sights located at the upper corners of the panel. (Fig. 31*b*.) The instrument is sometimes called Goulier's clinometer.

74. The Abney Hand Level and Clinometer.—This instrument (shown in Fig. 32) is a telescoping surveyor's hand-level of ordinary construction, except that its spirit-tube is located above

instead of in its main tube, which, however, contains the usual inclined steel mirror and sighting cross-wire.

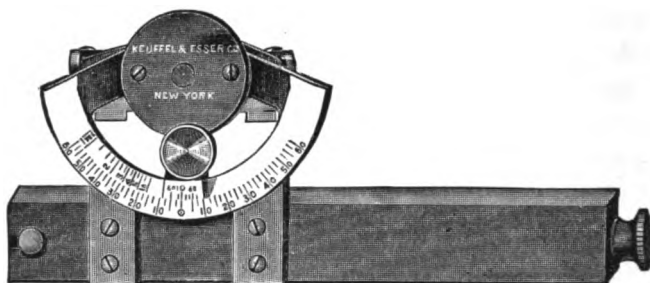

FIG. 32.—The Abney Hand Level and Clinometer.

Combined with the hand-level is a clinometer comprising a plate screwed to one side of the main tube of the hand-level and having engraved upon it a curved right-hand scale and a curved left-hand scale. These scales are struck from the same center and meet at a zero-point, from which they are graduated outward in degrees to 90. A measuring-arm, with a spatulate lower end beveled to receive vernier graduations, sweeps these scales. This arm is carried by a short shaft journaled in the upper edge of the plate and concentric with the two curved scales. The outer end of the shaft is furnished with a knurled hand-wheel, by which the clinometer is operated. The inner end of the shaft carries a frame which supports the tubular case containing the spirit-tube of the hand-level. The center of the case is cut away to show the bubble in the tube. On the extreme inner end of the shaft is a jam for setting the instrument, which, when turned inward, holds the shaft against turning. The measuring-arm and frame are rigid with the shaft. The case stands at a right angle to the measuring-arm, so that when the arm is placed at the zero-point of the two scales the case will be exactly parallel to the longitudinal axis of the hand-level.

Immediately below the exposed portion of the spirit-tube a slot is cut in the top of the main tube. A small mirror is fixed

at an angle inside the main tube directly underneath the slot. This mirror is so narrow and is placed so close to the side of the main tube that it does not obstruct the line of vision through the tube. The observer can thus see at the same time the cross-wires at the objective and the reflection in the mirror of the spirit-bubble.

In measuring the height of a tree the observer sights the instrument at the tip and turns the hand-wheel until the bubble shows that the case is level. The measuring-arm, which swings with the case, then indicates upon the right-hand scale in degrees an angle formed by a line running from the observer's eye to the top of the tree and a horizontal line extending from his eye to the trunk of the tree. He then consults a table of natural tangents, which gives him the value of the angle secured, expressed as its tangent or percentage. The tangent or percentage of this angle is multiplied by the horizontal distance from the observer's eye. He then sights to the base of the tree, and in the same manner ascertains the angle formed by a horizontal line running from him to the tree and a line running from his eye to the base of the tree. He now consults his table again for the value of this angle expressed as its tangent or percentage, and multiplies this value by his horizontal distance from the tree, which gives the height of the tree from the ground to the level of his eye. The figures thus secured are added together, giving the total height of the tree.

The scales of the instrument are sometimes graduated in tangents or percentages of angles instead of in degrees, in which case the table of tangents is not needed.

75. Other Height Measures.—Below are listed those other instruments which, by reason of cost, rarity, or serious disadvantages for practical use, seem to the author unlikely to be used in the United States. Students who may wish to make a special study of these instruments are recommended to consult the German books on Forest Mensuration, notably Müller's *Holzmesskunde*.

1. *Rueprecht's Height Measure*. Sold by A. Rueprecht, Vienna, Favoritenstrasse 25. Price 50 Crowns.
2. *Havlick's Staff Height Measure*. Sold by Gebr. Fromme, Vienna. Price 32 Crowns.
3. *Havlick's Hand Height Measure*. Sold by Gebr. Fromme, Vienna. Price 9 Crowns.
4. *Fricke's Nasenkreuz Height Measure*. Sold by Mechaniker Fentzloff, Hann.-Münden. Price 1.50 Marks.
5. *Stötzer's Height Measure*. Sold by E. Bischoff, Meiningen. Price 40 Marks.
6. *Ed. Heyer's Height Measure*. Sold by W. Spörhase, Giessen. Price 90 Marks.
7. *Trümbach's Height Measure*. Sold by Trümbach, Kgl. Bayr. Forstamtsass't, Obernburg a. M. Price 90 Marks.
8. *The Omnimeter*. Sold by Keuffel & Esser Co., N. Y. Price \$15.
9. *Bose's Height Measure*. Sold by Mechaniker Weingarten, Darmstadt, Germany. Price 6 Marks.
10. *Mayer's Height Measure*. Sold by L. Tesdorpf, Stuttgart. Price 45 Marks.
11. *Tiemann's Height Measure*. Must be made to order. Keuffel & Esser Co., N. Y. Price about \$50.

The dendrometers described in section 78 may all be used as height measures.

76. General Directions for the Measurement of Heights of Trees.—It is important to select for observation a station whence both the tip and the base of the tree may be distinctly seen. The tip of a coniferous tree is easily distinguished; but on a hardwood with a round top it is often difficult to distinguish the true tip from a side branch. If one should mistake a side branch on the near side for the tip, the measured height would be too large. The true tip may usually be seen by standing at some distance from the tree. The general rule is to choose an observation station at a distance approximately equal to the height of the tree; or if this is impractical, at a greater rather than a less dis-

tance. On a slope one should stand above rather than below the base of the tree. It is often difficult to distinguish the true base of a tree on account of brush, grass, or other obstacles. It is necessary to get a clear vision to the base; and if it cannot then be easily seen, a handkerchief or some other bright object may be used as a distinct point for sighting.

If a tree is leaning, one should choose a position in a line perpendicular to the vertical plane of the tree. The result of the measurement is then the distance from the ground to the tip of the tree and not the length of the tree itself. To determine the exact length of the stem of a leaning tree one would have to calculate the degree of inclination and from this reckon by trigonometry the true length. The object of taking a position at right angles to the direction of inclination is to avoid a possible mistake in measuring the distance from the tree. If one were in line with the lean of the tree and measured the exact distance to the base a false result would be obtained.

With most instruments the horizontal distance from the observer to the tree is required. In the case of the Klaussner hypsometer the oblique distance from the eye to the base of the tree and not the horizontal distance is measured. In all cases the distance should be measured, not paced.

In using the Klaussner instrument a beginner sometimes has difficulty with a leaning tree whose tip is not in vertical line with the base. The best plan is to sight to an imaginary point on a level with the true tip. If the instrument were perfectly leveled it would be possible first to take an observation to the base of the tree and then to turn the instrument enough to sight the tip. There is, however, no way of leveling the Klaussner height measure, and therefore the first method is the best.

77. Choice of a Height Measure.—Inasmuch as the choice of two equally good instruments depends on individual taste, opinions differ among foresters as to the best height measure. In the opinion of the author the Klaussner height measure is the best

of the small instruments for accurate scientific work. For general forest work where accuracy is desirable, but great precision is not necessary, the Faustmann height measure gives the most satisfactory results.

78. The Use of Dendrometers.—A considerable number of instruments have been manufactured for measuring the diameter of standing trees at different points. Several of these instruments are accurate, and may be used to great advantage in scientific work. They will probably not be much used in general forest work, for the following reasons: first, a good instrument is rather expensive; second, most dendrometers are delicate and easily thrown out of adjustment; third, as a rule they are rather large and cumbersome to carry, in addition to requiring a tripod; fourth, an observation, if properly made, is time-consuming; fifth, only the diameter outside the bark can be measured directly, the inside measurement being that usually required.

The dendrometer of Winkler described in section 71 is, in the judgment of the author, the best instrument for foresters from the standpoint of simplicity of construction, compactness, rapidity of measurement, and cost.

The Wimminaur dendrometer has been recommended by several American authors. It is, however, much more expensive than the Winkler instrument, and, on account of the delicate construction of certain parts, is less adapted to rough forest work. It may be purchased from W. Spörhase, Giessen, Germany, for about 75 marks.

The best instruments for purely scientific work are those of Joseph Friedrich, head of the experiment station at Maria-brunn, Austria, and of A. R. von Guttenberg, of the forest school in Vienna. These are instruments of great precision, and may be used in taking periodic measurements in studying diameter growth. They have to be made to order, and are therefore very expensive. Other dendrometers are: Peltzman's dendrometer, which can be secured from Gebr. Fromme, Vienna, price in Vienna 80 crowns; Starke's dendrometer, sold by Starke & Kam-

merer, Vienna; Sanlville's dendrometer, sold by Neuhofer & Sohn, Vienna, price 70 crowns. A special attachment for measuring diameters is made for the Klausner height measure.

For a detailed discussion of the different dendrometers, see Müller's *Holzmesskunde*.

CHAPTER XI.

DETERMINATION OF THE CONTENTS OF STANDING TREES.

79. Estimate by the Eye.—Persons who have constant practice in measuring logs and trees are able to estimate the contents of standing trees by a mere superficial inspection. Practiced timber cruisers attain an astonishing degree of accuracy in such estimates. The estimating of contents of trees at a glance is possible only by a trained eye. The inexperienced cruiser or one who is estimating an unfamiliar species must calculate the contents of standing trees from measured or estimated diameters and by the use of a log rule. It is necessary first to determine the lengths of the logs; then the diameter inside the bark at the top of each log.

The scale of each log is obtained from a log rule and the results for the different logs added together for the total scale of the tree. This method involves the ability to estimate diameters at different points up the tree and involves also a knowledge of the thickness of the bark, which varies at different points. For one not practiced in estimating diameters, a good method is to use a light 10-foot pole, attaching across one end a small stick marked off in inches by prominent notches. An assistant holds the pole against the trunk with the cross-stick at the point where the top of the first log would come. The diameter can be determined very accurately from the notched rule. From a diameter measurement at the base, taken with calipers, and another at the top of the first log obtained as just explained, it is possible

to estimate by comparison the diameters at the tops of the other logs. The average thickness of the bark at different heights must be allowed for. After one has taken a few measurements of bark on felled trees, it is possible to estimate fairly well by its general appearance the thickness of bark on standing trees. After sufficient practice in estimating diameters, the 10-foot pole may be discarded.

This method of determining contents works extremely well with trees having not over three or four logs. The butt log, since it has the largest scale, requires the most accurate estimate. If the contents of this log is correctly determined, a slight error in estimating the diameters of the others will not materially affect the total scale; except, of course, in tall trees with more than four logs. Naturally the work of estimating the diameters can be done more accurately with a good dendrometer. The time consumed in using a dendrometer, however, is so great that the method just described is more applicable to our conditions.

One method often used is to estimate the length of the merchantable portion of the tree, then estimate its top and base diameters, average these diameters, and determine the contents by the Doyle rule. If the length of the merchantable portion of a tree is 40 feet, the top diameter 6 inches, and the base diameter 14 inches, the average diameter would be assumed to be 10 inches, and the volume of the log would be, by the Doyle rule, 90 board-feet.

A number of rules of thumb are in existence for estimating the number of board-feet in standing trees. The following is a good illustration:

Subtract 60 from the square of the estimated diameter at the middle of the merchantable length of the tree, multiply by 0.8, and the result is the contents in board-feet of the average log in the tree; multiply by the number of 16-foot logs for the total scale.

A rule of thumb proposed by Dr. Schenck for estimating tall

sound trees by the Doyle rule is: to square the diameter, breast-high, multiply by 3, and divide the result by 2.

Still another rough method of Dr. Schenck is as follows: Assuming that the tree is to be cut into 16-foot logs and the taper is 2 inches per log, multiply the breast-height diameter of the butt log inside bark, by the number of logs, and multiply the result by the same diameter less 12.

A quick and fairly accurate method of estimating the volume of white pine in cubic feet is as follows:

Square the breast-height diameter (in feet) and multiply by 30. The rule gives excellent results for trees 10 to 14 inches in diameter and 80 feet high, 16 to 20 inches by 85 feet, 22 to 28 inches by 90 feet, and 30 to 36 inches by 95 feet. For other heights add or subtract for each 5 feet of length 6% for trees 10 to 20 inches, 5.5% for trees 22 to 28 inches, and 5% for trees 30 to 36 inches in diameter. Suppose, for example, a tree is 18 inches in diameter and 90 feet high, the rule would be: Square 1.5, multiply by 30, and increase the result by 5.5%, or

$$(1.5)^2 \times 30 + 5.5\% = 71.2 \text{ cubic feet.}$$

The volume table in the Appendix gives 71.9 cubic feet for such a tree.

A similar rule* is used in Germany to obtain the volume of standing trees in cubic meters, as follows: Square the diameter, breast-high, in centimeters, and divide by 1000. The rule holds good for pine 30 meters high, beech, oak, and spruce 26 meters high, and fir 25 meters high. For other heights add or subtract the following amounts for each meter of length, according as the tree is taller or shorter than the above heights:

Pine,	add 3%,	subtract 3%.
Beech,	“ 5%	“ 5%.
Spruce,	“ 3%	“ 4%.
Fir,	“ 3%	“ 4%.

* Called Denzin's method.

80. Estimate of the Contents of Standing Trees by Volume Tables and Form Factors.—Volume tables are used by foresters in this country more extensively than any other method of estimating the contents of standing trees. In Europe the method of form factors, as well as that of volume tables, is used. These methods are described in the next chapters.

81. Rough Method of Estimating the Cubic Contents of Standing Trees.—The cubic contents of the stem of a tree may roughly be obtained from the measured diameter at breast-height by the formula

$$V = \frac{BH}{2},$$

in which V is the volume, B the area at breast-height, and H the height. By reference to page 88, it will be seen that this is formula No. 3 for cubing a paraboloid.

82. Hossfeldt's Method.—On page 94 it was shown that a log may be cubed by the formula,

$$V = (3B_{\frac{1}{3}} + b) \frac{h}{4},$$

in which V is the volume, $B_{\frac{1}{3}}$ the sectional area at one-third the distance from the butt, b the sectional area at the top, and h the length of the log. In case of an entire stem b is 0, and the formula becomes

$$V = \frac{3}{4} B_{\frac{1}{3}} \times h.$$

To determine the cubic contents of a standing tree, the length of the stem above the probable stump is measured with a height measure, and the diameter at $\frac{1}{3}$ this length is estimated or is measured with a dendrometer. These measurements furnish data for the application of the Hossfeldt formula.

83. Pressler's Method.—In 1855, G. Pressler, a professor in the Forest School in Tharandt, devised the following formula for cubing a standing tree:

$$V = \frac{2}{3} B \left(H + \frac{M}{2} \right),$$

in which V is the volume of the tree, B is the sectional area measured just above the butt swelling, H is the distance from the stump to the point on the stem where the diameter is exactly one-half that measured at the butt, and M is the distance from the stump to the point where B is measured. Ordinarily B is taken at breast-height. The stem of a tree is cubed as two sections, (1) the portion above the point where the diameter is taken, considered as a paraboloid or a cone; (2) the portion between the stump and the point of diameter measurement, considered as a cylinder with a diameter equal to that at the upper end of the section. The stump and branches are disregarded. The main part of the stem is cubed by the formula,

$$V = \frac{2}{3}B \times h,$$

in which h is the distance from B to the one-half diameter-point. This holds good for both the paraboloid and the cone, as may be seen in the following demonstration:

In a paraboloid the point at which the diameter is $\frac{1}{2}$ that at the base, is $\frac{3}{4}$ the altitude. If this distance is h , the total altitude H , the basal area B , then

$$h = \frac{3}{4}H, \quad \text{and} \quad H = \frac{4}{3}h$$

Substituting in the formula

$$V = \frac{BH}{2}, \quad \text{then} \quad V = \frac{B}{2} \times \frac{4}{3}h = \frac{2}{3}Bh.$$

The same process of reasoning will show the formula correct also for the cone.

The lower part of the tree is cubed as a cylinder by the formula,

$$V = B M.$$

The volume of the whole stem is then

$$\begin{aligned} V &= \frac{2}{3}Bh + BM \\ &= \frac{2}{3}B \left(H + \frac{M}{2} \right). \end{aligned}$$

A dendrometer may be used to determine the point where the diameter is one-half that at the base. Pressler devised a special instrument for this purpose, consisting of a small paste-board telescope with an eyepiece at one end and with two pins or screws at right angles to the axis of the instrument at the other end. In use the telescope is first closed and the tree is sighted where the base diameter is to be taken. The pins or screws are adjusted so that the stem appears to occupy the space between the points. The instrument is then drawn out to twice its former length, and sighted up and down the stem to find the point exactly fitting between the pins. The diameter of the tree at this point is one-half that at the point first measured.

CHAPTER XII.

VOLUME TABLES.

84. Definition of Volume Tables.—Volume tables show the average contents of standing trees of different sizes. They may be made for any desired unit—the cubic foot, board foot, standard, cord, or cubic meter—or they may show the contents of trees in ties, poles, shingles, or other product. They are used to estimate the yield of wood and timber standing on specified tracts. Volume tables are intended only for estimating a large number of trees. Compiled from the average of a number of measurements, they are necessarily inaccurate as applied to a single tree. The volumes of individual trees of the same species and same dimensions may vary 20 percent. or more. On the other hand, the average volume of a large number of trees of the same species, having the same height and diameter and growing under the same conditions, is very uniform; and tables showing the average volumes of a large number of felled trees give satisfactory results in estimating the contents of a large number of standing trees.

Volume tables may be local or general. Local volume tables are based on the measurement of trees growing in a restricted locality and usually under specified conditions of mixture, density, etc. General volume tables are based on the average volume of trees growing in a variety of conditions over a large region. In Germany general volume tables are usually made. In this country the forests are so irregular in age, density, and form that

local volume tables are the rule; and often there must be separate tables for areas as small as townships or counties. The best rule is to make separate tables at least for every forest region.

85. Volume Tables for Trees of Different Diameters.—The simplest and most convenient volume tables show the average contents of trees of different diameters. These are the tables in most common use in estimating the merchantable contents of standing timber. The total contents of trees of any given diameter are computed by multiplying the number of trees by the average volume given in the volume table for that diameter. (See page 219.)

The tables are based on the measurement and computation of volume of a large number of felled trees. These data are usually secured where lumbering is in progress. A crew of two or three men follow the cutters and measure the trees as they are felled. If the investigation includes only the preparation of volume tables, the following measurements are usually taken on each tree: diameter at breast-height; diameter at each cross-section, inside and outside the bark; length of each log; length of the top above last cut, and height of stump, giving total height; length of crown, and width of crown. With these measurements, the merchantable or full contents of the stem, with and without bark, may be computed. The measurements of the length and width of crown serve as an excellent description of the tree. In addition, it is usually desirable to add a descriptive note regarding the form of the trunk, soundness, general thrift, approximate age, the form of the stand, the trees in mixture, and the soil and situation. Where a volume table is constructed for diameters alone, a full description of the tree and forest is not essential.

A crew of three men is most effective for work in collecting measurements of volume. One man selects the trees, directs the work, and records the measurements. The others do the measuring. The proper equipment of such a crew is a pair of calipers, tape, scale rule, and record book or tally-sheets.

Before undertaking the field work of collecting material for

volume tables, it is desirable to examine the forest where the tables are to be used in estimating, in order to determine what type of trees ought to be measured. It is then decided how many trees to fell and measure, and in general how they should be distributed among the different diameters. Ordinarily the aim is to measure at least 1000 trees as a basis for volume tables; but where the timber is very uniform, as with most conifers, 500 trees give exceedingly good results. If the tables are to be used in careful cruising, at least 500 trees should be measured. In reconnaissance work and rough cruising, or where the trees are extremely regular in form, 100 trees may suffice.

Care is required in the selection of the trees for measurement. It is the rule to measure only sound trees, because volume tables show the full contents of sound trees. It might appear that the tables would be more practical if based on average trees, including those partially defective. But a table made up in this way would be extremely unreliable, for it is well known that the defects of trees differ greatly in different situations; so that a table based partly on defective trees would be useless in estimating trees whose defects are different from those of the trees observed in its construction. Again, any such defect as injury by fire, insects disease, wind, or ice, would entirely vitiate a table constructed for trees showing another defect than the particular one in question; whereas a table based on sound trees may be reduced in any given case, just as log rules are reduced for unsoundness in logs.

Care should be exercised to select for measurement trees representative in form. The temptation usually is to measure only the best trees; but it must be remembered that the figures will represent the average tree of each diameter, regardless of difference in the number of logs, total height, or tree class. Therefore each tree should be a good representative of its class, and normal in height, size of crown, form of trunk, etc. Different classes of trees should be represented about as they occur in the forest; that is, there should be about the same percentage of

one-log trees, two-log trees, three-log trees, etc., as ordinarily occur in the particular forest under observation. This point is to be especially observed when the number of trees measured is limited. If 1000 trees are to be measured, it is ordinarily sufficient to measure trees as they are cut by the lumbermen, taking care that the diameters are well distributed and that the trees are not abnormal. Abnormal trees are those with forked trunks, those with swollen butts, and diseased or distorted trees.

The first work of computation is the calculation of the volume of each tree measured. The work can be done most rapidly by two persons, one handling the data collected in the field and the other the log tables, tables of areas, or other tables necessary in determining the contents of the logs in the unit chosen. The computing work may, with economy of time and mental effort, be divided between the two.

The trees measured are grouped according to breast-height diameters in inch classes. Thus the 6-inch class comprises all trees with a diameter between 5.6 and 6.5 inches. In judging the diameter class the five-tenths goes to the lower rather than the higher number; that is, a tree 12.5 inches in diameter is counted as a 12-inch tree, not a 13-inch tree. The volumes of all trees in a single-diameter class are averaged together and the exact average diameter also determined, the last being usually not a whole inch, but a few tenths, above or below the whole number. The data may then be arranged in five columns, as in the table on page 162. The first column shows the inch-diameter classes, the second column the exact average diameters of the trees in each diameter class, the third column the number of trees used, the fourth column the average volume of the trees in each diameter class, and the fifth column the results of the fourth column made regular by graphic interpolation. To construct the curve used in obtaining the values in column five, the volumes from column four are plotted on cross-section paper as ordinates, with the average diameters in column two as abscissæ. The values in column three show what points are to receive most em-

phasis in drawing the curve. For the final results in column five, the values for the whole inches are read from the curve.

CHESTNUT—VOLUME TABLE FOR TREES OF DIFFERENT DIAMETERS.

BASED ON THE MEASUREMENT OF 101 TREES AT MILFORD, PA.

Diameter Class, Breast-high, Inches.	Average Diameter of Trees Measured, Breast-high, Inches.	Number of Trees Measured.	Average Volume of Trees Measured, Cubic Feet.	Average Volume Results of Column 4 Evened Off by Curve, Cubic Feet.
6	6.25	2	4.7	4.5
7	7	10	5.4	5.4
8	8.1	13	7.2	7
9	9	16	9.4	9.3
10	10	15	11.7	11.7
11	11	14	14.9	14.4
12	12	18	16.2	17.1
13	12.9	9	20.2	20.2
14	14.1	3	23.6	23.4
15	14.9	1	27	27

Another method of averaging together the volumes for different diameters is as follows:

The volumes of all trees are plotted on cross-section paper as ordinates, the abscissæ being the diameters breast-high. After the volumes of all trees have been plotted, an average curve is drawn through the points. From this curve are read the average volumes for the different diameters.

Volume tables for trees of different diameters give very satisfactory results in cruising, particularly when the tables have been prepared for special conditions. They are not, however, applicable to forests where the conditions of growth differ from those prevailing where the data were gathered. If, for example, the tables were based largely on tall trees, they could not be used where the trees are, on an average, shorter. This objection is largely obviated by making local tables for restricted areas, on which the general conditions for growth are fairly uniform.

Volume tables for trees grouped by diameters alone are designed primarily for commercial estimating in board measure.

A further grouping of the trees is necessary for very close determination of volume, as described in the succeeding sections.

86. Volume Tables for Trees Grouped by Diameter and Number of Logs.—In the method just described all trees are averaged by diameters regardless of height or length of merchantable timber. Thus one-log trees are averaged with three-log trees, or even five-log trees, of the same diameter. In order to secure greater accuracy, volume tables based on trees grouped by diameters and number of logs were devised. Such tables are in actual use by cruisers. They are used in tall timber where a standard log-length—as, for example, 16 feet—may be used in the estimate of the number of logs.

To construct a volume table for trees grouped by diameters and number of logs, a large number of felled trees are measured and their volumes computed as described for the previous method. The trees having the same number of logs are then grouped together, and the average volumes of one-log trees of different diameters are determined, then of two-log, three-log trees, etc. If the volumes do not increase regularly with increase of diameters, the irregularities are evened off by graphic interpolation. The results are expressed in a form like the following:

VOLUME TABLE FOR TREES OF DIFFERENT DIAMETERS AND NUMBER OF LOGS.

LENGTH OF STANDARD LOG FEET.
(Based on the Measurement of Trees.)

Diameter, Breast-high, Inches.	Volume of One-log Trees, Board Feet.	Volume of Two-log Trees, Board Feet.	Volume of Three-log Trees, Board Feet.	Volume of Four-log Trees, Board Feet.

The objection to this method is that trees are not always cut into logs of the same length. Even with very tall trees it is seldom that all the logs are the same length. A tall white pine may

for example, yield three-sixteens, and one twelve. If the volume tables are based on sixteen-foot logs, an inaccurate estimate would result if this were classed as a four-log tree. These tables are, therefore, not much more accurate than those first described.

87. Volume Tables for Trees of Different Diameters and Merchantable Lengths.—On account of the defects of the previous method, it has been proposed to base volume tables on trees grouped by merchantable length as well as by diameter. The length classes should be such as would be actually used in practice. When short logs are used, the merchantable length of a given tree would be the sum of the log lengths. In this case the length classes would have to correspond to all the possible combinations of short logs. Two-foot classes would meet this requirement, and would also be small enough for the conditions where the whole merchantable part of the tree is taken out as one log. To construct such a table, the measurements of felled trees are first obtained in the ordinary way. The computed volumes are grouped by the diameters and merchantable lengths of the trees, each length class comprising two feet. A preliminary table of averages is made, giving the average volume of trees of different diameters with a merchantable length of 10 feet, those with a merchantable length of 12 feet, those with 14, 16, 18, 20, 22 feet, and so on. Under ordinary circumstances it will be found that this table has irregularities not only in the vertical columns, but also in the horizontal lines. These irregularities are then evened off by a series of harmonized curves. The final table may be expressed in a form like that shown on page 165.

As far as the author is informed, no such volume tables have been made. They should, however, yield very accurate results, although more difficult in application than the volume tables based on diameters alone. Their use in estimating stands is described on page 222.

88. Volume Tables for Trees of Different Diameters and Tree Classes.—These are designed for use where the trees have grown under varying conditions of density and form of the stand,

VOLUME TABLE FOR TREES OF DIFFERENT DIAMETERS AND MERCHANTABLE LENGTHS.

BASED ON THE MEASUREMENT OF TREES.

Diameter, Breast-high, Inches.	Merchantable Length in Feet.								
	10	12	14	16	18	20	24	28	30
	Board Feet.								

as in very irregular forests. Such tables are particularly useful in estimating cord-wood in second-growth hardwood forests. The author has found that volume tables based on diameter alone are not accurate for cordwood work, when large branches are merchantable, a table based on merchantable length is out of the question. On the other hand, a table which gives separately the volume of the trees with large crowns, those with medium crowns, etc., yields very good results. No rules can be laid down for the formation of classes. Under some circumstances, it might be desirable to make three classes—dominant, intermediate, and suppressed trees. Elsewhere a grouping of trees with large crowns, medium crowns, or small crowns would be proper. In second-growth hardwoods the following classification will be found to be useful:

1. Trees in the open.
2. Large-crowned forest trees (maximum in stand).
3. Trees in crowded stand, crowns narrow and about 15-20 percent of the length of stem.
4. Overtopped and partially suppressed trees.
5. Badly suppressed trees.

In selecting the trees for volume measurement, much greater stress is placed on the description of the trees than with the other kind of volume tables. It is particularly important to describe

the conditions of density, form of surrounding stand, and shape and dimensions of the crown, because these are the factors which determine the class to which a particular tree is assigned. After computing the contents of the trees, they are separated into classes, and then for each class a table is constructed in the ordinary manner, showing the volume of trees of different diameters. These separate tables are then combined in the following form:

VOLUME TABLE FOR TREES OF DIFFERENT DIAMETERS AND TREE CLASSES.

BASED ON THE MEASUREMENT OF TREES.

Diameter Breast-high, Inches.	Tree Class.				
	I.	II.	III.	IV.	V.
	Cords.				

89. Volume Tables for Trees of Different Diameters and Heights.—These are usually considered the most accurate kind of volume tables. The European volume tables, which are used with satisfactory results, even where considerable accuracy is required, are based on this principle. In Europe, however, the ordinary volume tables are used in estimating regular forests and separate tables are made for different age classes. Even when used in very irregular stands, where the trees differ largely in age and development of crown, they are more accurate than volume tables based on diameter alone. They are probably not as accurate as those based on diameter and merchantable length, because the merchantable length is a better index of the volume of a tree of a given diameter than the total height.

Volume tables based on diameter and height have been constructed for several species in this country and used in practical work of estimating. They give good results with trees of

regular form like the pines and spruces, but with the hardwoods they are not entirely satisfactory unless separate tables are made for different tree classes.

The construction of volume tables for trees of different diameters and heights is based on the measurement and computation of volume of a large number of felled trees. European volume tables are based on tables of form factors. In this country a number of tables have been constructed by averaging together directly the volumes of the measured trees, grouped by diameters and height classes. The procedure in this method is as follows: The computed volumes of the measured trees are grouped by inch diameters and five-foot height classes. Figures of each diameter and height class are then averaged together and the results compared in a preliminary table. This preliminary table, even if based on a very large number of measurements, usually is irregular in both the horizontal and vertical directions. All values are then evened off by a series of harmonized curves. The final form of the table is illustrated by the following example:

CHESTNUT—VOLUME TABLE FOR TREES OF DIFFERENT DIAMETERS AND HEIGHTS.

BASED ON 99 TREES MEASURED AT MILFORD, PA.

Diameter, Breast-high, Inches.	Height in Feet.				
	40	45	50	55	60
	Merchantable Cubic Feet.				
6	3.9	4.2	4.6		
7	4.8	5.1	5.7		
8	6.2	6.6	7.3	8.1	
9	7.8	8.3	9.0	10.0	
10	9.7	10.2	11.1	12.2	
11	12.0	12.6	13.6	14.8	16.3
12	15.1	16.1	17.4	18.9
13	17.8	18.9	20.2	21.7
14	20.9	22.0	23.4	25.0
15	28.8

Another method, and the one most commonly used in Europe, is first to make a table of form factors and then convert this into a volume table by multiplying each value by the product of the corresponding height and basal area. The conversion of a form-factor table into a volume table should present no difficulty to the student after reading the next chapter, which describes the theory and use of form factors.

This last method is applicable only to cubic measure. Often it is desirable to make a volume table in cubic feet as a foundation for a table in some other unit. One of the best ways, from the standpoint of accuracy, of making a volume table for merchantable timber is first to construct a table of cubic contents of the entire stems of trees and then reduce this to a table of merchantable contents. It is a good method because the contents of whole stems do not vary so much as the merchantable volume and a table of averages may be constructed with less interpolation. A table showing the ratio of merchantable to total contents may then be constructed and applied to the first volume table to reduce the values to merchantable terms.

Suppose that a table of cubic contents of the stems of white pine has been constructed, like that in the Appendix, and one wishes to convert it to board feet, the procedure is as follows: The volume of each of the trees measured is computed in cubic feet and also in board feet and the ratio between the two determined. The cubic volume in each tree is multiplied by 12 and the board feet divided by this product. The result represents an artificial but convenient ratio between the cubic and board feet of each tree. A table of factors is then constructed for trees grouped by diameters and heights or by diameters alone. Such a table was made by the author in constructing volume tables for white pine, and may be used as an illustration (see page 169).

The cubic volume table is then converted into board measure. Each value is multiplied by the factor in the table corresponding to the diameter, and the result multiplied by 12 in order to convert back to board feet.

RATIO BETWEEN THE BOARD CONTENTS AND TOTAL
VOLUME OF WHITE PINE.

Diameter, Breast-high, Inches.	Board Feet Reduced to Cubic Feet in Percentage of the Total Volume of Wood and Bark.	Diameter, Breast-high, Inches.	Board Feet Reduced to Cubic Feet in Percentage of the Total Volume of Wood and Bark.	Diameter, Breast-high, Inches.	Board Feet Reduced to Cubic Feet in Percentage of the Total Volume of Wood and Bark.
10	12	22	35	34	46
12	18	24	38	36	47
14	23	26	40	38	48
16	26	28	42	40	49
18	29	30	44		
20	32	32	45		

90. Graded Volume Tables.—The volume tables described in the preceding pages give the contents of trees in a given unit, but they do not indicate the quality of the product. Graded volume tables show for trees of different sizes the amount of timber of different grades and enable the determination of the money value of standing trees better than the ordinary volume tables.

The U. S. Forest Service is at present studying the yield, in timber of different grades, of all the important trees. Already investigations of long-leaf pine, loblolly pine, yellow poplar, white oak, chestnut, ash, and other hardwoods in the South, and maple, birch, and beech in the Adirondacks, have been initiated. The results of such studies are expressed first as graded volume tables, and second as tables showing the money value of trees of different sizes.

The method of constructing a graded volume table is as follows: * A large number of trees are measured as soon as they are cut by the saw crews. The length and top diameter of each log are measured and a mark placed on the end. Each tree is given a number and each log in that tree an additional number or letter. Thus, for example, 576² indicates the second log

* From the Determination of Timber Values, by E. A. Braniff, Year book of the U. S. Dept. of Agriculture for 1904.

(counting from the butt) of tree 576. The logs are then sawed at the mill and their exact yield in graded lumber determined.

The measurements at the mill are taken in the following way: A man stands near the slab-carrier. As each piece of siding from a marked log is dropped on the rollers, the number of the log is chalked on it. When a siding has passed through the edger and trimmer, it is graded and measured and a record made of the log number, grade, and dimensions. These data for all boards cut from the marked logs enable the computation of the exact product in graded lumber of each log, and by combining the products of all logs having the same tree number, the total yield of each tree is computed. The data taken in the woods serve a check on the work at the mill.

When the volume of all the trees has been determined, the trees are grouped together by inch-diameter classes and the average contents of trees of each diameter computed. Any irregularities in the resulting table are evened off by curves.

The form of these tables is well illustrated by the Graded Volume Table for Yellow Birch as shown on page 171. This is the result of an investigation in the Adirondacks by the U. S. Forest Service.

This table shows the yield of choice grades of birch advancing rapidly with the growth of the tree. The choice grades are firsts and seconds red, and firsts and seconds. The amount of red birch in a tree under 18 inches in diameter is too small to consider. An 18-inch tree contained 2 board feet of this high-priced lumber, a 19-inch tree only 4 feet of it, a 20-inch tree 8 feet, but in a 21-inch tree the amount rose to 23 board feet, showing a gain of almost 200 percent. over the product of the previous diameter. The explanation for the exceptional increase is that the rules of the National Hardwood Lumber Association, under which the lumber was inspected, require red birch 4 or 5 inches wide to show one face all red; over 5 inches, one face must be not less than 75 percent red. Red birch is heart-wood, and it happens that the heart-wood is not wide enough to pass the

GRADED VOLUME TABLE FOR YELLOW BIRCH.

Diameter. Breast-high. Inches.	Firsts and Seconds Red. Bd. Ft.	Firsts and Seconds. Bd. Ft.	No. 1 Common. Bd. Ft.	Shipping Culls (No. 2 Common). Bd. Ft.	Mill Culls (No. 3 Common). Bd. Ft.	Sound 7" X 9" X 8' Ties. Bd. Ft. *	Total. Bd. Ft.	Number of Trees Talked.
13	3	5	6	20	25	59	7
14	7	7	7	37	37	95	16
15	11	10	8	41	55	125	23
16	16	12	8	38	72	146	32
17	22	14	8	35	84	163	32
18	2	28	17	9	36	94	186	57
19	4	36	20	10	45	102	217	50
20	8	44	24	11	55	108	250	39
21	23	54	28	13	65	114	297	40
22	26	66	31	15	74	119	331	46
23	36	78	33	16	82	118	363	25
24	48	86	36	18	88	112	388	37
25	62	92	38	19	93	104	408	30
26	81	97	42	20	98	96	434	24
27	101	103	47	22	106	91	470	28
28	116	110	53	22	118	86	505	16
29	128	120	59	23	134	81	545	4
30	139	132	64	24	155	74	588	12
31	150	144	68	25	180	52	619	4

* To obtain number of ties divide board feet in this column by 42.

severe inspection in considerable quantities in trees under 21 inches in diameter. The increase of red birch goes on steadily from the 21-inch to the highest diameters. The next best grade, firsts and seconds, not graded by color, is contained in practically all sizes of merchantable trees. The increase of this grade goes on steadily, but is greatest between 18-inch and 23-inch trees, because the inspection rules, which favor wide boards, show their greatest effect here. Narrow boards from small trees grade lower than wide boards from large trees.

When we compare the choice grades (firsts and seconds red, and firsts and seconds) with the common ones (No. 1 common, shipping culls, and mill culls) we find that the choice grades increase, on the whole, much more rapidly with the growth of the tree than do the latter. In the case of firsts and seconds red there was a rise between a 13-inch and a 31-inch tree from 0 to 150 feet, and in the case of firsts and seconds from 3 to 144

feet. Contrast this with No. 1 common, which rises from 5 to 68 feet; with shipping culls, which rise from 6 to 25 feet; and with mill culls, which rise from 20 to 180 feet, and the tendency of the better grades to outstrip the poor ones becomes apparent. The fact must not be overlooked, however, that a considerable amount of what would have made inferior grades went, in this instance, into railroad ties.

The table given on page 171 may be used to determine the money value of trees of different diameters. If the value of each grade of lumber is known, it is a simple matter to convert a graded volume table into a money value table. According to prices obtained from the Boston and New York markets for yellow birch, the table given above may be expressed as follows:

VALUE OF YELLOW BIRCH.

Diameter, Breast-high, Inches.	Graded Volume, Bd. Ft.	Value per Tree.	Value per 1000 Bd. Ft.	Diameter, Breast-high, Inches.	Graded Volume, Bd. Ft.	Value per Tree.	Value per 1000 Bd. Ft.
13	59	\$0.55	\$9.32	23	363	\$5.19	\$14.30
14	95	0.89	9.37	24	388	5.80	14.95
15	125	1.22	9.76	25	408	6.39	15.66
16	146	1.52	10.41	26	434	7.15	16.48
17	163	1.78	10.92	27	470	8.03	17.09
18	186	2.13	11.45	28	505	8.80	17.43
19	217	2.56	11.80	29	545	9.57	17.56
20	250	3.06	12.24	30	588	10.34	17.59
21	297	3.98	13.40	31	619	10.99	17.75
22	331	4.51	13.63				

This table illustrates how the value of trees increases with increase of diameter. Not only do the trees increase in value, but their value per thousand feet increases as they grow larger. These tables may be used not only to determine much more closely than ordinarily the value of timber land, but when combined with a knowledge of growth they enable an owner to determine what trees should be cut and what should be left to accumulate increment.

Graded volume tables must necessarily be made for restricted

regions or localities. The methods of manufacture differ not only in different localities, but also at different mills. The quality of the timber varies in different regions, due to differences in the character of the soil, exposure, and other silvical factors. Graded volume tables should be made, therefore, to apply to a specified set of conditions.

In the same way tables of timber values must be local in character, and in constructing them, one should consider the changes in price of the different grades. The graded volume tables now being made are based on diameter alone. It would, of course, be possible to make more elaborate tables for different tree classes, trees of different heights, etc. It is, however, probable that the present method will answer the present needs of forestry.

The principle of graded volume tables may be extended to comprise other products than lumber. Thus tables may be constructed to show the volume of chestnut trees of different diameters in ties of different grades, in posts, and in cord-wood.

Volume tables may also be made for poles. Thus it would be of great practical value to have tables showing the average length and top diameter of poles yielded by chestnut of different diameters, or the length and middle diameter of piles contained in pitch pine trees of different sizes.

CHAPTER XIII.

FORM FACTORS.

91. Definition of Form Factors.—The form factor of a tree is the ratio between its volume and that of a cylinder having the same diameter and height. Expressed mathematically,

$$F = \frac{V}{BH}, \text{ or } V = BHF,$$

in which F is the form factor, V the volume, B the basal area, and H the height of the tree. The form factor is, then, a reducing figure by which the volume of a cylinder having the same diameter and height as the tree must be multiplied to obtain the volume of the tree. Inasmuch as the tree has a smaller volume than the cylinder, this reducing figure is a fraction.

It is customary to distinguish between *breast-height form factor*, *absolute form factor*, and *normal form factor*. The breast-height form factor is obtained by the use, in the above formula, of the sectional area at breast-height; that is, the diameter of the cylinder to which the tree is compared is the same as the breast-height diameter of the tree, as shown in Fig. 33. The breast-height form factor is the one most commonly used, and in this book the term form factor will always mean breast-height form factor unless otherwise indicated.

If a tree is compared to a cylinder having a diameter equal to the diameter at the base of the tree, the *absolute form factor* results. According to the usual conception, the absolute form factor is based on a sectional area taken at the ground, as shown

in Fig. 34. If the volume used in the form-factor formula comprised only the portion of the tree above the stump, the sectional area would be taken at the stump in computing the absolute form factor. In the same way the absolute form factor

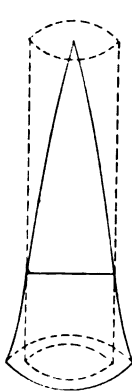

FIG. 33.

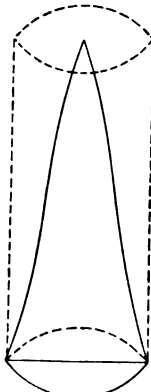

FIG. 34.

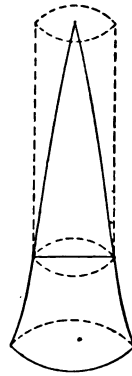

FIG. 35.

is sometimes used to compare the portion of the stem above breast-height with a cylinder having a diameter equal to the breast-height diameter and having a height equal to the height of the tree minus 4.5 feet (Fig. 35). In this case the portion below breast-height is disregarded or considered separately.

Still another kind of form factor is obtained when the basal area is determined not at a fixed distance from the ground, but always at a distance having a fixed ratio to the height of the tree. The resulting form factor is called the *normal* or *true form factor*.

A still further classification of form factors is usually made. If, in the form-factor formula, the merchantable volume of the tree is used, the form factor is called the *merchantable* or *timber form factor*. If the volume of the stem alone (including the top above merchantable wood) is used, the *stem form factor* is obtained. The *tree form factor* results when the entire volume of the tree, including branches, twigs, and all, is used in the formula. In this country only merchantable and stem form factors are used.

92. The Use of Form Factors.—Form factors are used to determine the contents of trees. If the basal area, height, and form factor of a tree are known, the volume is obtained by the formula $V=BHF$. Tables are constructed showing the average breast-height form factors of trees of different dimensions, for use in estimating the cubic contents of standing timber. Just as volume tables, form-factor tables are designed for use in estimating the volume of a large number of trees and not of a single tree. European foresters constantly use form-factor tables in estimating standing timber. Convenient tables for different species are published in pocket handbooks like the *Forst u. Jagd Kalendars* of Prussia, Bavaria, and Austria. In this country form factors will be used chiefly in scientific work, as a basis for volume tables in cubic feet and other units, and as a method of comparing the form of trees of different species and of the same species growing under different conditions. They will not be used much in estimating timber because it is just as easy to construct volume tables, which are much more convenient for practical use in the field.

93. Variations in the Value of Breast-height Form Factors.—The term “false” form factor is sometimes applied to the breast-height form factor because it is not a true expression of form. This is best illustrated by comparing the breast-height form factors of two perfect bodies (as, for example, two Apollonian paraboloids) which have different heights and different diameters. Inasmuch as the two bodies have the same geometric form, the form factors, if true expressions of form, should be the same. But in our illustration the breast-height form factor of the paraboloid with the greater height is the smaller. The reason for this is that the sectional areas are taken at the same distance from the ground, a point which in relation to total height is relatively higher on the shorter paraboloid. In consequence the volume of the cylinder to which the shorter paraboloid is compared is relatively smaller than in the case of the larger paraboloid, and the form factor is the larger. In

other words, the breast-height form factors of trees of exactly the same form decrease with the increase of height.

One would naturally conclude that tables of form factors would be constructed to show average values for trees of different heights without regard to the diameters. In fact such tables were made in Europe—as, for example, those of Dr. Koenig—for Spruce and Fir.* But when the form factors of trees are compared, it is found that they do not always vary by the height alone, but sometimes by both height and diameter and sometimes by diameter alone. The explanation of this lies in the fact that trees vary so much in form that the tendency of the form factors to decrease with increasing height is often counter-balanced.

Influence of Density on the Size of Form Factors.—The forms of trees are distinctly influenced by the character of the forest in which they grow. It is a matter of common observation that trees growing in the open are apt to be more tapering than those growing in dense forests. Expressed in another way, forest trees are full-boled and the stem or merchantable form factor of a forest tree is ordinarily greater than that of a tree growing in the open. On the other hand, very old trees which stand in the open frequently have a greater stem form factor than those in the forest.

In view of the variation in form factors due to differences in density of stands, it is desirable, particularly in this country where the forests are very irregular, to make separate form-factor tables for different tree classes. In 1864 the proposition was made by Dr. Koenig of Germany to make separate tables of form factors for the following classes of trees:

First-class trees in crowded stand, slim and with narrow crowns.

Second-class trees in stands of moderate density, more sturdy and wind-firm.

* *Hilftabellen der Forstmathematik*, by Dr. G. Koenig, 1864.

Third-class trees in rather open stands, with full crowns.

Fourth-class trees in open stands, with heavy crowns.

Fifth-class trees standing singly.

A similar classification is often desirable in this country. In much of our work, however, it may be better to make only three classes, as suggested for classifying trees in constructing volume tables (see page 165).

Influence of Situation on the Size of Form Factors.—It has been long a matter of controversy whether the average form factors of a given tree vary in different localities and in different classes of soil. Without question the form factors are somewhat influenced by the climate and by the character of the soil. Other factors, particularly density, are of much greater importance, and usually trees from different forest types and different classes of soil are averaged together in a single table. If the tree classes are kept separate, variations due to situations may be disregarded.

Influence of Age on the Size of Form Factors.—Old trees have more cylindrical trunks than young ones. It is a saying among foresters that when a tree carries its diameter well up into the crown and has a full bole, it is old. This fact would indicate that the form factors increase with age.

This is well illustrated in the case of the Norway spruce, whose stem form factor for trees 20 centimeters in diameter and over 90 years old is 0.559, but for trees under 90 years old and 20 centimeters in diameter is 0.534. Taking investigations of the different European trees as a whole we find no regular variation of stem form factors with age. This seems contradictory to the statement just made. But it is probable that only great differences in age affect the stem form factors and the trees used in the European investigations do not vary enough in age to be affected by this influence. Dr. Franz Baur of Germany proposes that separate tables of form factors be made for different age classes, each comprising 40 years. While it is a

matter of contention whether differences in age have much influence on the form factors of trees after they are 90 or 100 years is, till do certain that 40-year age-classes are small enough. In our work with form factors it is desirable to make separate tables for young and for old trees. No rule can be given for the limits of the age-classes because these would differ under different circumstances. Thus it might be best to group the trees 50 to 100 years, or those 60 to 120 years of age. Ordinarily groups of 50 to 75 years will suffice for the present requirements of our investigations.

Influence of Change in Diameter on the Size of Form Factors.—

There is no uniform relation between form factors and diameters of trees. The form-factor tables given in the Appendix illustrate the lack of uniformity in the variation of form factors of the different species.

94. Construction of Tables of Form Factors.—To construct a table of form factors a large number of trees are felled and measurements of volume taken. The volume and form factor of each tree are then computed and the results for trees of like diameter and height averaged together. Thus the form factors of all trees rounding to 6 inches and 25 feet are averaged together, the form factors of the trees 7 inches by 25 feet, those 8 inches by 25 feet, and so on. A convenient form for averaging the values is that on page 180, in which the number in the center of each square is the average form factor, the number in the upper left-hand corner is the average diameter of the trees measured, the number in the upper right-hand corner the number of trees averaged, and the number in the lower right-hand corner the average height of the trees measured.

The next step is to inspect the values in this preliminary table to see how the form factors vary. If the form factors are found to vary regularly with the increase of diameter and height, it is necessary to make a table for both diameters and heights. If upon inspection of the first table of averages of the form factors, it is found that there is a distinct change in their values with

Diameter, Breast-high, Inches.	Height in Feet.			
	40	45	50	55
	Average Merchantable Form Factors.			
6	6 0.470 40	6.2 0.465 45.7	6.3 0.463 49	
7	7.3 0.461 39.5	7 0.457 44.8	6.8 0.441 51.2	7 0.438 55
8	8.1 0.457 41	8.0 0.450 46	8.2 0.440 50	8.0 0.430 56

increase in diameter, but no appreciable change with increase in height, the final table is made by averaging together the form factors of trees of different diameters without regard to heights. In the same way, if the values of the form factors are found to change with increase in height, but not with increase in diameter, the form factor table is based on heights alone. It usually happens, however, that there is a certain amount of irregularity in the horizontal and vertical column, even when the table is based on a large number of measurements. These irregularities may be evened off by a series of curves.

As a rule, tables of stem form factors for coniferous trees are based on diameter alone. Behm's tables for Norway spruce, European fir, and larch over 90 years old are constructed on the basis of the average form factors of trees of different diameters without regard to height. The tables for silver fir and larch 60 to 90 years old are constructed in the same way, but the table for spruce 60 to 90 years old is based on both diameters and heights.

The table of tree form factors for Scotch pine is constructed on a basis of heights without regard to diameters. Behm gives also a table of tree form factors for beech over 90 years old, based

on diameters and heights, while that for beech 60 to 90 years old depends on heights alone.

In spite of the opinion of many European authors that tables of stem form factors for mature coniferous trees should be based on diameters alone, the most important hand-books of Germany and Austria give, for use in practical estimating, stem form factors of these trees averaged by heights without regard to diameters. This lack of uniformity in construction of tables of form factors in Europe is extremely confusing to the student. It is best, in making a table of form factors, not to try to follow any rule, but to determine, by an inspection of the preliminary table of averages, whether the final tables should be based on diameters alone, heights alone, or both diameters and heights.

Tables of form factors are considered worthless by European foresters unless founded on a very large number of measurements, and, indeed, the form of individual trees varies so much that a satisfactory average cannot be obtained unless several thousand trees are measured.

The Bavarian volume and form-factor tables, begun in 1846, were based on 40,000 trees. The tables for pine elaborated by Schwappach depend on 17,000. Baur's spruce tables are based on 22,000 trees and Schuberg's fir tables on 5643 trees. These German tables are designed to show the laws of the form of trees throughout large areas. This does not mean that in this country the practical use of form factors is excluded under circumstances where it is impossible to make such an extensive study. Local volume tables may be based on a relatively small number of measurements. The accuracy of such tables is, however, in direct proportion to the number of measurements used in their construction. But in the preliminary work of forest organization in this country the forester must often be satisfied with tables which give only approximate results. Local tables of volume and form factors based on 100 trees are often used in this country with fairly satisfactory results. They must,

of course, eventually be replaced by tables based on more thorough investigations. If the trees are separated into classes, 100 trees for each class will often suffice for volume and form-factor tables to be used in estimating standing timber.

95. Absolute Form Factor.—As explained above, the absolute form factor is obtained by dividing the volume of a tree by the product of its height and the basal area taken at the true base. Naturally the absolute form factor is not applicable to the full contents of a tree because of the difficulty of measuring the diameter at the ground. It is, however, sometimes applied to the portion of the tree above breast-height.* In this case the absolute form factor is found by dividing the volume of the tree above breast-height by the product of the breast-height sectional area and the height of the tree above that point. When this factor is used in cubing trees, the portion below breast-height is considered a cylinder having the same diameter as that at breast-height.

96. Normal Form Factor.—This is a theoretical formula which was at one time used in practice by its inventor, Pressler. The normal form factor is the volume of the tree divided by the product of height and the sectional area at a height in fixed proportion to the height of the tree. This proportion is generally assumed as $1/20$. Then

$$\text{Normal form factor} = \frac{V}{H \times B \left(\text{taken at } \frac{H}{20} \right)}$$

97. The Conception and Use of Form Exponents.—Analytical geometry teaches us the mathematical expression for the curves whose revolution about an axis will form a cone, an Appolonian paraboloid, a Neilian paraboloid, etc.

The straight line parallel to the axis is represented by the equation $y = p \cdot x$.

* Sometimes called Rinniker's absolute form factor.

The curve generating an Appolonian paraboloid, by the equation $y^2 = p_2x$.

The curve generating a cone, by the equation $y^2 = p_3x^2$.

That generating a Neilian paraboloid by the equation

$$y^2 = p_4x^3,$$

in which x is the abscissa, y the ordinate, and p, p_2, p_3, p_4 are constants, the so-called parameters.

The general expression applicable to any one of these curves is

$$y^2 = px^r.$$

The form of the body produced depends on the exponent r , which is called the form exponent or form coefficient.

It is possible to determine the form exponent of a stem or log by a few measurements.

Suppose that it is desired to find the exponent of form of a log such as that shown in Fig. 36. Let x_1 be the distance

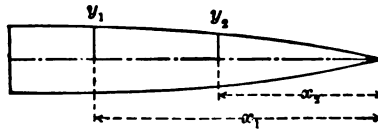

FIG. 36.

from the tip of the tree to the base of the log, x_2 the distance from the tip of the tree to the top of the log, y_1 the radius of the base, and y_2 the radius of the top. Then

$$y_1^2 = px_1^r \quad \text{and} \quad y_2^2 = px_2^r.$$

If the first equation is divided by the second, then

$$\frac{y_1^2}{y_2^2} = \frac{x_1^r}{x_2^r} = \left(\frac{x_1}{x_2}\right)^r,$$

from which

$$r(\log x_1 - \log x_2) = 2(\log y_1 - \log y_2),$$

$$r = 2 \frac{\log y_1 - \log y_2}{\log x_1 - \log x_2}$$

Example.—Suppose that the two measured diameters are 18 and 15 inches,* and the lengths are 61 and 45 feet.

$\log y_1 = \log 1.5 = 0.176091$	$\log x_1 = \log 61 = 1.785330$
$\log y_2 = \log 1.25 = 0.086910$	$\log x_2 = \log 45 = 1.653213$
Difference = 0.089181	Difference = 0.132117

$$r = 2 \times \frac{0.089181}{0.132117} = 2 \times 0.675 = 1.35$$

The cubic contents of the stem of a tree may be determined by the formula

$$V = \frac{1}{r+1} \cdot \frac{\pi}{4} D^2 H,$$

in which V is the volume, D the diameter at the base, H the length and r the form exponent. In this formula the diameter is taken at the base of the tree. For the breast-height diameter the following formula must be used:

$$V = \frac{1}{r+1} \cdot \frac{\pi}{4} D^2 \left(\frac{H}{H-4\frac{1}{2}} \right)^r H.$$

Space does not permit a full mathematical explanation of the derivation of these formulæ. An algebraic derivation of the formula is described in Müller's *Holzmesskunde*, page 12, and a proof by calculus is contained in *Lehr- und Handbuch der Holzmesskunde*, by Langenbacher und Nosseck, page 68.

98. Form Height.—By form height is meant the product of the form factor by the height of a given tree. The German tables of form heights are constructed for convenience in determining the cubic contents of trees by the use of form factors.

* In practical calculations it is immaterial whether the diameters or radii are used.

99. **Special Methods of Determining Form Factors.**—*Philipp's Method.*—In 1896 Karl Philipp of Baden published, in a pamphlet entitled *Hilfstabellen für Forst-taxatoren*, a new formula which serves as a mathematical expression for all forms of trees. The equation representing any stem curve is as follows:

$$y^{2n} = px^m - n.$$

In using this formula, the form factor is based on the volume and height of the stem above breast-height (1.3 meters). The form factor is expressed by the fraction $\frac{n}{m}$. Suppose that the form factor is 0.47, expressed as a vulgar fraction $\frac{47}{100}$, then $n = 47$ and $m = 100$, and the equation reads:

$$y^{94} = px^{100}.$$

The formula is used to determine the form factor of a tree in the following way:

Let D be the breast-height diameter, d the diameter at a point on the stem representing a fixed and arbitrary proportion of the height (usually 0.4 of the height), H the height above breast-height, and h the distance from the point where d is measured to the tip. Then

$$\frac{n}{m} = \frac{1}{1 + 2 \frac{\log \frac{D}{2} - \log \frac{d}{2}}{\log H - \log h}}$$

Strzelecki's Method.—The following method was described by Forst-director Heinrich Ritter von Strzelecki, a Galician forester, in the *Centralblatt für das gesammte Forstwesen*, 1883. It is interesting and may in some cases prove of practical value.

With a paraboloid as a model, it is assumed that, if d is the diameter at one-half the height and D is the basal diameter, then

$$d = \sqrt{\frac{1}{2}D} = 0.707D, \text{ or } \frac{d}{D} = 0.707.$$

The quotient $\frac{d}{D}$ is greater or less than 0.707, according as the trunk of the tree is greater or less than a paraboloid, and in the same proportion as the form factor will be greater or less than 0.50. Expressed in a formula,

$$0.707 : \frac{d}{D} = 0.5 : F, \text{ or } F = 0.707 \frac{d}{D}$$

The volume of the tree would then be

$$V = 0.707 \frac{d}{D} \times B \times H,$$

in which V is the volume, B the basal area, H the height.

To obtain the volume of a tree, measure the height, the diameters at the base and at the middle point, the latter with a dendrometer, and apply the above formula.

Pressler's Method.—As explained on page 156, Pressler's formula for cubing standing trees is:

$$V = \frac{2}{3} B \left(H + \frac{M}{2} \right).$$

Substituting this value of V in the formula $F = \frac{V}{BH}$, then

$$F = \frac{\frac{2}{3} \left(H + \frac{M}{2} \right)}{H}.$$

The Form Factor Determined from the Form Exponent.—The formula for cubing a tree when the form exponent is used is as follows:

$$V = B \times H \times \frac{1}{r+1} \left(\frac{H}{H-4.5} \right)^r.$$

The form factor is therefore

$$F = \frac{1}{r+1} \left(\frac{H}{H-4.5} \right)^r.$$

When the basal area is taken at the true base, and not at breast-height,

$$V = B \times H \times \frac{1}{r+1}.$$

The absolute form factor is then

$$F = \frac{1}{r+1}.$$

Nosseki's Method.—As explained above, the absolute form factor may be expressed by the formula

$$F = \frac{1}{r+1},$$

in which F is the form factor and r is the form exponent of the tree. The volume formula would then read

$$V = \frac{1}{r+1} \times B \times H,$$

where B is the basal area at the stump cut. If now the breast-height diameter is D , m the distance from the stump to breast-height, and d the diameter at $\frac{H-m}{2}$, then

$$d^2 : D^2 = \left(\frac{H-m}{2} \right)^r : (H-m)^{r-1} : r,$$

or

$$\frac{d}{D} = \frac{1}{\sqrt{2^r}}.$$

If this equation is multiplied by $\frac{\sqrt{2^r}}{r+1}$, then

$$\frac{d}{D} \times \frac{\sqrt{2^r}}{r+1} = \frac{1}{r+1} = \text{Absolute form factor.}$$

If B is the area at breast-height the formula would read:

$$\text{Form factor (breast-height)} = \frac{d}{D} \times \frac{\sqrt{2^r}}{r+1} \times \frac{1}{\left(1 - \frac{m}{h}\right)^r}.$$

A table was prepared by Nossek showing the value of the above equation for all values of $\frac{d}{D}$ and of H which might be required. In practice one determines D , d , and H by measurement, and then looks in Nossek's tables for the corresponding value of f . The volume of the tree is then readily obtained.

Schaal's Method.—Forstmeister Schaal of Grünthal, Germany, published in the Allgemeine Forst und Jagd Zeitung, August 1885, the following simple method of determining the form factor of a tree: An observer determines the angles formed by sighting a clinometer to the tree-tip and to the point on the trunk where the diameter is one-half that at breast-height. The form factor of the stem is then obtained by the formula

$$F = \frac{2 \text{ tangent } b}{3 \text{ tangent } a}$$

in which F is the stem form factor, a and b are the angles obtained by sighting to the tip and the half-diameter point of the tree.

This method gives only approximate results.

100. Method of Form Quotients.—It has already been explained that there is a great difference in form factors of different trees of the same diameter and height, and that this difference prevents the use of average form-factor tables with single trees. The method of form quotients has been devised to enable the quick computation of the form factor and the volume of a single tree. The form quotient is the ratio between the diameters at the middle of the stem of the tree and at breast-height. Expressed algebraically, $q = \frac{d}{D}$, d being the diameter at the middle of the stem, D the diameter at breast-height, and q the form quotient. This ratio is an excellent expression of form, because the form quotients of trees vary directly with the volumes. It is a convenient expression because it is easily determined, even for a standing tree, and enables the rapid computation of volume.

The form quotient has a close relation to the stem form factor of a tree, and the difference between the form factors and form quotients of a number of trees of the same species is very uniform. Thus, for example, it has been found that the constant difference between the form factors and form quotients of Scotch pine is 0.2, of Norway spruce 0.21, of beech between 0.22 and 0.23.

These constants may be used to determine the form factors and the volumes of standing trees in the following way:

The diameter at breast-height is measured with calipers; then the total height and distance of the middle point above the stump are determined with a height measure; then by estimate or measurement with a dendrometer, the diameter at the middle point is determined. The form factor is then found by subtracting from the form quotient the constant difference between form factor and quotient for the species in question. Expressed

as a formula, $F=q-c$, F being the form factor, q the form quotient, and c the constant.

The constant for a given species varies slightly with the height of the tree. The variation is not great, particularly for trees between 40 and 100 feet. As the trees whose volumes are required are usually within this range of height, an average value for c may be used in practice.

Prof. Judson A. Clark has made a study of form quotients of balsam fir in the Adirondacks, which indicates that the method can be successfully applied in practice in this country.

CHAPTER XIV.

DETERMINATION OF THE CONTENTS OF STANDS.

101. Problems of Determining the Contents of Stands.—

The purpose of studying the volume of single trees, of making volume tables and tables of form factors, is to facilitate the computation of the contents of stands. Occasionally a single tree is sold and its volume desired, but ordinarily the single tree is of interest to the forester only as it forms a part of a whole stand or forest.

In general, there are two distinct sets of problems in determining the volume of stands:

First, those requiring an estimate of merchantable volume, used in valuing forest land for possible purchase or sale and in making plans for lumbering.

Second, those involving an accurate determination of volume, used in studying increment and future yield.

Various methods of estimating the contents and value of timber have been developed in different parts of the country. These methods differ in the degree of accuracy of the results and each is designed for a particular region and set of conditions. The methods of accurate determination of the volume of stands are mostly adopted from European practice. The problems of studying the volume of stands are so varied under different conditions in this country that in a general book on forest mensuration it is desirable to describe all the more important methods of work. An explanation is given, with each method, of the kind of problem for which it is specially designed, in order that the student may not be confused by their large number.

102. Timber Cruising.—The determination of the merchantable volume and value of standing timber is called *Timber Cruising* or *Timber Estimating*. In this country and Canada there is a body of professional cruisers (also called estimators, land-lookers, or land-valuers) who make a business of estimating the value of forest land and its possibilities for profitable lumbering. These men are so skilled that they can estimate, merely by inspection, the merchantable contents of a standing tree or the approximate yield per acre. The most experienced cruisers can estimate pretty closely the yield of an entire township or section without taking a single measurement.

It is absolutely impossible to learn from books how to estimate timber, for it is not a matter of method, but of judgment, which can be acquired only through experience and practice in the woods. A cruiser is able to judge by the eye the merchantable contents of a tree because he has seen trees of the same character and size cut and used, and he knows what they produced. In the same way a cruiser can estimate the contents of a stand by comparing it to similar stands whose actual product he knows. The cruiser must understand the local conditions of lumbering in order to know what trees are merchantable from the standpoint of size and condition. He must be able to recognize the external signs of defect and judge the amount of loss through hidden imperfections; and in order to place a value on the timber he must be able to judge the cost of lumbering. This is not a matter of information which can be given in a book, but of field training. It is, however, possible to describe the general methods of the cruiser in different kinds of problems and the aids which he uses to guide and check his judgment.

103. Estimate by the Eye.—This method was formerly used almost universally to determine the value of standing timber. The available timber was so plentiful and cheap that a very accurate estimate of the amount on any specified tract was not essential. Usually the cruiser's guess, based on a superficial

examination of the land, was sufficient for the purchaser. In recent years, as the value of land has increased, greater accuracy is required, so that in many sections the estimates are now based on very careful methods which involve actual counts of trees. Purchasers were formerly satisfied if the estimate underran the real product of the land. But now very close estimates are required because a considerable underestimate might cause a buyer to lose a chance for profitable investment; while an overestimate might cause the purchase of land at too high a figure. Nevertheless transactions in land are to-day constantly made on the basis of ocular estimates by cruisers.

There is no uniform method of work in making an ocular estimate of timber on a given tract. Each cruiser does the work in his own way. Suppose that a township of timber is to be estimated. The cruiser goes over the tract examining the character of the timber with more or less care and then guesses at the total yield or the yield per acre. If the timber is fairly uniform in size and evenly distributed over the ground the estimate may be made in a short time. Usually the timber is not uniform, but has a different yield in different portions of the township, so that each portion must be estimated separately. Thus if there is a mountain on the tract, the north slope may be estimated separately from the south slope, the lower slopes separately from the upper slopes, the different water-sheds, swamps, or other special types of land, also separately.

Some cruisers guess at the total contents of a township or part of a township in million and fractions of million feet; others estimate first the yield per acre, multiplying by the known or supposed number of acres in the area. The estimate by the eye is being rapidly replaced by methods dependent, at least in part, on counts of trees on the whole area or on small sample areas. The estimate by the acre is more reliable than the general guess, because the cruiser constantly checks his judgment by laying off sample areas and estimating the contents of standing timber on them.

There are several methods of laying off rough sample areas

without measurement. One way often used by cruisers is to count the trees in a circle having an estimated radius of 7 rods, which covers an area of about one acre. In the spruce forests of the Northeast this is about as far as one can distinguish a tree by its bark. After counting the trees the cruiser estimates the contents of an average tree and multiplies by the number of trees for the yield per acre. A quicker way is to count the trees in a circle of 60 feet radius, which covers an area of approximately one-quarter acre, or a circle of 85 feet radius, covering an area of about one-half acre. If the forest is very open, one should use a whole acre if possible, as a smaller area may not represent average conditions.

Another method is to count the trees in a narrow strip. One paces off 10 yards, stops and counts the trees for a distance of 2 rods on each side, then paces another 10 yards, again counting the trees, and so continues until he has paced 165 feet, which comprises an area of one-quarter acre; or he paces off enough to make a half or a whole acre.

There are several ways of estimating the volume of the average trees required in these methods of rough sample areas. Some estimate by the eye the average yield per tree. Some estimate the average number of logs per tree, and knowing from the experience at the local sawmills the average contents of the logs, determines the average yield of the standing trees. Another way is to select several trees of average size, estimate their volume, and use the average of these as the required average yield per tree in the forest. Cruisers often have rules of thumb for estimating the volume of certain species. (See page 153.)

Sometimes cruisers lay off square plots by pacing the sides and measuring the corner angles with a pocket compass. The laying out of measured plots is described in connection with the accurate determination of the contents of stands.

A convenient form for use in estimating timber is used by the forest officers on the federal reserves. The forest reserves are divided into so-called blocks, districts, and divisions. Sepa-

rate estimates of standing timber are made for each of these divisions, the forest officer being allowed to choose his own method of making the estimate. Usually the forest officer estimates by the yield per acre, judging this by the eye or by rough sample areas, such as have been described. The data secured are entered in the following form, which has been filled out to make it clearer.

ESTIMATE SHEET.

Estimated stand per acre on Block 5, District 8, Division 3. (Here state whether for entire block, portions of block, or tract applied for only.) Covers entire block.

LIVING TIMBER.

Species (to be written in)	{ Bull Pine					Total
Number of trees above 8 ins. per acre	70					70
Average height of trees	55					55
Average number of trees per M.	16					16
Average stand, B. M., per acre.	4400					4400
Percent deduction for defect	5%					5%
DEAD TIMBER SOUND ENOUGH FOR USE.						
Number of trees above 5 inches per acre						2
Average stand, B. M., per acre						
Cords down timber per acre						1
Cords standing timber per acre, suitable for fuel only						1

What percent of total was actually estimated and what system was used? 10 percent of the timbered area (155 acres). $\frac{1}{4}$ acre, circle method.

JOHN DOE, Head Ranger.

104. Estimate by the Inspection of Each Tree in a Stand.—

Most of the more accurate methods of estimating used by cruisers in this country are based on an inspection of every merchantable tree in a given stand. The simplest method is to count the

merchantable trees, then determine the volume of an average tree and multiply this volume by the total number of trees.

In mountain districts where the land is rugged and there is a constantly changing topography, the merchantable trees are often scattered or in small groups. It is then comparatively easy to count the merchantable trees without danger of including any one tree twice. If there is danger of counting trees more than once, each one, when it is inspected and counted, is blazed or otherwise marked. A method requiring greater skill is to estimate the contents of each tree as it is inspected. When each water-shed or secondary water-shed, ridge, plateau, or other type of land is finished, the figures are added together for the total.

A third plan is to measure each tree with calipers and determine the contents of the stand by volume tables. This method is described in section III.

The following is a description of how the method described above was applied in estimating the timber in Pisgah Forest, North Carolina.*

1. Each tree is approached individually, its diameter measured, and its defects, especially its hollowness, examined by "sounding." The diameter measure and the estimated volume are entered on a tally-sheet opposite the number of the tree, which is inserted in the stump of the tree by a stroke of the "revolving numbering hammer."

2. One cruiser and one helper tally 400 trees per day.

3. The method allows of ready control by the owner, the forester, and the buyer. It is adapted to hardwood forests in a rough mountainous country where the merchantable trees per acre are few and where practically no tree is free from defects.

Where the trees are counted and not measured, it is more convenient to record the count on a tally register than on a tally-sheet or note-book.

* Forest Mensuration, by Dr. C. A. Schenck, page 42.



FIG. 37.—Tally Register. This instrument consists of a metal box or case about 2 inches in diameter and $\frac{1}{2}$ inch thick, containing a mechanism including three numbered wheels the edges of which are exposed through a small glass disk set in the center of the front of the case. The wheels are turned step by step by a plunger projecting through the edge of the case in position to be operated by the thumb. The box is carried within the palm of the hand and held by a ring through which the middle finger is passed. It counts from 1 to 999 and costs \$2.50. (See Fig. 37.)

105. A Method Used in Michigan.—In a flat country—as, for example, in the Lake States—it is more difficult than in the mountains to keep track of the counted trees and not to go over the same ground twice. In such regions a number of systematic methods, which differ in detail with different cruisers, have been developed. The method described in the following paragraph is used by a Michigan cruiser and is given as a typical example:

In Michigan the land has been subdivided into square quarter-sections of 160 acres, each of which is further divided into plots of 40 acres. A "forty" is 80 rods square. The cruiser who uses the method now to be described has found by trial that 500 of his natural paces are required to go 80 rods. He begins at the corner of a "forty"—say, at the southeast corner—and steps off 125 paces on the south line, and so covers one-quarter of the side of the "forty." (See Fig. 38.) He then stops, and, facing north, counts the trees first to an estimated distance of 125 paces on the right hand, and then to an estimated distance of 125 paces on the left hand, and in each case to a distance of 100 paces in front of him, thus including the area represented in the diagram as Plot I. He then steps north 100 paces, and in the same way counts the trees on Plot II, and repeats the operation successively for Plots III, IV, and V. This gives a complete count of the trees on the eastern half of the "forty." He then walks

west 250 paces along the north line of the "forty." Facing south he now counts all the trees in Plots VI, VII, VIII, IX, and X in the same way as before, and thus completes counting the trees on the entire "forty." As he goes over the ground he constructs a rough map, locating the ridges, streams, swamps, and windfalls. He also makes notes of the general character of the timber and of any other information useful to the owner of the land. When the work is completed the cruiser has a practical working-map for carrying on lumber operations in addition to the other material secured. It is obvious that this method can be used only on comparatively level ground.

Another similar method is described by A. S. Williams in the Forestry Quarterly, Vol. II, No. 3.

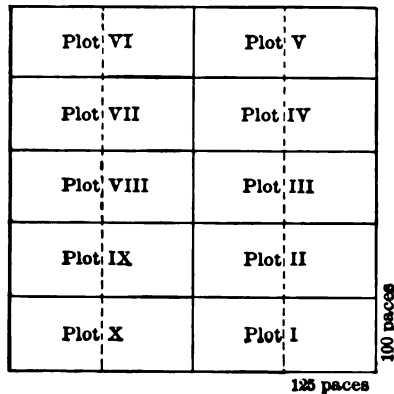

FIG. 38.

106. Estimating by Working over Small Squares.—Another method of cruising which gives good results is to divide each "forty" into 16 small squares of $2\frac{1}{2}$ acres and to estimate the timber on each square separately. This method and the one following were described in an article in Rod and Gun of Canada, November, 1901, by A. Knechtel. The following description is essentially the same as given in that article:

The cruiser begins at one corner of a "forty"; for example,

at the southeast corner. He paces along the south line 10 rods east and then turns and paces 10 rods north. This brings him to the center of a square $2\frac{1}{2}$ acres in extent, or one-sixteenth of the "forty." Standing at this point he locates by the eye the boundary-lines of the square and then estimates the timber upon it, usually by counting the trees and determining their contents from volume tables.

In dense stands where the trees cannot be readily counted, a flag may be placed at the center of the square to guide the cruiser. He then paces 5 rods south and then 5 rods west, which brings him to the center of the southwest quarter of the square. He estimates this small plot and then paces 10 rods north, where he stands and estimates the northwest quarter of the $2\frac{1}{2}$ -acre square. He then paces 10 rods east and estimates the northeast quarter of the square and then paces 10 rods south and estimates the southeast quarter. Having completed the estimate of one $2\frac{1}{2}$ -acre square, he returns to the flag and paces from this point 20 rods north, which is the center of the second $2\frac{1}{2}$ -acre square which he estimates in the same way as before. This operation is continued until four squares have been estimated. The cruiser then takes in hand the tiers of squares directly east of the first series until the 16 squares, or the entire "forty," have been covered. (See Fig. 39.)

107. Estimating in 40-rod Strips.—A method sometimes used in Michigan is to estimate the timber in strips 40 rods in width and one-half mile long, which cover exactly 40 acres. The cruiser is assisted by a lineman, who runs a compass line along one side of the strip, measuring its length by pacing. The cruiser passes back and forth over the strip estimating the timber. He paces the distance when going away from the lineman, who guides him, when returning, by a policeman's whistle. When a strip of one-half mile, or 40 acres, has been completed, an adjacent strip is cruised in the same manner.

108. Erickson's Method.—An excellent method of cruising is that devised by M. L. Erickson of the U. S. Forest Service.

It consists in gridironing a given tract by strips 4 rods wide and usually $\frac{1}{4}$ mile apart, and recording the estimated breast-height diameter of each tree and the estimated top diameter of each merchantable log. If there is a crew of two men, one directs the strip on a compass-line and paces the distance, the other records the diameters of the trees and logs. The compassman first paces off a short distance—for example, ten yards—and waits until the tallyman records the trees in that distance and

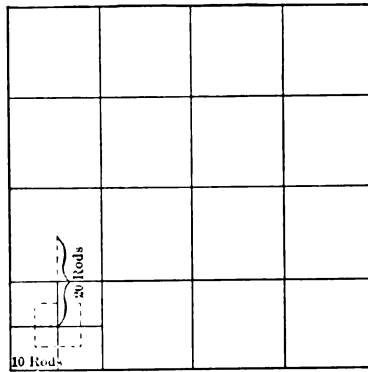

FIG. 39.

comprised within a 4-rod strip. The tallyman records on a tally-sheet, like that shown on page 200, the estimated breast-height diameter of each tree and the estimated top diameters, inside the bark, of each 16-foot log. The compassman keeps track of the distance paced, and makes a note of roads and streams crossing the strip, and of any other information required in the cruise. The strips, together with the roads, streams, and other features, may later be plotted on a map. A separate tally-sheet is used for each strip, or part of strip, for which a separate estimate is required. Thus a new record is made when a different watershed is reached, when the compass direction of the strip is changed, when a different forest type is encountered, etc.

The records enable the determination of the contents of the

logs by any desired log rule, the determination of the total number of trees, the average number of logs per tree, the number of trees or logs per thousand board feet and the yield per acre. One of the advantages of the method is that each tree is scaled for what it will yield, and crooked and defective logs discarded. The only deduction required in the final total scale of a tract is a certain percentage for hidden imperfections not apparent on the standing trees.

In the spruce forests of New Hampshire one crew of two men can work over in a day a strip $1\frac{1}{2}$ miles long. If the strips are laid off $\frac{1}{4}$ mile apart, this means a cruise of 300 acres per day.

The method requires not only a knowledge of what constitutes a merchantable log, but also the ability to estimate diameters. It requires a trained eye and cannot be practised by a novice.

RECORD OF ESTIMATED DIAMETERS.

Locality, Waterville, N. H. *Block*, Snow Brook. *Compartment*, II.
Species, Spruce. *Strip*, No. 17. *Course*, N. 8° E. *Length*, 120 rods.

Diameter, Breast-high Inches.	Number of Trees.	Top Diameter of Logs Inside Bark, in Inches.									
		6	7	8	9	10	11	12	13	14	15
		Number of Logs.									
8	12	91	83	68	59	44	33	16	8	8	
9	17										
10	12										
11	22										
12	30										
13	35										
14	15										
15	12										
16	10										

109. **Estimate by Use of Stand Tables.**—Stand tables show the average volume per acre of stands of different character.

When the yield per acre is shown for fully stocked even-aged stands at different ages, stand tables are the same as normal yield tables (described on page 318). When stand tables show the actual average yield of even-aged stands in a specified locality or region, they are the same as empirical yield tables. Most of the stand tables so far made in this country show the average number of trees of different sizes and the volume per acre of the timber growing on specified tracts, and are used in estimating the total present yield and future growth on given tracts.

Stand tables are valuable as a standard of comparison in estimating timber. Suppose, for example, that one were estimating a stand of chestnut and oak sprouts thirty years old; suppose, also, that average stand tables have been made for the region showing the average yield of oak-chestnut sprout stands at thirty years of age to be 27 cords per acre, one judges by the eye whether the stand in question is better or poorer than the average in the region and estimates the yield of the stand by using the 27 cords as a standard of comparison. The timber cruiser has such average yields in mind; that is, stand tables are merely a tabulated statement, resulting from actual measurements, of the information constantly used by the cruiser.

Normal yield tables are, however, somewhat different, because they are based on the yield of fully stocked stands. They are applicable in estimating only to even-aged and usually only to pure stands. Suppose, for example, that one were estimating a stand of 50-year-old white pine, such as often is found in New England. Suppose, also, one has a normal yield table which shows a yield of 55 cords per acre for a normal stand of pure even-aged white pine. The stand is inspected and the deviation from normal stocking estimated. Suppose that it were estimated that it has only 80 percent of what might be growing. Then the yield per acre is 55×0.8 , or 44 cords. Such a plan of estimating is especially useful in very small growth. It is used constantly in Europe to estimate the growing stock of young stands in making working-plans.

110. Estimate by the Use of Valuation Surveys.—By valuation survey is meant the measurement of the diameters of the trees or other detailed study on a known area. The counting of trees on an estimated circle or paced plot described on page 193 is a form of valuation survey, though the term is applied usually to the work on measured areas where the trees are calipered or their diameters estimated. The area upon which the measurements or other detailed studies are made is called the *valuation area*, *sample area*, or *sample plot*. A *strip survey* comprises the measurement of a stand on a narrow strip, usually one chain wide. If the valuation area is a square or any other shape than a narrow strip, the work on it is called a *plot survey*.

Valuation surveys are used extensively in estimating timber, not only as checks to ocular estimates, but when a large number are taken, as a complete mathematical basis for the computation of the volume of a given tract.

Their use in estimating timber and in exact studies of the contents of stands is described in the succeeding sections.

111. The Use of Strip Surveys.—The principle of this method is to measure the trees on narrow strips distributed systematically over the forest and covering in the aggregate a specified percentage of the total area. These strips are known as strip valuation surveys, or strip surveys. In the practice of the U. S. Forest Service the strip surveys are one chain in width, and for each ten chains of length, that is, for each acre, the tree measurements and forest descriptions are kept separate.

The work of laying-off the strips requires a crew of at least three men. One, called the tallyman, carries a note-book or tally-sheets, and records the species and their diameters as they are called out by two calipermen, and also makes the required descriptive notes. The strip is measured off in length with a surveyor's chain in the following way: The chain is stretched on the ground in the chosen direction, the tallyman carrying the forward end and one of the calipermen the other end, and the trees within an estimated distance of 33 feet (one-half chain)

on each side of the chain are then calipered. Then the crew moves forward another chain length in the direction indicated by the tallyman, the chain laid on the ground and the trees calipered on each side of it as before. This same operation is repeated until ten chains have been measured.

If there are four men in the crew, one man determines the direction of the strip with a compass and carries the forward end of the chain, two men caliper the trees, and the fourth makes the records. The compassman directs the work of the crew, seeing that the calipering is accurately done, that no unsound trees are measured, that the calipermen keep within 33 feet on each side of the chain, and he makes observations required for the descriptive notes which he dictates to the tallyman. As it is difficult for the compassman to direct the course and at the same time make observations of the character of the forest and oversee the work of the other men, a fifth man is sometimes added to the crew. This enables the leader of the crew to devote his whole attention to directing the work and making the descriptive notes.

If the trees are to be counted and not measured, two men in a crew are sufficient, one to do the counting, the other to manage the compass and the forward end of the chain, record the counts, take notes on the forest, lumbering, topography, etc.

112. Distribution of the Strip Surveys.—There are two general methods of distributing the strip surveys over a given tract; first, to lay them off in long strips running across the tract, parallel and equidistant; and second, to locate them as isolated sample areas.

The U. S. Forest Service uses the strip method not only to obtain estimates of the merchantable timber, but also to secure a count of the trees not yet merchantable, to make forest maps, and to gather other detailed information necessary for a practical forest working-plan. Under these circumstances lines of strip surveys are usually laid off parallel and equidistant, and run across the entire tract. Suppose, for example, that a town-

ship in a region like the Adirondacks is to be estimated. The first step is to determine the percentage of the area to be included in the valuation surveys and to make a plan for the distribution of the strips over the area under investigation. Usually one side of the tract is chosen as a base-line and the strips are laid off at right angles to it and at equal distances apart. Stations are marked along the base-line to indicate the location of the strips. The crew starts at the first station, which is close to the end of the base-line, and runs a line of 10-chain strip surveys across the tract in a direction determined upon in advance. Upon arrival at the farther side of the tract, the crew paces along the line the distance which is to separate the strips. Then a second line of strip surveys is laid off parallel to the first and running in the opposite direction to station No. 2 on the base-line. As soon as the base-line is reached the crew paces the distance to the third station, whence a new strip is started parallel to the other two, and so on until the whole tract has been covered. Inasmuch as the lines are run with a pocket compass, it is difficult in rough country to exactly meet, on the return courses, the fixed stations on the base-line, as, for example, station No. 2. Most investigations do not require that the strips be precisely equidistant, so that often there are no fixed stations; but the crew starts at a predetermined point near one end of the base-line and lays off strips as nearly parallel and equidistant as possible, not trying to reach upon the return strip any fixed point. The exact location of the strips is, however, carefully recorded on the map. This plan gives a little more elasticity to the method, often desirable in rough country.

As the strip method is ordinarily used, the chaining is not done very carefully. Thus, it is often customary for the compassman to attach the chain to his belt at the back and to mark off the distances merely by scratching the surface of the ground with the heel and not to mark by a pin or stake. The chaining is usually not done on the horizontal, but the lengths are measured along the ground regardless of the slope. A valuation survey

run up and down a steep slope covers an acre of surface, but is less than 10 chains long when projected on a map. On account of the errors from this inaccurate method of chaining, the strips often do not fit precisely into the map. There is not, however, any considerable error in an estimate arising from this lack of precision in chaining because the errors in laying off single acres largely compensate each other. It is only when the chaining is used for a topographic map as well as an estimate that accurate chaining on the horizontal is necessary.

It often happens, in running a line of strip surveys across a given area, that the last strip is less than 10 chains in length. Strictly this should be regarded as a fraction of an acre. Thus, for example, if the last strip is $4\frac{1}{2}$ chains in length, it comprises 0.45 of an acre. When the results of the measurements on this short strip are used, it is necessary to express them in terms of whole acres by dividing by 0.45. In practice, however, where the forest is uniform, the whole acre is completed, either by continuing over the line or by turning and finishing inside the line in another direction, in order to facilitate computation and avoid fractional acres whose results must be converted into terms of whole acres.

It is easy to see that the systematic gridironing of a tract, as above described, would not always be the best plan of distributing the strip surveys. Thus, for example, in mountain country, where the merchantable timber is located in certain types of land or in certain portions of a tract, and on small or very irregularly shaped tracts, it is usually better to lay off strip surveys more or less irregularly, and often as isolated sample plots, in such a way as to obtain an average yield per acre of the type or area under immediate examination. Suppose that the timber in a small water-shed is to be estimated and that the yield per acre differs materially along the stream from that on the slopes, isolated strip surveys are taken and the yield per acre determined separately for each type of forest. In less mountainous regions the strips are sometimes laid off radially

from a central point, or run in a zigzag fashion over a given area. The strips are, therefore, laid off by judgment and not by rule, as in the gridiron method.

In general the gridironing plan is used in level, rolling, or moderately mountainous country and where a forest map is required in addition to an estimate of the volume of the timber.

The method of isolated strip surveys is preferable in very rugged regions where the merchantable timber is confined to certain types of forest or to certain areas of the tract and where a separate estimate is required for each type or area; and on small tracts or those very irregular in shape.

113. Data for a Forest Map.—The preparation of the forest map is often combined with the estimate. In most cases a contour map is not designed, but rather a map which will show the distribution of the timber, the forest types, the location of the roads, streams, and main ridges. Such a map is prepared in the following way: When a strip intersects a road or stream the tallyman notes the point of intersection and also the direction of the road or stream, so that it can afterwards be located on the map. If a road or stream crosses several strips the points of intersection are connected on the map and the exact location thus indicated. When a stream or road is crossed, the tallyman takes any necessary notes as to its character and width. The description of each acre includes the general direction of the slope, and if there is a marked change in the degree of slope in the middle of the acre, that fact and the point where the change occurs are noted. The location of ridges may thus be determined from the descriptions of each acre and sketched on a map.

It is possible, also, to make a map of the forest types because the description of each acre includes a statement of the type. If an acre crosses from one type into another, this fact is explained on the tally-sheet and the point indicated where the change occurs. The outlines of the different types may be sketched on the map in the same way as the roads and streams.

114. **Measurement of the Trees.**—The strip method may be used without calipering the trees, but by counting them or estimating the contents of each merchantable tree as it is inspected. Usually, however, the trees are calipered at breast-height to the nearest inch. Sometimes the trees are thrown into diameter classes of two or more inches. Ordinarily only one measurement of each tree is taken unless it is obviously eccentric, when two diameters at right angles are measured, the average being recorded as the diameter. (See section 43.) Care should be exercised not to take the measurements below breast-height. It is very easy for a tired man to drop his calipers and measure at 3 or $3\frac{1}{2}$ feet instead of $4\frac{1}{2}$ feet. The author has made tests of the possible error occasioned by low measurements. With small timber averaging 6 to 10 inches in diameter the error is practically negligible, but with large timber it may seriously affect an estimate. In old spruce, the writer found that careless calipering adds 1 inch to the diameters of 20 percent of the trees. This means for every 1000 trees an overestimate of 8000 feet, or on an average, on spruce and hardwood lands, about 300 feet per acre. Care should also be exercised to place the calipers at right angles to the axis of the tree. It is obvious that a considerable error may result if the calipers are placed obliquely on the trunk. When there is a bulge or other normal swelling at breast-height the measurement should be taken just above the obstruction. In tropical countries, where many of the trees have buttresses, the measurements cannot be taken at breast-height, but special methods of grouping are used.

Where an estimate of merchantable timber is being made, only the apparently sound marketable trees are included. Errors in estimating often come from counting unsound trees. Inexperienced or careless men often measure trees which at first sight appear sound and merchantable, but which are really defective. Great care must be exercised to scrutinize each tree for signs of defect. Usually decay manifests itself by some external sign, as punk knots, white resin, unhealthy crown,

broken top, dead limbs, moss, and so on. A cruiser must know these signs. If he is working in a new country he should associate with him some local woodsman who is familiar with the character of the timber. In a great deal of government work trees below the merchantable size and sound trees of species not yet merchantable are measured in connection with preparation of working-plans. The principles governing the measurement of small trees is discussed on page 335.

The methods of determining the volume of the trees on the strip surveys are described in later sections.

115. Recording the Measurements.—The diameter measurements are recorded in a note-book or on a special tally-sheet. The tally-sheet is ruled in columns, the first showing the diameter classes, by inches or groups of two or more inches, the other columns being for the different species of trees. A special form of tally-sheet is used by the U. S. Forest Service, with columns sufficiently broad for subdivision. These tally-sheets may be fastened to a thin board by thumb tacks or carried in a special holder, made to contain approximately fifty sheets. This device is tray-like in form, and consists of a rectangular board or panel provided on three sides of its upper face with wooden cleats, the inner edges of which are grooved to receive the edges of the sheets, which are held in place by a narrow hinged leaf secured on its fourth side. A spring hook holds the leaf in its closed position. These holders may be purchased from Keuffel & Esser Co., New York.

The trees are tallied by dots and lines, in blocks of ten, as indicated in the following table, which shows the marks corresponding to different numbers:

1	2	3	4	5	6	7	8	9	10
•	••	•• •	•• ••	—• ••	—• ••	—• —•	□	□ /	□ / \

This method is economical of space, and enables the recording of a large number of trees on a single sheet.

116. Number of Strip Surveys Required for an Estimate.—It is the usual aim to make the sample strips comprise from 5 to 10 percent of the total area. Sometimes it is possible to include

20 or 30 percent, but ordinarily on large tracts, from 5 to 10 percent. is considered sufficient. On very large areas of 100,000 or 200,000 acres the strips cover 2 to 3 percent. Recent work in the U. S. Forest Service has been done on a basis of running the strips one-quarter or one-half of a mile apart.

Under ordinary circumstances a crew of four men should be able to measure off 30 to 50 acres a day if only the merchantable timber is included. In very open woods this number may be increased. Where small trees are measured and special care taken in laying off the strips, 20 acres a day are about all that a crew can measure.

117. Advantage of Strip Surveys.—The chief advantage of the strip method is that the sample acres represent a good average, inasmuch as they are run straight through the forest and include whatever may be in the course, whereas square plots are more apt to be located in the best areas and hence to give too large results. A second advantage is that the strip surveys may be taken very rapidly and a much larger number of sample areas obtained than is possible with carefully surveyed plots. The third advantage is that the systematic location of the strips enables the preparation of a map.

The disadvantage of the method is that there is always a chance of error in estimating the width of the strips. This is not a serious matter provided the calipermen are careful and the method is used only in measuring large timber. The estimating of the boundaries is hazardous in small timber, as an error of a few feet may result in including or excluding a considerable number of trees.

118. Accurate Plot Surveys.—Accurate plot surveys are used principally in the study of growth and the preparation of yield tables. Occasionally an accurately measured valuation area is used in timber estimating, but, if the merchantable trees alone are measured, rough valuation surveys like the strips and estimated plots described in the previous sections usually suffice.

Plot surveys are used in estimating small growth, as, for example, second-growth hardwoods in southern New England, birch

and poplar in Maine, etc. Rough plot surveys and strip surveys are unsatisfactory and unreliable in this small timber because a slight error in guessing at the boundary-lines of the rough valuation area often results in considerable errors in the estimate of the volume of the stand. Stands of small timber are usually more uniform than large and old timber and it is much easier to select plots which represent an average of the forest. For the same reason it is generally not necessary to take as many valuation surveys to secure a good average of a specified area and the plots need not be as large as in older and larger timber.

119. Instruments Used in Laying Off Sample Plots. — The sides are measured with a chain or tape and the angles with a small compass, staff head, angle mirror, or other instrument which is compact, light, and suited to rapid work. Instruments like the transit or railroad compass are not used in this work because great precision is not necessary and because these instruments are expensive, delicate, and difficult to carry in the forest. In the following sections the common instruments for measuring angles of sample plots are described.

Of these instruments the compass is best where the ground is very irregular, and where frequent offsets have to be taken to avoid trees or other obstructions. Under ordinary conditions the staff-head is the most satisfactory, especially for plots of half an acre or more. For quarter-acre plots or smaller ones the angle mirror is most rapid. The compass and staff-head have the disadvantage of being more clumsy than the angle mirror and of requiring a staff or tripod. Ordinarily, however, where accuracy requires the larger instruments, the extra trouble of carrying them is a small consideration.

Staff Compass. — This instrument (shown in Fig. 40) consists of a compass set into a shallow, circular metal box, having two sights hinged to its edge. A removable support, screwed into the bottom of the box, terminates in a socket, adapting the instrument to be mounted upon a staff or upon a tripod. The support also comprises a ball-and-socket joint, by which

the compass is leveled with the aid of spirit-tubes located in its bed, a swivel, which permits the compass to be turned in sighting it, and a set-screw for securing it against turning after sighting. When not in use the sights are folded down and the support unscrewed from the box. When taken apart the entire

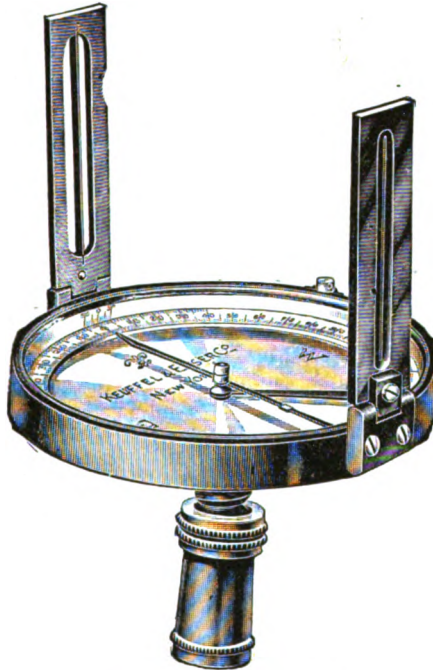

FIG. 40.—Staff Compass.

instrument is in compact form for transportation. It is made in different sizes, with needles from $2\frac{1}{2}$ to 4 inches long. The price varies from \$10.50 to \$13; without spirit-tubes, from \$8 to \$11.50.

Cross Staff-head.—This instrument consists of a small metal box, octagonal in form, mounted on a socket which may be fitted to a staff or tripod. Four of the faces have simple dioptric slits;

each other face has a short narrow slit to serve as the ocular, and a wide slit fitted with a hair as an objective. The socket may be unscrewed and fitted in the head for compactness in transportation. In use the staff-head, mounted on a staff or tripod, is placed on a known line, at a point where it is desired to lay off a new line at right angles to the first. A sight is taken along the known line and then without moving the instrument the observer uses the line of sight perpendicular to the first and determines the direction of the second line. This instrument may be purchased from Keuffel & Esser Co., N. Y., for \$4.

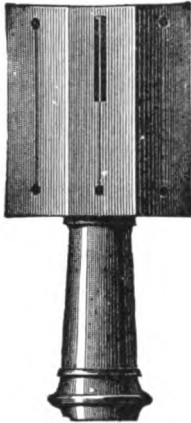

FIG. 41.—Cross Staff-head.

A handy staff-head is manufactured in Germany. It is cylindrical instead of octagonal and revolves in a metal rim, which is graduated in degrees, enabling the measurement of any angle. This instrument may be purchased for 30 marks from W. Spörhase, Giessen, Germany.

Other simple instruments based on the same principle as the staff-head are manufactured, such as the surveyor's cross. It is possible to manufacture a rough surveyor's cross by fastening two narrow strips of wood together at right angles and driving short nails near the ends to serve as the ocular and objective. This mounted on a staff serves well to measure right-angles.

The Angle Mirror.—This handy instrument consists of an open triangular metal box containing two small mirrors mounted in frames secured to the sides of the box and set at an angle of 45° to each other. Rectangular sight-openings are formed above the mirrors in the sides of the box. The device is provided with a handle, preferably made re-



FIG. 42.—Angle Mirror.

movable for convenience. The observer looks directly into the box through its open sides and sights the instrument through one or the other of its two sight-openings at some given object. At the same time an object at a right-angle to the object sighted is visible to him in the mirror below the sight-opening through which he is looking, and is in the same vertical line as the object sighted. The principle of the device is that the reflected object is first imaged through the open side of the box in the mirror opposite the sight-opening through which the observer is looking and then reflected across from one mirror to the other and thus brought into his vision.

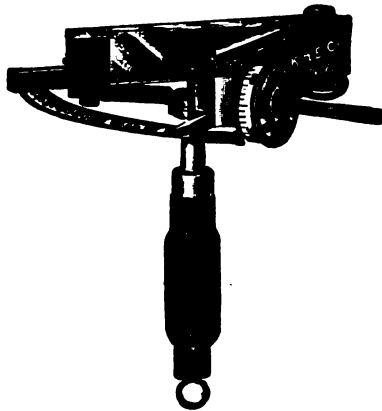

FIG. 43.—Adjustable Angle Mirror.

In laying off a square, the forester runs out one side and then takes a position at the point where he wishes to determine a right-angle. With the instrument in one hand he looks through one of its sight-openings at an object in the predetermined line, such as stake or pole. An assistant in the approximate location of the desired new line now moves about until his image appears in the mirror below the sight-opening being used, and exactly in line with the stake or pole. The assistant is then standing in a line at a right-angle to the predetermined line and establishes the new line.

An adjustable form of the angle mirror is shown in Fig. 43. One of the mirrors is movable and the inclination is determined by an arc graduated from zero to 100° . The instrument may, therefore, be set to determine any desired angle. It is of special value in running out irregular plots.

Determination of Right-angles with a Tape.—A right-angle may be determined with a tape. Suppose that a stake has been set on a predetermined line at a point where a corner is to be established, set a second stake 4 feet from the first stake on the line already established, determine the general direction of the required new line, and set a third stake which is exactly 3 feet from the first or corner stake and 5 feet from the second stake. A line of sight from the corner over this last stake will establish the new line exactly perpendicular to the first line.

Use of a Pocket Compass.—A square plot may be roughly laid out with a pocket compass, but usually where plot surveys are used greater accuracy is required than is possible with a pocket compass. A good compass for general forest use is the D. W. Brunton compass which is manufactured by Wm. Ainsworth of Denver, Colo. The instrument which carries a 3-inch needle is very strong and is fitted with a stout cover. The instrument is fitted with a line of sight, and the observer is able by means of the mirror in the lid to take a sight and the compass reading without removing the instrument from the eye. A clinometer attachment enables the determination of slopes, heights of trees, etc.

120. Necessary Precision in Laying Off Sample Plots.—The plots are surveyed off accurately. In practice, however, it is difficult, with such instruments as have been described for determining the angles, to lay off a plot with such precision as is required in most work of land-surveying. In an open forest of old trees a slight error in determining an angle or measuring a line may not be serious, but in small growth where the trees stand very close together such a mistake may result in including or excluding a large number of trees which in reality are

outside or inside the plot respectively. Where the forest is open and the plot covers as much as an acre, an error of 2 feet in tying up the lines may ordinarily be allowed. On all small plots, and if there is considerable small growth to be counted, on all large plots, an error of not over 6 inches may be allowed.

121. Shape and Size of Sample Plots.—Accurate plots are generally square or rectangular in shape. In some cases irregular polygons are laid off, as, for example, where it is desired to determine the volume of a specific patch of timber. The shape of the plot is not of so much importance as the knowledge of its exact area. As a rule acute angles in plots are to be avoided. Triangles are therefore not as good as polygons with wider angles. When possible, plots of one acre or multiples of one acre are laid off, because a smaller area does not give as good an average and because the final results are always expressed in acre terms. Nevertheless half-acre plots are used a great deal where it is inconvenient to lay off a whole acre, where a half acre represents better the required average conditions, or where a stand is very uniform. In very small timber and where the timber is exceptionally uniform, quarter acres are frequently used.

In estimating cord-wood, the author has successfully used plots 52 feet square, which comprise an area of one-sixteenth of an acre. A sixteenth-acre plot may be run out very rapidly and accurately with a 50-foot tape and angle mirror, and a short time only is required to measure the trees. Sometimes in small timber, where the forest types or ages of the stands vary considerably on a relatively small area, eight or ten sixteenth-acre plots give better results than one or two large surveys, such as could be obtained in the same length of time as the eight or ten small ones.

122. Marking the Boundaries of Sample Plots.—In laying off a plot the boundaries should be clearly marked, so that no trees outside the line will be measured nor any inside the plot be omitted. Stakes are set at the corners and a number of trees

along the lines are blazed. A good method of marking the boundaries is to lay string along the lines.

123. Calipering.—When the boundaries have been marked off, the trees are calipered. In calipering, a crew of three proceeds as follows: One man records the figures, the other two measure the trees, working over the plot in strips about 50 to 75 feet broad. The calipermen mark enough trees to enable them to follow the line back, and to prevent measuring any trees twice. Ordinarily it requires about $\frac{1}{2}$ to 1 hour to run out an acre and about $\frac{1}{2}$ hour to do the calipering if only merchantable trees are measured. If small growth is counted or measured a longer time is required to caliper a full acre.

The description just given applies to a crew of three men, which is the most convenient number. If there are two men, one records the figures and the other calipers the trees, moving back and forth over the area in narrow strips. The tallyman assists in keeping the strips uniform and the count accurate.

Scratchers (or as they are also called bark-blazers, tree-scribes gouge-blazes) are used by the calipermen for marking the trees. Several forms of scratchers are shown in Fig. 44. Scratchers may be purchased in Europe at a cost of from 50 cents to \$1 each. The European instruments, however, are too small and weak for use in old timber or with trees having hard bark like the hickory. A blacksmith of ordinary skill can make a satisfactory scratcher. An important consideration in making a scratcher, is to set the gouge at the proper angle to the axis of the instrument. The gouge should be about $\frac{1}{2}$ inch across at its widest point. A band of metal over the handle, as shown in most of the scratchers in Fig. 44, is important to protect the knuckles from the bark.

124. The Location of Sample Plots.—Sample plots are selected to represent an average of a larger area. The selection of the sample plots depends on the object of the investigation, the form, age, composition, and degree of uniformity of the forest, and the character of the land. The location of plots

depends, therefore, on judgment and not on rule. Some guiding principles may, however, be given which will assist the beginner. Two problems may be distinguished when plots are used in estimating.

1. The plots are to be used as a check to an ocular estimate, as, for example, in making compartment descriptions in a working-plan. In this case the plots are located wherever the estimator is in doubt as to the yield per acre. If more than one type of forest occurs, or there is a difference in age or character

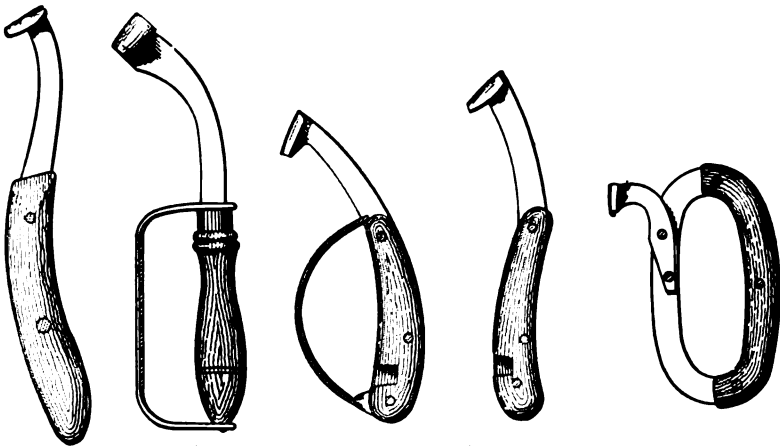

FIG. 44.—Different Types of Scratchers.

of the forest, one or more plots are laid off in each stand and used as a standard for comparison. Each stand must, however, first be carefully examined, in order that the estimator may select thoroughly representative plots.

2. An estimate is to be based entirely on the valuation surveys. Suppose that a tract of 1000 acres in southern New England is to be estimated, that there is considerable variation in the topography and the forest types, age, density of stands, etc. The estimator determines first how many plots are necessary and in general how they are to be distributed. The number is determined by considerations of expense and required accuracy. The general distribution is determined by the impression obtained

from a reconnaissance of the tract, for which not over one day would be required. Beginning at one end the estimator sketches on a map the boundary of a restricted area, as, for example, a slope, a swamp, a ravine, or other well-defined area having a fairly uniform stand. One or more representative plots are used to compute the acre-yield of the area which is determined from the map. Then another arbitrarily restricted area is marked off on a map and estimated separately, and so on until the whole tract is covered. If there is no map, the forester estimates the approximate area occupied by each type of stand and then estimates the volume of each type separately by the use of representative plots located in different places and averaged together to give the average acre-yield. Suppose, for example, that it is estimated that on the 1000-acre tract 20 percent is mixed chestnut, oak, and other hardwoods 40 to 50 years old, growing on first-quality soil; 20 percent the same species, also 40 to 50 years old, on second-quality soil; 30 per cents wamp land, with red maple and other swamp trees 20 to 30 years old; and the rest old grown-up pasture land 20 to 50 years old. Suppose, further, that 50 sample acres, or 5 percent of the area, are to be taken. These are distributed over the tract proportionately among the different types. The largest number are taken in the irregular stands, while only a few need to be taken in the youngest and most uniform stands. All the surveys in the 40- to 50-year-old oak-chestnut type are averaged together and multiplied by the number of acres in the type, and in the same way each of the other types is estimated separately. A natural suggestion often made by students is to average together all the plots and multiply by the total area of the tract. This plan is good provided the plots have been proportionately distributed among the different types. But it is very difficult to make such a correct distribution, and one would also be prevented from taking a larger number of plots where most needed on account of the irregularity of the stand or for other reasons. If the forest is uniform over the entire tract, all plots

would be averaged together for the average acre-yield of the whole area.

The location of plots used for studies of growth and for the preparation of yield tables is explained in Chapter XVII.

125. Computation of Volume of the Trees on Valuation Areas.—The volume of the trees measured in the surveys is determined from volume tables or by means of felled sample trees. In strip surveys the volume is usually computed from volume tables which show the contents of trees of different diameters. (See page 159.) This computation may be made very simply and rapidly in the following way:

Make four columns of figures as shown below. In the first column place the diameters, in the second column the number of trees of each diameter measured on the acre, in the third column the average contents of trees of different diameters, from the volume table, and in the fourth column the total contents of all trees of each diameter, which are found by multiplying together the values in the second and third columns. The figures in the fourth column are then added together for the total contents of the stand.

CONTENTS OF CHESTNUT ON A SAMPLE PLOT AT MILFORD, PENN.

Diameter, Breast-high, Inches.	Number of Trees.	Contents from Volume Tables, Cubic Feet.	Total Contents, Cubic Feet.
6	2	2.7	5.4
7	10	5.4	54.0
8	13	6.9	89.7
9	16	9.3	148.8
10	15	11.7	175.5
11	14	14.4	201.6
12	18	17.1	307.8
13	9	20.2	181.8
14	3	23.4	70.2
15	1	27.0	27.0
		Total	1261.8

If the contents of trees on the valuation areas are to be computed by the use of volume tables which are based on diameters and heights, it is necessary in the field to determine the heights as well as the diameters of the trees (See page 166). Usually the heights of a few representative trees of different diameters are determined and the heights of the trees of other diameters estimated by interpolation. Thus the heights of three to ten trees of each species are determined, care being taken to select trees of different diameters, including small, medium, and large trees. Care is taken to select for measurement trees each of which appears to be of about an average height in its particular class. Suppose, for example, that the following measurements of white pine have been taken:

Diameter in inches	10	15	19	24
Height in feet	75	85	93	114

With these data a height curve for trees of different diameters may be made. In a system of rectangular coordinates in which the abscissæ represent diameters and the ordinates represent heights, plot the four heights given above, then draw a regular curve through or as near the points as possible. The height corresponding to any diameter may then be read off from this curve.

This method is used to find the contents of a valuation survey in the following way: Make a table of five columns. In the first column place the diameters; in the second column, the number of trees of each diameter given in the first column; in the third column, the average height of trees of each diameter, these average heights being obtained from a curve such as has been described; in the fourth column, the contents of an average tree from a volume table; in the fifth column, the total contents of all trees of each diameter; then add the figures in the fifth column and the result will be the total contents of the stand. The following is an example of such a table:

WHITE PINE.

Diameter Breast-high, Inches.	Number of Trees.	Height, Feet.	Contents of Average Tree from Volume Table, Board Feet.	Total Contents, Board Feet.
10	10	75	30	300
12	11	78	69	759
14	3	82	120	360
16	4	86	185	740
18	4	91	272	1088
20	5	97	383	1915
22	2	105	549	1098
				6260

In some investigations a calculation of heights for every valuation survey is made. In this case a separate crew of two men accompany those taking the survey and measure the necessary heights. More often in strip surveys the average heights of trees of different diameters are obtained for different forest types or for specified portions of a tract and used in applying the volume tables to all the valuation surveys in those types or specified areas.

Sometimes the height of each tree is estimated when the diameter is measured. The trees are then recorded by diameters and by height classes, the tally-sheet being specially ruled like the following form:

Diameter, Breast-high Inches.	White Pine.			
	Height Classes.			
	20-30	30-40	40-50	50-60

The volumes are computed by using a volume table for trees of different heights and diameters.

Instead of grouping the trees by diameters and heights, it is possible to group them by diameters and merchantable lengths. The application of this method is almost exactly like that just described. The diameters are first measured, and then the average merchantable lengths of trees of all diameters determined from the measurement of a few trees and interpolation by a curve; or the merchantable length of each tree is estimated when the diameter is taken. In the last case the measurements are recorded on a tally-sheet ruled like the following:

Diameter. Breast- high, Inches.	White Pine.										
	Merchantable Length in Feet.										
	10	12	14	16	18	20	24	28	32	36	40

The volume table, like that described on page 164, is used to compute the contents of the stand.

If volume tables based on diameters and number of logs are used in computing the contents of timber on the valuation areas, the field work must include the determination of the number of logs as well as the diameters of the trees. The simplest way is first to measure the diameters as ordinarily and estimate the average number of logs in a few representative trees of different sizes, and then by interpolation estimate the number of logs in trees of any desired diameter, just as (explained on page 220) is done with heights. Usually it is sufficient to determine the average number of logs for separate forest types on specified portions of a tract and use this average for all plots within that type or area. Knowing the number of trees of each diameter and the average number of logs in each tree, the volume of an acre may easily be calculated from the volume table.

If specially accurate results are required, the calipermen give not only the diameter and species, but also the number of logs of each tree. The tally-sheet is ruled in the following way for the record of the measurements:

Diameter, Breast-high, Inches.	White Pine.				Hemlock.		Etc.
	One-log Trees.	Two-log Trees.	Three-log Trees.	Four-log Trees.	One-log Trees.	Two-log Trees.	

The volume table may then be used to compute the contents of the valuation survey.

Some investigations require a separation of the trees into special classes. Thus in some of the valuation survey work by the Government the dominant, intermediate, and suppressed trees have been recorded separately. With second-growth hardwoods it is often desirable to separate the trees into three or more classes, which are usually based on crown development. In such cases the volume of the trees calipered, is determined by using a volume table which shows the contents of trees of different diameters and tree classes. (See page 164.) The field data are recorded on a tally-sheet ruled like the following:

Diameter, Breast- high, Inches.	White Oak.					Chestnut.		
	Class I.	Class II.	Class III.	Class IV.	Class V.	Class I.	Class II.	Etc.

It may happen that the volume is desired, not in cubic feet or board feet alone, but in special products. Thus it may be desired to note the number of poles, ties, posts, or mine timbers

of certain dimensions. In this case a special ruling of the tally-sheet must be made. Sometimes merely the number of poles is indicated; at other times the diameter of the tree which yields 1 tie, 2 ties, 3 ties, etc., is shown. In work in second-growth hardwood forests where the computation of the cord-wood left after taking out the ties is desired, it is necessary to note the diameter of the trees as well as the number of ties. A form like the following may be used:

Diameter, Breast- high, Inches.	Chestnut.							
	One Log.	Two Logs.	Three Logs.	Pole.	One Tie.	Two Ties.	Three Ties.	Cord- wood.

The total amount of cord-wood is determined from volume tables which show the contents, in cords, of trees of different sizes and which show also the cord-wood left after taking from trees of different sizes a pole or a specified number of logs or ties.

126. Determination of Volume of Stands by the Use of Felled Sample Trees.—The volume of the trees on a given sample plot may be determined by the use of volume tables in the way described above. But if no reliable volume tables exist, or if very accurate results are required, it is necessary to fell and measure a certain number of sample trees and from them calculate the volume of the whole stand. A number of different methods of computing the volume of stands by means of sample trees have been devised. The methods likely to be of special interest to American foresters are described in the following pages.

127. The Mean Sample-tree Method.—The principle of this method is to caliper the trees on a given plot, then determine the diameter of the average tree, fell and measure test trees having this average diameter, determine their contents, and from them estimate the contents of the whole stand.

As explained later this method is not applicable to the board-foot unit, but to the volume units like the cubic foot and cord. In practical work in the United States it is most used for computing the contents of second-growth timber in cubic feet and cords.

Determination of the Diameter of the Average Tree.—There are several conceptions of the average tree and the ways to determine its dimensions.

One way is to determine the arithmetic mean of the diameters represented in the stand. Each diameter is multiplied by the number of trees of that size and the sum of the products divided by the total number of trees in the stand. Expressed algebraically,

$$\text{Average diameter} = \frac{d_1 n_1 + d_2 n_2 + d_3 n_3 + \dots + d_x n_x}{N},$$

where d_1 is the smallest diameter measured in inches and n_1 is the number of trees of that size, d_2 is the next inch-diameter and n_2 the number of trees, and so on; and N is the total number of trees.

It has been explained that the principle of the mean sample-tree method is to determine the average tree and then obtain the whole volume of the stand by multiplying this average tree by the total number of trees represented. In other words, the average tree is the tree of an average volume, and if the arithmetic average diameter is determined as just described, it is assumed that the contents of trees vary as their diameters. The contents of trees do not vary as their diameters, but more nearly as the squares of their diameters. The diameter of the average tree is, therefore, more accurately determined by computing the average basal area of the stand and from this the corresponding diameter. The average basal area is obtained by the formula

$$B = \frac{b_1 n_1 + b_2 n_2 + b_3 n_3 + \dots + b_n n_x}{N},$$

in which B is the average basal area, b_1, b_2, b_3 , etc., are the areas of circles of different diameters.

If v_1, v_2, v_3 , etc., are the volumes, n_1, n_2, n_3 , etc., the number of trees, h_1, h_2, h_3 , etc., the heights, f_1, f_2, f_3 , etc., the form factors, and b_1, b_2, b_3 , etc., the basal areas of the trees of different diameters; and v, b, h, f are the volume, basal area, height of the average tree, and N the number of trees on the given area, then

$$V = \frac{v_1 n_1 + v_2 n_2 + v_3 n_3 + \dots + v_x n_x}{N}$$

and

$$bhf = \frac{b_1 h_1 f_1 n_1 + b_2 h_2 f_2 n_2 + b_3 h_3 f_3 n_3 + \dots + b_x h_x f_x n_x}{N}$$

In even-aged stands, provided there is not too great a range of diameters $hf = h_1 f_1 = h_2 f_2 = h_3 f_3 = h_x f_x$, and then the above equation becomes

$$B = \frac{b_1 n_1 + b_2 n_2 + b_3 n_3 + \dots + b_x n_x}{N}$$

If there is a very wide range in the diameters of the trees on an area, then the products of the form factor and height in the different diameter classes are not equal, and the volumes do not vary as the basal areas. In this case the mean sample-tree method is not applicable.

The calculation of the average basal area is simplified by tables which give the product of areas of circles and different numbers such as are likely to be met in the field. (See page 430.) After calipering the trees on a given plot one uses this table to obtain the product of the area and number of trees of each inch-diameter class, then adding these products divides by the total number of trees. The result is the average basal area, and the corresponding diameter is easily determined from a table of areas of circles.

Selection of Test Trees.—When the average basal area and the corresponding diameter have been determined, the test trees are selected, felled, and measured. The forester endeavors to find trees within a half inch of the ideal size. He chooses *average trees*; that is, those which have an average crown develop-

ment and normal trunk form. No rules can be laid down for this selection. The forester judges entirely by the eye after inspecting the stand, which presumably has been done during the calipering. The amateur nearly always selects the best trees of the required diameter. Normal and average do not mean the tallest, straightest, roundest, and fullest boled trees. Herein lies the greatest drawback of the method. Inexperienced or careless men are apt to overestimate the stand by selecting abnormally good trees as average. The method is more easily applied and more accurate when trees are even-aged and fairly uniform and the variation in height is not great.

Number of Test Trees Required.—This depends on the character of the forest and nature of the investigation. Ordinarily 3 to 5 test trees of a given species are considered sufficient for work in a fairly uniform stand. In an extremely accurate investigation this method would not be used at all.

Computation of Results.—The volumes of all the test trees are first determined and averaged together. If the basal area of each is exactly the same as the average basal area in the stand, the product of the average volume of the test trees by the total number of trees in the stand gives the total volume. If, however, the basal areas of the test trees are not exactly the same as the average basal area in the stand, the total volume is obtained by the following formula, which corrects the slight error caused by using the volumes of test trees whose basal areas are not exactly equal to the average basal area in the stand:

$$V:v=B:b \quad \text{or} \quad V=\frac{v \times B}{b},$$

in which V is the desired volume of the stand, v is the average volume of the felled test trees, B is the total basal area of the stand, and b the average basal area of the test trees.

Problems in which the Method will be Used.—This method will be used chiefly in estimating the volume of small timber and uniform stands. Where the range of diameters is very

small it may be used in the preparation of yield tables in cubic feet. It is not accurate in irregular stands where there are large differences in the diameters and tree classes. It is inapplicable to board measure, but in the study of cord-wood it finds a very practical use. In second-growth hardwoods the stands are often relatively even-aged and the difference in diameter of the merchantable trees of a single species not great. This is particularly true in young stands. In very irregular stands it is necessary to make diameter groups as in the methods described in the succeeding sections.

The mean sample-tree method is shown in the following computation of 336 spruce trees in the Adirondacks. The trees were growing in a relatively even-aged stand, 100 to 130 years old, of spruce, mixed with scattering fir, birch, and maple. All trees on 14-sample plots were felled and analyzed, and of the total number, 336 were chosen at random for the computation by different methods. The actual contents of the trees, obtained by adding together the volumes computed individually, are 2150 cubic feet. The mean sample-tree method gives 2197.8 cubic feet.

COMPUTATION OF VOLUME OF A SPRUCE STAND BY THE MEAN SAMPLE-TREE METHOD.

Diameter, Inches.	Number of Trees.	Basal Area, Sq. Ft.	Average Basal Area, Sq. Ft.	Diameter Average Tree, Inches.	Diameter Test Trees, Inches.	Basal Area Test Trees, Inches.	Merchantable Volume Test Trees, Cu. Ft.					
5	15	2.040	0.384	8.4	8.5 8.4 8.4 8.5 8.2	0.394 0.385 0.385 0.394 0.367	6.90 6.67 6.32 6.98 5.94					
6	48	9.408										
7	77	20.559										
8	63	21.987										
9	50	22.100										
10	38	20.710										
11	31	20.460										
12	10	7.850										
13	3	2.766										
14	1	1.069										
Totals...	336	128.949								Totals...	1.925	32.81

$$V = \frac{32.81 \times 128.949}{1.925} = 2197.8 \text{ cubic feet.}$$

If one test tree, and in this case the first in the list, were used, the result would be

$$V = \frac{6.9 \times 128.949}{0.385} = 2311 \text{ cubic feet.}$$

If the first three trees were used as test trees, the result would be

$$V = \frac{19.89 \times 128.949}{1.155} = 2220.5 \text{ cubic feet.}$$

In this calculation the volume has been obtained by the formula for the sake of illustration. Usually when the basal area of the test trees are so nearly identical with the average basal area of the stand, the formula is not used, but the volume obtained by multiplying the average volume of the test trees by the number of trees in the stand. In the above example the average volume of the five test trees is 6.56 cubic feet. This multiplied by 336 is 2204.16.

128. Arbitrary Group Method.—If the trees in a given stand vary considerably in diameter, the mean sample-tree method is inaccurate, because of the difficulty in selecting average test trees in an irregular stand. More accurate results are obtained by grouping the trees into diameter classes and determining separately the volume of each class. The method has the advantage of greater accuracy than the preceding, because it enables the determination of the volume of different parts of the stand separately. Thus, for example, the volume of the merchantable trees and of those which are not merchantable may be determined separately. This method may be used to determine the contents of stands in board measure.

In the arbitrary group method the sizes of the different diameter groups are determined arbitrarily. There is no rule as to the number of inches to be included in each group and the different groups do not necessarily contain the same number of inches.

• Usually at least 3 inches are comprised in one group, although sometimes a group of 2 inches is used. Suppose that a second-growth stand of fir is calipered and all trees taken; suppose, also, that trees under 6 inches are salable for cord-wood and that no trees under 10 inches will yield merchantable boards; then the trees under 6 inches are included in the first group, those 6 to 10 inches in the second separate group, and above this each 4 inches are taken as a separate group, unless there are only a few trees of the larger diameters when one wide group of 5 or more inches is made. After fixing the groups, the diameter of the average tree in each group is determined exactly as the diameter of the average tree was determined for the whole stand in the preceding method. The principle of selection of the test trees is the same as in the preceding method, namely, to find trees of the required diameters, each having an average form and average height of its class. A good way is to select for inspection a number of trees of the desired diameter and compare their height and form and then from these make the final selection for felling.

Frequently satisfactory test trees of the desired diameters cannot be found on the sample plot under examination. In this case one may use test trees which are growing just off the plot provided the conditions of growth are the same as on the plot. A good test tree off the plot is better than a poor one on the plot. Test trees cannot be selected offhand. The writer has seen young foresters choose as average trees, and as representatives of the same class, specimens which proved to differ in volume 20 percent. A careful scrutiny and comparison of the trees before felling would have shown the difference and prevented a bad selection.

Ordinarily three trees of each diameter group are considered enough even where very accurate results are required. In many investigations one tree for each group is sufficient. If the data are for the study of volume growth and for yield tables, the forester should cut, when possible, three trees for each group of over

20 trees, 2 for groups containing 10 to 20 trees, and 1 tree for groups of less than 10 trees.

When the trees have been measured and later in the office he volumes ascertained, the contents of the whole stand are determined. The volume of each diameter group is computed separately and then the results added together for the total volume of the stand.

In most work, as when the board-foot unit is used, the average volume of the test trees is multiplied by the number of trees in the group. In exact work with cubic feet the formula described in section 127 is used, viz., $V:v=B:b$, in which V and B are the volume and area of the group and v and b are the average volume and area of the test trees.

COMPUTATION OF VOLUME OF A SPRUCE STAND BY THE ARBITRARY GROUP METHOD.

Diameter, Inches.	Number of Trees.	Basal Area, Sq. Ft.	Number of Group	Number of Trees in Group.	Basal Area of Group, Sq. Ft.	Basal Area Av. Tree, Sq. Ft.	Diam. Average Tree, Inches.	Diameter Test Trees, Inches.	Basal Area Test Trees, Sq. Ft.	Merchantable Volume Test Trees, Cu. Ft.
5	15	2040	I	140	32.007	0.229	6.5	6.2	0.210	2.47
6	48	9408						6.4	0.223	2.43
7	77	20559						Total	0.433	4.90
8	63	21987	II	151	64.797	0.429	8.9	8.7	0.413	8.31
9	50	22100						9.0	0.432	7.88
10	38	20710						Total	0.845	16.19
11	31	20460	III	45	32.145	0.714	11.4	11.6	0.734	12.29
12	10	7850						11.7	0.747	15.12
13	3	2766						Total	1.481	27.41
14	1	1069								

$$v_1 = \frac{4.9 \times 32.007}{433} = 362.2$$

$$v_2 = \frac{16.19 \times 64.797}{845} = 1241.5$$

$$v_3 = \frac{27.41 \times 32.145}{1.481} = 594.9$$

Total = 2198.6 cubic feet

129. The Volume-curve Method.*—This method consists in constructing for each sample plot a volume curve, on a basis of the breast-height diameters, from the measurements of selected test trees, and in making from this curve a volume table to compute the contents of the plot.

After the trees on the given plot have been calipered, a number of test trees are selected for felling. It is not necessary, as in the methods just described, that the test trees have certain specified diameters, but the forester chooses some small trees, some large ones, and some of medium size. After the calipering, the required number of test trees and the method of their selection are fixed upon. If the trees in the stand are mostly of medium size, more test trees are apportioned to the medium diameters than any others, but representatives of the small and of the large trees must also be included. Each test tree must have a normal form and height; that is, must be a fair average tree of its class. Thus a 10-inch test tree must have a form and height as nearly representative of the average of 10-inch trees as can be judged by the eye. The test trees are then felled and measured for volume. There must be at least three test trees for each plot, even in rough work. In accurate work of preparing yield tables 6 to 10 trees should be taken. The test trees are felled and measured for volume in the ordinary way. They are used in computing the volume of the stand in the following way: The volume of each test tree is calculated and is then plotted on cross-section paper whose ordinates represent volume and abscissæ represent diameters. A regular volume curve is then drawn through the plotted points, from which may be read the average volume of trees of any diameter represented on the sample plot. In reality, a local volume table for the sample plot is made and may be used in calculating the

* The method was first proposed by Kopetzky in the *Zeitschrift für der gesamten Forstwesen* in 1891. Dr. Speidel in 1894 (*Allgemeine Forst- und Jagdzeitung*) proposed a slight modification, and since then the method has been called Speidel's Method.

volume of the stand exactly like the volume tables explained in section 125.

The advantages of the volume-curve method are: that it enables the computation of the volume of trees of each diameter separately and may, therefore, be correctly used with board measure; that field work is simple and rapid, no computing work in the woods being necessary; and that it is very accurate because each volume used in the computation depends on the values of all the test trees and hence any abnormal values are corrected, which is not the case in the arbitrary group and similar methods.

COMPUTATION OF THE VOLUME OF A SPRUCE STAND BY THE VOLUME-CURVE METHOD.

Diameter, Inches.	Number of Trees.	Diameter of Test Trees, Inches.	Volume of Test Trees, Cu. Ft.	Volume from Curve, Cu. Ft.	Volume of all Trees, Cu. Ft.
5	15	1.2	18.0
6	48	6.4	2.4	2.1	100.8
7	77	3.7	284.9
8	63	8.1	6.4	5.8	365.4
9	50	9.3	8.57	8.0	400.0
10	38	10.7	12.47	10.3	390.4
11	31	11.5	12.86	12.6	390.6
12	10	14.9	149.0
13	3	17.3	51.9
14	1	19.8	19.8
				Total	2070.8

130. **The Draudt Method.**—This method is often used in Europe in work requiring an accurate determination of the contents of stands. It is applicable only to research work where it is possible and desirable to fell a large number of test trees. It is used only with cubic measure.

In this method the number of test trees in each diameter class bears a constant ratio to the total number of trees in the class. Thus if it is decided that the number of test trees in a plot be 10 percent of the total number of trees standing on the

plot, the number of test trees in a given diameter class is 10 percent of the number of trees in that class. In theory the volume of all the test trees multiplied by the quotient of the total number of trees in the stand by the number of test trees gives the total volume of the stand; that is, if 10 percent of the individuals in a stand are felled and these felled trees are proportionately distributed among the different sizes, their total volume will be one-tenth of the volume of the stand. When, however, one attempts to determine the number of test trees of a single diameter or diameter class, it is very rare that the result will be a whole number, but is usually a fraction. If, for example, there are twenty-two trees in a group, 10 percent of them is two trees and two-tenths. If two trees are cut, their contents cannot represent the yield of two and two-tenths trees, but only of two trees. In practice the numbers are rounded off to whole trees, all fractions up to 0.5 being disregarded. It may happen then that several of the diameters have no representative test trees whatever. In this case it is sometimes customary to group together two or more diameters which have few trees represented, and to assign one test tree to the group.

This rounding off of the figures disturbs the perfect distribution of the test trees, and in this case the sum of the volumes of the test trees does not represent one-tenth the total volume of the stand. The total volume is, therefore, not determined by the formula $V:v=N:n$, but by the formula $V:v=B:b$, in which V is the total volume of the stand, v the sum of the volumes of the test trees, B the basal area of the stand, and b the sum of the basal areas of the test trees.

In practice the trees are calipered as usual, the percentage of the total number to be felled as test trees fixed upon, and the tally of calipering arranged as shown on page 237. The diameters are entered in the first column; the number of trees, in the second column; the basal areas of the trees, in the third column; in the fourth column, the product of the number of the trees by the percentage factor for determining the number

of test trees; and in the fifth column, the values of the fourth column rounded off to whole numbers. Column five is then inspected to see that the total number of trees is the correct percentage of the whole number on the plot. It often happens that in rounding off the figures in column five, the total number of trees is too large or too small. Exactly this thing occurred in the computation shown on page 237. A total of 12 instead of 13 trees, was obtained. Therefore 2.5 (column 3) opposite 8 inches was called 3 and 1.5 opposite 10 inches was called 1.

Test trees are then selected, and felled, and measured for volume. After computing the volumes of the test trees, the data obtained are entered in the form described above, the basal areas in the sixth, and volumes in the seventh columns. After adding the columns for totals, the volume of the stand is obtained by the formula $V:v=B:b$.

It may be desirable to use an arbitrary number of test trees rather than a specified percentage of the number of trees as test trees. Suppose, for example, that it is desired to cut 15 trees. If N is the total number of trees in the stand and n, n_1, n_2 , etc., the number of trees of each diameter, the number of test trees for any specified diameter x is $\frac{n_x \times 15}{N}$. The trees are arranged

in a form similar to that shown on page 237. In column 4 is entered for each diameter the value of the expression $\frac{n_x \times 15}{N}$.

As in the other case fractions will result. These fractions are rounded off to whole numbers in column 5. A larger number of diameters may be left without representation than in the other method. If among the larger or smaller diameters a considerable number are left without test trees, one or more groups are made to bring the total number of test trees up to 15. The method from this point is carried out exactly as before.

Another modification of Draudt's method is to make diameter groups on the same principle as in the arbitrary group method.

The diameter of the average tree is then determined for each group. The number of test trees is decided upon as a specified number or as a certain percentage of the total number in the stand and apportioned to the diameter groups. If 10 percent is chosen the number of test trees for each group is 10 percent of the total number of trees in that group. The required number of test trees for a given group are then felled, all of the same diameter as the average tree of the group. The method is carried through from this point exactly like the arbitrary group method. The only difference between this and the arbitrary group method is in the determination of the number of test trees for the different groups.

The Prussian Forest Experiment Station has adopted the following rule for making diameter groups: Four classes of 100 trees each are made of the 400 largest trees in a specified hectare plot; three classes of 200 each of the 600 next largest trees and if any trees remain they are grouped into classes of 400 each.

As the Draudt method is applied, all the material may be worked up together. When cord measure is used this is a great advantage, because it is impractical to make stacks where each test tree has to be kept separate. On the other hand, the method is very slow and laborious, involving a large amount of work on paper in the field and the felling of many test trees. The gain in accuracy is not sufficient to counterbalance this objection. The use of diameter groups simplifies the method and brings it within the range of most investigators.

131. The Urich Method.—The principle of this method is to divide the trees in a stand into a specified number of diameter groups, so arranged that each group contains the same number of trees. The test trees are then equally divided among the different diameter groups. By this plan test trees are distributed in correct proportion to different parts of the stand, whereas in the arbitrary group method a diameter group com-

prising 20 trees often has as many test trees as one comprising 80 trees.

COMPUTATION OF THE VOLUME OF A SPRUCE STAND BY THE DRAUDT METHOD.

Diameter, Inches.	Number of Trees.	Basal Area, Sq. Ft.	Percent. [- 4%] Multiplied by Number of Trees.	Number Rounded to Whole Trees.	Basal Area Test Trees, Sq. Ft.	Volume Test Trees, Cu. Ft.
5	15	2040	0.6	1	0.147	1.57
6	48	9408	1.9	2	0.419	4.66
7	77	20559	3.1	3	0.850	13.45
8	63	21987	2.5	3	1.119	19.47
9	50	22100	2.0	2	0.875	17.0
10	38	20710	1.5	1	0.579	9.97
11	31	20460	1.2	1	0.625	12.47
12	10	7850	0.4	0		
13	3	2766	0.1	0		
14	1	1069	0.04	0		
Totals.....	336	128949	13	4.614	78.59

$$v = \frac{78.59 \times 128.949}{4.614} = 2196.4.$$

After the calipering is completed, the total number of trees is first determined, and by inspection of the tally-sheet the necessary number of diameter groups fixed upon. The total number of trees in the stand divided by the number of groups gives the number of trees to be included in each diameter group. If the total number of trees is not exactly divisible by the number of groups it is necessary to assign one or two more trees to some groups than to others. The tally record is then transferred to a new sheet. Beginning with the smallest trees, the diameters and number of trees are entered as ordinarily, except that some inch classes are split in order to include in each group the correct number of trees. In the example given on page 237, it was necessary to split diameter inch class 7, and to include 49 trees of this size in the first part and 28 trees in the second part. The inch class 9 is split in the same way. After arranging the

diameter groups, the diameter of the average tree of each group is ascertained. A specified number of test trees for each group is then selected for felling and measurement. From this point on the computation is exactly the same as in the arbitrary group method.

This method is very accurate and has practically replaced Draudt's method in much of the scientific work in Europe. It has nearly all the advantages of Draudt's method and is much simpler and more rapid.

In practice 3 to 5 classes are usually made. The German Association of Forest Experiment Stations prescribes for yield-table studies a division of the stands in 5 groups and for each group 5 test trees. When extremely accurate results are required, 7 classes are sometimes made. For work in this country a good rule is to use such a number of groups that a single group among

COMPUTATION OF THE VOLUME OF A SPRUCE STAND BY THE URICH METHOD.

Diameter, Inches.	Number of Trees.	Total Number of Trees.	Basal Area, Sq. Ft.	Total Basal Area, Sq. Ft.	Average Basal Area, Sq. Ft.	Diameter Average Tree, Inches.	Diameter Test Trees, Inches.	Basal Area Test Trees, Sq. Ft.	Volume Test Trees, Inches.
5	15		2040						
6	48		9408				6.2	0.210	2.47
7	49	112	13083	24531	0.219	6.3	6.4	0.223	2.43
7	28		7476						
8	63		21987				8.1	0.376	6.74
9	21	112	9282	38745	0.343	7.9	8.0	0.349	6.84
9	29		12818						
10	38		20710						
11	31		20460						
12	10		7850						
13	3		2766				10.3	0.567	9.62
14	1	112	1069	65673	0.586	10.4	10.2	0.579	11.10
Totals.		336		128949				2.304	39.20

$$V = \frac{39.2 \times 128.949}{2.304} = 2194 \text{ cubic feet.}$$

the diameters best represented will not include over 4 inches. Ordinarily 3 test trees for each group is sufficient for the studies made under our present conditions, except in the work of permanent sample plots, when at least 5 test trees should be measured.

The advantages of Urich's method are that it is very accurate, because the test trees are proportionately distributed among the different diameters, and it permits of a separation of the classes of timber, as in the arbitrary group method.

The chief disadvantage is that a transfer of the field data to a new sheet and considerable other computation are necessary in the field before the test trees can be felled.

A modification of the method, also proposed by Urich, is to arrange the groups so that the most trees are included in the medium-sized diameter groups, to which a proportionately larger number of test trees are allotted. Suppose, for example, that there are 250 trees on the plot; that 10 test trees are to be felled, and an inspection of the tally record shows that the smallest number of trees are among the small diameters, and that the largest diameters are also poorly represented, though better than the smallest trees. Suppose, further, that four diameter classes are to be formed. Then the trees would be distributed in the different classes in the ratio 2:3:3:2. Since the total number of trees is 250, then $250 \div 10 = 25$, and the number of trees in each group would be 50:75:75:50.

The advantage of this plan is that the most important trees are grouped together and the less important are kept in separate groups.

Another slight modification of the method proposed by Urich is the following: After calipering the trees and arranging them in groups containing the same number of trees, the average diameter is estimated by inspection of the tally record; a uniform number of test trees are cut in each group, and from their volumes the total volume of the stand is calculated by the formula

$$\text{Total volume} = \frac{\text{Volume of all test trees} \times \text{total number of trees}}{\text{Number of test trees}}$$

Tests of this modification of Urich's method have shown a very high degree of accuracy when the number of diameter groups is large; that is, when the diameter range of each group is so small that the average tree may be easily estimated.

The object of the method is to save the time required to calculate by

basal areas the diameter of the average tree in each group. This saving of time is, however, extremely small, not over fifteen minutes on each plot. It seems to the author to be inconsistent to use an elaborate method of arranging the classes and a loose method of calculating the diameters of the sample trees.

132. Hartig's Method.—In this method the trees on a sample plot are arranged in such a way that all diameter groups have equal total basal areas. An equal number of test trees are then assigned to each diameter group. The method is designed to make diameter groups in which the volumes are about equal. In the other methods the total volumes of the groups differ widely. By the Hartig method the volumes are brought nearer together, but still are not always equal, because the heights of the trees in the separate classes are usually different. After the trees have been calipered, the tally record is examined to determine the number of groups to be formed. The data are entered from the tally record upon a new sheet. The total basal area of the whole stand is determined and divided by the number of diameter groups. The result of this division represents approximately the basal area which each diameter group should have.

In forming the diameter groups one begins with the smallest diameters and adds together the corresponding basal areas until the sum is approximately the same as the quotient of the total basal areas by the number of classes. It is usually necessary to split certain diameters in order to approach this figure, just as it was necessary to split diameters in Ulrich's method. A specified number of trees of each group are then selected for felling and the computation of final results is carried out as in the arbitrary group method.

133. Block's Method.—This method is peculiar only in the manner of forming the diameter groups. After calipering, the trees are arranged in diameter groups, usually of 50 trees each, beginning with the largest. The last group may contain less than 50 trees. If there are over 500 trees on the plot, classes of 100 trees each are made. The average diameter of each group is then computed and at least one test tree cut for each.

134. Method of Forest Form Factor.—The total volume of a stand in cubic feet may be obtained from the product of the total basal area of all the trees, the average height of the stand and an average form factor, called the forest form factor. The forest form factor is calculated by the formula

$$F = \frac{V}{BH},$$

in which V is the volume, B the total basal area, and H the average height of the stand. With such tables in hand, the contents of a sample plot may be readily obtained in the following way: First caliper the trees to ascertain the total basal area, then measure (with height measure) or estimate the average height, and then multiply the product of the total basal area and average height by the average form factor, shown in the table, for the given species and character of forest. One way to determine the forest form factor is to use the average of the form factors of the individual test trees. Since the form factor is an expression of volume, the form factor of the average tree of the stand is approximately the forest form factor. If, therefore, forest form factors are not available, the average tree of a stand is determined; representatives are felled and their form factors computed, averaged, and used as the forest form factor to calculate total volume of the stand. Instead of felling test trees, the form factor of the average tree, taken from a form-factor table, is sometimes used as a forest form factor. This is, however, really another form of the mean sample-tree method.

Studies in Europe have shown that the average tree—that is, the tree having an average volume, form factor, and height—in an even-aged stand is so related to the others that 60% are smaller and 40% are larger. To find the diameter of the average tree, therefore, one may count off 40% of the trees in the tally record beginning with the largest. This average tree is used as described in the two previous paragraphs.

A modification of the method just described is that involving the use of the form height. In section 98 it was explained that the expression form height refers to the product of the form factor and height of a tree. The forest form height of a stand may be found by multiplying the forest form factor by the average height of the stand. In Europe average form-height tables are often constructed. With such tables at hand the volume of the trees on a plot is computed as follows: The total basal area is determined by calipering; the average height of the stand is then determined with a height measure or by estimate; and the total volume of the stand is obtained by multiplying the total basal area by the form height given in the table corresponding to the average height of the stand.

135. Metzger's Method.—This method is sometimes used in Denmark for estimating timber. It is applicable to stands which are even-aged or nearly

so, mature or nearly mature, and which have been properly thinned; in other words, to timber tracts of even-aged stands which have been under forest management. Such forests occur abundantly in Europe, but the method cannot be used for estimating in this country because of the irregularity of our stands. Applied to the spruce stand mentioned with the preceding methods, a total volume of 2506 cubic feet was obtained, or 17% too much. Briefly the method is to take a block of forest (not necessarily a sample plot, but any specified area) and count the trees. As the trees are enumerated the forester keeps in mind the general run of their sizes, but does not measure them. After counting, the forester, who from his observation knows about how the sizes run, selects for felling and measurement of volume three of the largest and seven of the smallest trees. The volume of the stand is then obtained by the following formula:

$$V = N \times \frac{\text{vol. 3 max.} + \text{vol. 7 min.}}{10}.$$

In other words, the volume of the stand is equal to the total number of trees multiplied by one-tenth the sum of the volume of three maximum and seven minimum test trees.

136. Method of Absolute Form Factor.—The principle of this method is to determine separately the contents of the portions of the trees above breast-height and then add the contents of the portions between this point and the stump. In the first part of the computation breast-height is considered the base of all trees just as if a plane were passed through the stand at that point and as if the butts of the trees below this imaginary plane did not exist. After the contents of the trees above breast-height have been ascertained, the contents of the butts are computed and added to the first result for the total volume of the stand.

The volume above breast-height is obtained by an average absolute form factor in the following way:

If V is the volume, H the height of the average tree above breast-height, and B the basal area, the absolute form factor of the upper portion of the tree is obtained from the formula

$$V = FBH \quad \text{or} \quad F = \frac{V}{BH}.$$

The total volume of a stand (above breast-height) may be obtained by multiplying the product of the total basal area and the average height (above breast-height) by the average absolute form factor as defined above.

The portion of the average tree below breast-height is treated as a cylinder. If its length is designated as S , then its volume is the product of S and B .

In computing the volume of a stand it is assumed that the average value of S is equal to that of the average tree or the average of the test trees. Knowing the average value S , the volume below breast-height of the stand is found from the formula $V = B \times S$, in which V is the total volume below breast-height.

If no studies of absolute form factors have been made and hence no tables of average values are available, the method is applied in the following way: The trees on a given plot are calipered in the ordinary manner, then test trees are selected by one of the methods described in the preceding sections. For simplicity, suppose that the mean sample-tree method is used. After obtaining the diameter of the average tree, 3 to 5 test trees are selected, felled, and measured for volume. By averaging together the measurements of the test trees, one obtains an average value of the height above breast-height (H), the absolute form factor (F), and the distance between the stump and breast-height (S). The total volume of the stand then is obtained from the formula

$$V = (B \times F \times H) + (B \times S),$$

in which B is the total basal area of the stand.

If branch wood is to be included in the computation it is reckoned as a certain percentage of the total volume. This percentage is obtained from the study of the test trees.

The method as described above has no special advantages over several other methods. Its chief value lies in its application to estimating. Numerous tests of the method in Europe in second-growth hardwoods have shown that the average absolute form factor usually lies between 0.4 and 0.5, and in a normal stand is about 0.45. If after a practical study of absolute form factors in a specified forest region the average of a given species lies within certain definite limits, as 0.4 and 0.5, and is most often a certain number, say 0.45, one can soon train his eye so that he can tell by an inspection of standing timber approximately what the absolute form factor will average.

As soon as a forester becomes sufficiently expert to estimate the absolute form factor, the cutting of test trees may be dispensed with. The trees are calipered to obtain the total basal area B , then the average height above breast-height H and the average value of S are estimated, and the total contents of the stand computed by the formula given above.

This method is specially applicable to the measurement of cord-wood. It has already been used in this country in a few instances.

CHAPTER XV.

DETERMINATION OF THE AGE OF TREES AND STANDS.

137. The Age of Felled Trees.—A tree increases in diameter by the formation of a new layer of wood each year between the old wood and the bark. These annual layers of wood make the concentric rings seen on stumps and ends of logs. The number of rings on the cross-section of a tree indicates the age of the tree at that point. To find the correct age of a tree the rings must be counted at the ground. The number of rings at a cross-cut, made at some distance above the ground, as, for instance, at the top of a sawlog, would show only the number of years required by the tree to grow above that point, for the reason that the tree cannot begin to form rings at any point until it has grown up to it. Therefore the number of rings on the stump of a tree usually does not represent its correct age, because most forest trees require several years to grow up to the stump-height. In many cases it is difficult to determine with certainty the correct age by counting the rings at the ground because the growth of the seedling is small and the first few annual rings are very difficult to distinguish on an old tree.

The increased accuracy resulting from cutting trees at the ground does not pay for the expense and trouble involved. For many purposes the age at the stump is considered close enough, but in most scientific studies a greater degree of accuracy is required. In such work the rings are counted on the stump, and to this figure is added the average number of years required

by the species in question to grow to the height of the stump. This extra number of years is estimated or is obtained from a study of small seedlings. To ascertain the average height growth of small seedlings, a large number are cut at the ground and their rings are counted; and from these figures a table is constructed showing the average age of seedlings of different heights, like the following:

Height of Seedling, Inches.	Age, Years.
3	1
6	2
12	3
18	4
24	5

Suppose, for example, that a tree with a two-foot stump is cut, its age would be found by adding five years to the age shown by the rings at the stump, since the above table shows that five years is the average period required for a tree of the species to grow two feet above the ground.

It is often difficult to count accurately the annual rings on a stump or other cross-cut. In some species, as, for example, the maples and beech, the rings are not distinct from each other. Again, when the growth has been slow, the rings are very narrow and difficult to distinguish and count. Sometimes when the growth is interrupted early in the year, on account of a drought or for some other cause, and later on during the same season new leaves are put forth, a second or false ring is formed. As a rule, however, the dividing marks between two growths of a single season are not so distinct as between the growths of separate seasons, and the careful observer can detect the so-called false rings.

When the rings are not easily distinguished from each other a perfectly smooth surface should be made with a knife or axe; a chisel may also be used. If then the rings cannot be readily distinguished and counted, a lens is used. A little fine dirt

rubbed on the cut makes the rings somewhat more distinct. Care should be taken not to count the inside layer of bark, which sometimes has the appearance of a layer of wood.

138. Estimate of the Age of Standing Trees.—The exact age of a standing tree cannot be determined with certainty unless there is a record showing when it was planted. It is often possible to estimate the age of standing trees near enough for the purpose of general forest description, in cases where it is not practical to fell any trees.

One method of estimating the age of a tree is to count the whorls of branches. This can be done only with the conifers and with relatively young trees. Many conifers form each year at the base of the new leader a distinct whorl of branches which marks clearly the annual growth in height for the year. These whorls, or traces of them, may be distinguished in trees growing in the open or in open stands, often to the sixtieth or eightieth year. In forest-grown trees the branch stubs are apt to be overgrown before that time. White pine, spruce, fir, and other conifers having persistent branches show the traces of the annual shoots the longest. Very intolerant trees like the yellow pines and larch soon lose all traces of the branch whorls. If traces of the branch whorls can be found from the ground upwards, the age of a tree may be estimated with a fair degree of accuracy. In estimating age by whorls it is necessary to make a full allowance for the age of the seedling when no branches were formed of sufficient size to show in later years.

Another way to estimate the age of standing trees is by using the Pressler borer. This instrument, shown in Fig. 45, consists of three parts:

(a) A hollow augur, *A*, about four inches long, tapering and threaded at one end, and square in cross-section at the other end.

(b) A hollow metal handle, *B*, with a square opening in the center into which the augur fits when in use. At the ends of this handle are detachable caps.

(c) A narrow wedge, *C*, furnished at one end with a flat head, and incised on one side at the other end.

The wedge and the augur are carried inside the hollow handle when the instrument is not in use.

To use the instrument one bores into a tree to a depth of 2 to 3 inches, then inserts the wedge through the augur with the incised side turned inward. The wedge is jammed down, thus

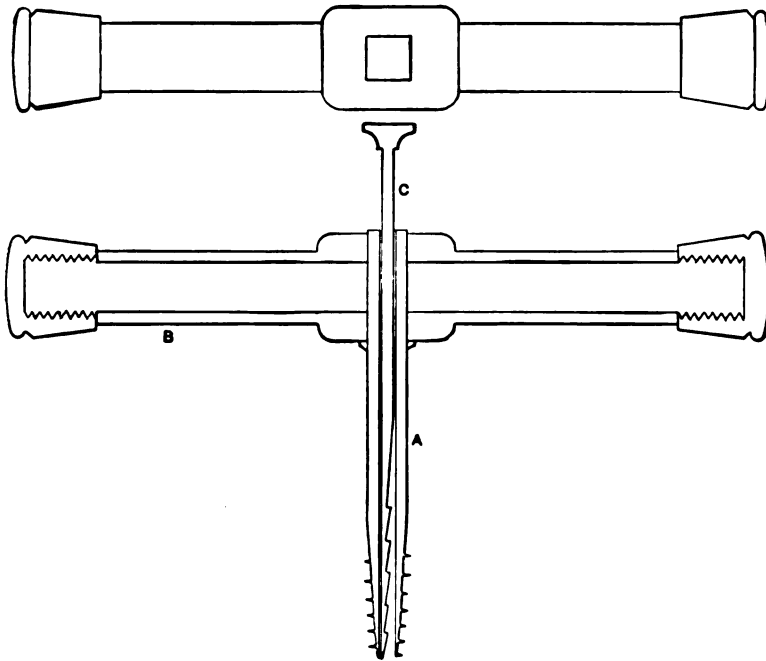

FIG.45.—Pressler's Increment Borer.

holding tightly in place the core of wood within the augur. The handle is then turned sharply to the left, severing the core from the wood. The cylinder of wood is then drawn out, and the rings counted or measured.

To determine the age one bores into a tree to the heart at breast-height, counts on the extracted core the number of rings, and then adds the probable age from the ground to breast-height.

Inasmuch as it is practical to make a boring of only about 3 inches, the method is not applicable to trees over 6 inches in diameter at breast-height. The author has used the instrument satisfactorily in investigations in second-growth forests.

The practiced forester can estimate in general terms the age of a tree simply by inspection. He can estimate trees under 100 years of age within 20 years and above this age to within 50 years. Many external signs indicate age to one who has studied the age of felled trees. The size of the tree under a specified condition of growth, the form of the crown, the shape of the bole, and the texture and color of the bark indicate to the practiced eye the approximate age.

139. The Age of Tropical Trees.—It is impossible to determine the age of trees in those portions of the tropics which do not have a marked annual change of season such as is occasioned by dryness. Trees growing in the Philippines, for example, may show concentric rings, but these do not mark annual growth; and usually it is impossible to distinguish the rings clearly. The forester is obliged to use studies of growth which already have been made and estimates the age from the probable mean annual growth of the tree. If the investigations show that the average mean annual growth of a specified species is one inch in four years, the age of a tree 40 inches in diameter is called 160 years. As shown later, the growth of tropical trees which do not show annual rings must be studied by taking periodically measurements of the diameter of selected standing trees.

140. Determination of the Age of Stands.—By the age of a stand is meant its average age. The average age of a stand has no practical value if there is a very wide difference between the age of the youngest and the oldest trees. In an all-aged stand (selection forest) it is customary to describe the range of ages and the representation of the different ages. Thus a northern virgin hardwood forest might be described as having an age range from young seedlings to 150-year-old veterans, with 70% over 100 and the remainder under 50 years old, the intermediate

ages lacking. If there is considerable variation in age in a given stand, but it is not all-aged, the age range and the general average age are estimated. The age of such a stand is expressed by a fraction, in which the range of age is in the numerator and the average age in the denominator. Thus, for example, $\frac{60-100}{70}$ years means that there is a range of 60-100 years in age and the average age is about 70 years. If a stand is exactly even-aged or nearly so, the average age is often determined with care, as, for example, in making yield tables.

Strictly speaking, an even-aged stand is one which has been established in a specified year. The term is, however, not used very strictly and a stand which does not show wide differences in age in the main crop is called even-aged. The age of such a stand is the average age of the principal crop. If an occasional old specimen of advance growth occurs, it is disregarded in considering the age. Again, if small specimens of a tolerant species occur under the main crop, they are disregarded or considered by themselves.

It is nearly always possible to determine by inspection whether a stand is exactly even-aged or not. If it is obviously even-aged, like a plantation, the age is found by cutting down one tree of average size. It is much better to cut a tree of average size than a small one, because on small trees the rings are apt to be very close together, leading to mistakes. Frequently on suppressed trees which are dying the growth of the last few years is not represented at all at the base. It is best not to judge the age of a stand from a large tree because it may have been advance growth and hence would be a few years older than the prevailing crop. Ordinarily it is best to determine the age of several average trees, rather than only one, even when the stand appears very even-aged. It often happens that exact records exist when a given stand was established. Of course it is then unnecessary to fell any trees for an age study.

Nearly all so-called even-aged forests in this country are

only approximately even-aged because they have originated from natural reproduction. The period of reproduction on an opening is usually 10 to 30 years, or even more, resulting in rather uneven-aged stands. A stand having a range in age of even 20 or 30 years forms a fairly even crown canopy when it reaches middle age—that is, 40 to 60 years—and is classed as an approximately even-aged stand. Such stands are used in constructing normal and empirical yield tables and their average age exactly determined.

The German conception of the average age of stands which are not strictly even-aged is that age which would be necessary to produce an even-aged stand of the same volume as that of the uneven-aged stand in question. There are several ways of obtaining the average age of approximately, but not exactly, even-aged stands. Ordinarily when an average age is desired it is in connection with a sample plot where test trees are cut for volume computation. If the mean sample-tree method is used, the average of the ages of the test trees is considered the average age of the stand. This method is sufficiently accurate for any investigation which permits the use of the mean sample-tree method for the computation of volume. When a method of diameter groups with the felling of test trees is used, the simplest though not the most accurate method of ascertaining the average age is to take the average age of all test trees.

The only objection to this plan is that in a method like the **arbitrary group method** diameter groups having a small volume are given relatively as much weight in the average of age as those with a larger volume and therefore the condition of the definition of average age given above is not carried out. To overcome this difficulty the following formula has been suggested:

$$\text{Age} = \frac{n \times a + n_1 \times a_1 + n_2 \times a_2 + \dots}{N},$$

in which n, n_1, n_2 , etc., are the number of trees, a, a_1, a_2 , etc., the average age of the test trees in the diameter groups, and N is

the total number of trees. But even by this plan an average age is not obtained which satisfies the requirements of the definition on page 250. This represents an arithmetic rather than a geometric average age. If there were in a stand a very large number of small trees which do not contribute largely to the volume and which are correspondingly younger than the larger diameter classes, the average age calculated by the above method would show the stand to have reached the present volume in too short a time.

The most exact results would be obtained by a geometric formula based on volume. The volume method (so-called Smalian method) is based on the principle that the true average age of a stand is found by dividing the total volume by the mean annual growth,

$$A = \frac{V}{M},$$

in which A is the average age required, V the total volume, and M the mean annual growth. If a stand has been calipered and the trees divided into diameter classes, test trees felled, and so on, the mean annual growth of each diameter group is the volume of the group divided by the average age (the average of the ages of the test trees). The age of the stand may be obtained by the formula

$$A = \frac{v + v_1 + v_2 + v_3 + \dots}{\frac{v}{a} + \frac{v_1}{a_1} + \frac{v_2}{a_2} + \frac{v_3}{a_3} + \dots},$$

in which v, v_1, v_2, v_3 , etc., are the volumes and a, a_1, a_2, a_3 , etc., are the ages of the diameter groups.

Theoretically this formula gives the most accurate results of all the methods. The objection usually made to it is that it is clumsy and time-consuming. This is not a proper objection because it is designed only for very accurate investigations such as the preparation of yield tables.

Another geometric method is by the basal-area formula

$$A = \frac{ba + b_1a_1 + b_2a_2 + \dots}{B},$$

in which A is the age, b, b_1, b_2 are the basal areas of the diameter groups, a, a_1, a_2 the ages of the diameter groups, and B the total basal area of the stand. This method is theoretically correct if the form heights of the diameter groups are equal. The method has no particular advantage over the previous, because neither would be used except where sample plots are taken and the volume of the separate diameter groups is to be calculated.

141. Economic Age.—This conception of age was used by T. Lorey with the silver fir, because silver fir usually starts under very unfavorable circumstances and is often suppressed for many years.* At the center of the stem there is, then, usually a small cylinder of very hard wood where the growth is extremely small. The total age of a tree does not at all represent its possibility for growth, because a number of years were passed in deep shade. As soon as released, the tree shoots ahead and makes a rapid growth. The economic age of such a tree is not represented by the total number of years from the seed, but by the number of years after its release from suppression plus the average period of suppression in the forest under examination. To ascertain the number of years to be added, a separate study is made, involving the analysis of a large number of trees and the determination of the period of suppression of each. Then a table of the following form is constructed showing the average number of rings in central cores of suppression of different diameters:

Diameter of Core.	Average Age.
.....
.....
.....

* Ertragstafeln für die Weisstanne, by T. Lorey, Tübingen, 1884.

To obtain the economic age of a given tree, the rings are counted outside its central core of suppression, the diameter of the core is measured, and from the table the number of years corresponding to this diameter is taken and added to the age after suppression.

Suppose, for example, that the diameter of the core of suppression of a given tree is 2 centimeters, the number of rings outside the core 70, and the number of rings inside the core 25; and that the table shows for a core 2 centimeters in diameter an average age of 14 years. The economic age of the tree is, then, $70 + 14$ or 84 years, and not $70 + 25$ or 95 years.

CHAPTER XVI.

THE GROWTH OF TREES AND STANDS.

142. Different Kinds of Growth.—In forest mensuration it is customary to distinguish between the growth of trees in *diameter*, *sectional area*, *height*, and *volume*. The increase in volume of a tree or stand is technically called *increment*; the increase in diameter, sectional area, and height is called *accretion*. Some authors use the expressions diameter increment, height increment, volume increment, etc. In practice, however, foresters use the term *growth* instead of increment or accretion, as diameter growth, height growth, etc.

Diameter growth is determined for single trees. Growth in volume and sectional area is studied for stands as well as for single trees. Studies of height growth are made for single trees, and for stands provided they are even-aged or nearly so.

Quality growth or increment is the increase in value per unit of volume as applied to a single tree or stand.

Price growth or increment is that resulting from an increase in the price of forest products independent of quality growth or increment.

Forest mensuration is not concerned with the growth of trees and stands in weight, by which is meant the increase in ponderable substance measured in pounds or other unit of weight. This subject belongs rather to forest technology.

The growth of a tree or stand may further be distinguished as: *Current Annual Growth*, or the growth of a specific year.

Periodic Growth, or the growth during a specified period of years.

Mean Annual Growth, which is obtained by dividing the total growth during the life of the tree by its age.

Periodic Annual Growth, which is obtained by dividing the growth during a specified period by the number of years in that period.

Some German authors use the term *total growth*, referring to the total product of growth from the seed or stump. This is, however, really the same as periodic growth, except that periodic growth is generally taken only for a decade or two and not for the whole life of the tree.

In the United States many tables of growth are made which show the number of years required for a tree of a specified size or age to grow 1 inch in diameter. This is the same as periodic growth. Another common method of expressing growth is to show the average age of trees of different sizes, which is a way of expressing total final growth.

Growth may be calculated for a certain year or period in the past life of a tree, or may be prophesied for a future year or period. For example, the growth in diameter for the past few years may be measured with the Pressler increment borer. This is called reckoning backward. The same figures may be used to estimate the growth during a future period. This is called reckoning forward.

In many computations the relative rate of growth is required; that is, the ratio between the present condition of a tree or stand and the growth occurring in the succeeding year. This is expressed as growth percent and is calculated by the ordinary simple-interest formula. Suppose, for example, the growth in diameter to be in question. Let D = the diameter now, a = the growth expected next year, and P = the growth percent, then

$$P = \frac{a \times 100}{D}.$$

In most work *periodic annual growth* is used instead of *current annual growth*. The reason for this is that it is difficult and laborious to measure separately the growth of single years in the life of a tree. It is comparatively easy to measure the growth of a period of years; for example, a decade. In addition, more satisfactory results are usually given by the *periodic annual growth*, because the annual variations of growth due to unusual conditions, such as cold season, drought, defoliation by insects, etc., are more or less eliminated by the averaging.

In general the current rate of growth of trees, as well as of stands, is small in early youth; later on, at a period differing with different species and under different conditions of site, the rate of growth increases, and then in late life it decreases as the life energy of the trees falls off. This is true of the rate of growth in diameter, height, and volume. When the current annual growth of a tree or stand is compared to its mean annual growth, it will be seen that the latter is at first the smaller, it increases more slowly, and begins to fall off at a later period. The mean annual growth reaches its maximum at the point when it is equal to the current annual growth. This relation between the two kinds of growth must be considered, for the forester frequently has occasion to determine both the mean annual and current annual growth of a tree or stand, or to choose which kind of growth should be used in a given problem.

143. Tree Analyses.—The measurement of a felled tree to determine its growth is called a *tree analysis*. Tree analyses vary with their purpose, and may include all measurements required to compute the growth in diameter, area, height, and volume, or only a part of them. A complete tree analysis comprises the following measurements: Length of each section, diameter inside and outside the bark at each cross-cut, the total age, the age and width of the sapwood, the diameter growth at each cross-cut, the diameter breast-high, the total height, the clear, used, and merchantable lengths; and a full description of the trees is also made.

If the diameter growth is measured only at the stump, a *stump analysis* is made. A *section analysis* includes measurements of diameter growth at more than one section. A *partial stump* or *section analysis* is one in which measurements of diameter growth include only a part of the rings, as when one measures the growth for the last ten years.

Only sound trees should be selected for tree analysis. It is not possible to measure the annual growth accurately on a cross-section which is unsound. Rotten spots may prevent the correct determination of the age, and even if the rings can still be distinguished, often cause inaccuracies on account of the shrinkage of the unsound rings. Wounds which have been healed over cause a distortion of the rings and prevent a fair measurement of the annual growth. The trees should be as nearly straight and round as possible, unless irregularity of shape is characteristic of the species or group of trees under investigation. Each tree should be representative of its class. In all cases one should avoid the selection of trees with abnormal crowns, because an abnormal crown means abnormal growth. The size of the trees selected for measurement depends on the specific problems under investigation.

144. Preparation of a Felled Tree for Measurement.—Where merchantable trees are analyzed, they are cut into regular merchantable log lengths, as described on page 111, and the age and measurements of diameter growth taken at the stump and at the tops of the logs. If there is a long piece above the last cut, it is usually cut into 10-foot lengths and the rings counted and measured at the new cross-sections. When second growth is studied and the trees are cut primarily for tree analysis, greater care may be taken to cut the stumps at an equal height or to make their heights proportional to the diameter. The German custom is to make the stump-height one-third of the diameter measured at the point where the principal root swelling begins. When possible the logs are made a uniform length, usually determined by the local market conditions. For example, if the average log-

length for the species in question is 12 feet, that length is chosen for the analysis work. If, on the other hand, ties are the principal product, 8 feet would be chosen. If pulp is to be manufactured and 4-foot bolts used, a multiple of four would be taken as the log-length. In some studies of growth it is desirable to use a uniform length of log, but this is not always necessary, as will appear in the discussion of special problems. The cross-cuts should be made, when possible, with a saw in order to obtain an even surface for the measurement of the rings. The cross-cut should always be brought to a right angle to the axis of the tree, since diameter measurements taken on a slanting cross-cut would give too large results.

145. Determination of the Average Radius.—After a cross-section has been made perfectly smooth, so that the rings can be counted, the average radius from the bark to the pith is determined. If all cross-sections were perfect circles and the pith were exactly in the center, the measurement of rings could be taken at any point. But this is seldom the case. Therefore, in order to obtain a true measurement of the diameter growth, the rings are measured along an average radius. An average radius of a section is equal to the radius of a perfect circle whose area is the same as the area of the cross-section. Theoretically the average radius should cut each ring perpendicular to a tangent at that point, which would be the case if the cross-section were a perfect circle and all the concentric rings were perfect circles. This is often not the case, and even when the cross-section is a circle, some rings are irregular and the average radius intersects them slightly at an angle. This method gives, however, the average width of the rings very closely, and is the only practical way to obtain the ring measurements, which, all taken together, exactly equal the average radius.

The average radius is one-half the average diameter. The usual rule given for obtaining the average diameter is to average together the longest and the shortest diameters, taking these, where possible, at right angles to each other. In this case one

measures first the longest diameter and takes the other at right angles to it. This method works very well where cross-sections are oblong or elliptical, but with lop-sided cross-sections or those flattened on four sides the best results are obtained by measuring the longest and shortest diameters, even if they are not at right angles to each other. Another method is to measure first what appears to be an average diameter and then take the second diameter at right angles to it. The best rule for studying growth is to measure only trees which are fairly regular in form and then to use the first rule, namely, to average together the longest diameter and that taken at right angles to it.

Sometimes it is a characteristic of a species to have irregular stems. For example, red cedar often has a very irregular trunk and the periphery in cross-section is wavy or even scalloped. In this case one measures several diameters which appear to be average and takes their mean.

The average diameter of a cross-section should be taken inside the bark. Erroneous results are often obtained by measuring with calipers the diameter outside the bark and then deducting the width of the bark. This is particularly true at the stump, where the bark's thickness is very uneven or so much bruised that an accurate measurement of diameter cannot be obtained.

If a cross-section is irregular in shape, care must be taken that the shortest diameter is a true diameter, passing through the true center (not necessarily the pith) of the cross-section. This can be judged by the eye or the measurement may be made with the calipers (inside the bark), which guarantees that the diameter lies between two parallel lines tangent to the circumference of the cross-section.

A more accurate radius is obtained by determining first the average diameter than by averaging together directly the longest and shortest radii. With the steel calipers a very quick method is to place the point of the stationary arm on the pith, swing the instrument around to the nearest, and then the farthest, point of periphery, average the measurements, and then by setting the instrument at this average figure find the average radius. The result

on an eccentric cross-section might, however, be inaccurate, as is clear from the following extreme illustration:

Suppose that a cross-section has the form of an ellipse, and the pith is located on the axis of the ellipse, half-way between the center and one end. The average radius, determined with the increment calipers, would be equal to one-half of the major axis of the ellipse. It is obvious that the area of the corresponding circle would be greater than that of the ellipse.

When the average diameter has been determined, it is divided by 2 for the average radius. A place on the cross-section is then found which measures, from the pith to the bark, exactly the average radius, and a line is ruled off with a pencil at this place. Then the rings are counted and measured along this average radius.

146. Instruments for Measuring Diameter Growth.—It is customary in this country to measure the width of the annual rings in inches and tenths. Usually a simple flat scale rule 6 or 12 inches in length is used. A good rule is made of boxwood, with edges covered with a hard white composition resembling ivory, which strengthens it and makes the graduations easy to read. Steel scale rules are often used.

A capital instrument for measuring diameter growth is the steel calipers shown in Fig. 46. This consists of a beam of steel

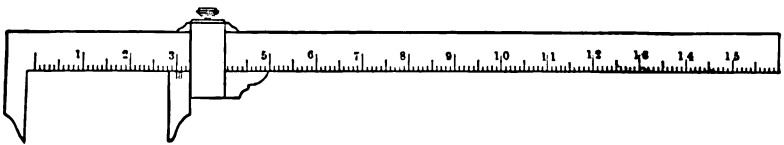

FIG. 46.—Steel Increment Calipers.

or other metal having the usual graduations and furnished with two arms, one of which is fixed, the other movable. The fixed arm is at one end of the beam; the movable arm depends from a sliding head furnished with a set-screw. The ends of these arms are not square, but are cut away at the corners so as to bring the ends to a sharp point, the outer corner of the fixed

arm and the inner corner of the movable arm being thus cut away. In measuring growth-rings, the point of the fixed arm is placed upon one edge of the ring and the movable point brought to bear upon the opposite edge. In this way the rings can be measured, not only with all the accuracy of caliper work, but with great rapidity.

Sometimes narrow strips of stout paper are laid on the cross-section and the widths of the rings marked on them. They are afterwards measured in the office by a scale rule or by the increment calipers already described.

A number of attempts have been made to secure prints of the annual rings of cross-sections by means of carbon paper, which may be studied afterwards in the office. On trees which have a very porous grain it is possible to obtain a print of a cross-section by placing a piece of carbon paper between the wood and a sheet of ordinary paper, and rolling the surface with a rubber roller. Better results are obtained if the surface of the wood is washed with a chemical preparation which eats the soft portion of the annual rings, but does not affect the dense wood. The method is impractical, because it is not possible in the woods to make a cross-section of a tree smooth enough to secure a perfect print which will include all the rings. The method is, however, admirable to secure prints of sections of wood desired for special illustration, as for a publication, when time can be taken to prepare perfect specimens in the office.

147. Counting the Annual Rings from the Pith Outward.—

Whether the rings should be counted from the bark inward or from the pith outward depends upon the character of the investigation. When the forester wishes to determine merely the average rate of growth in diameter, but does not intend to study the growth in volume, the simplest method is to begin at the pith and count outward, marking each tenth ring. He then lays his ruler along the pencil line and first measures the distance from the pith to the first ten-year mark, then from

the pith to the second ten-year mark, then from the pith to the third ten-year mark, and so on; and finally from the pith to the bark. The last measurement must correspond to the average radius. If each of these measurements is multiplied by 2, the results are the diameters at 10, 20, 30 years of age, and so on.

148. Counting the Rings from Bark toward Pith.—In most investigations the rings on a cross-section are not counted from the pith outward, as just described, but, beginning at the bark, are counted inward. The reason for this is that the forester generally uses the measurements for volume growth, as well as for diameter growth, and wishes to determine the dimensions (and from these the volume) of the tree as it now is, as it was 10 years ago, 20 years ago, 30 years ago, etc. The dimensions 10 years ago may best be determined by deducting from the diameters at different cross-sections the diameter growth at those sections for the last 10 years. Accordingly the rings at the different sections are counted along the average radius beginning with the bark and proceeding toward the center, each tenth ring being marked to facilitate the measurement by decades.

Fig. 47 shows the theoretical cross-section of a log 49 years old. The rings are counted on a chosen radius, beginning with the periphery and working inward, and each tenth ring is marked. Between the pith and the inside mark there are nine rings.

When the rings have been counted, the following measurements are taken on the average radius:

First, distance from pith to inside decade mark, 1 in Fig. 47.

Second, distance from pith to second mark, 2.

Third, distance from pith to third mark, 3.

Fourth, distance from pith to fourth mark, 4, and finally, distance from pith to periphery, which is the average radius.

These figures of growth are usually entered in a special form. The form used by the U. S. Forest Service is shown on page 264. It

will be noticed that there is space for the measurement of diameter growth at 10 cross-sections and that the form may be used for trees up to 300 years of age.

Usually an accurate tree description accompanies each tree

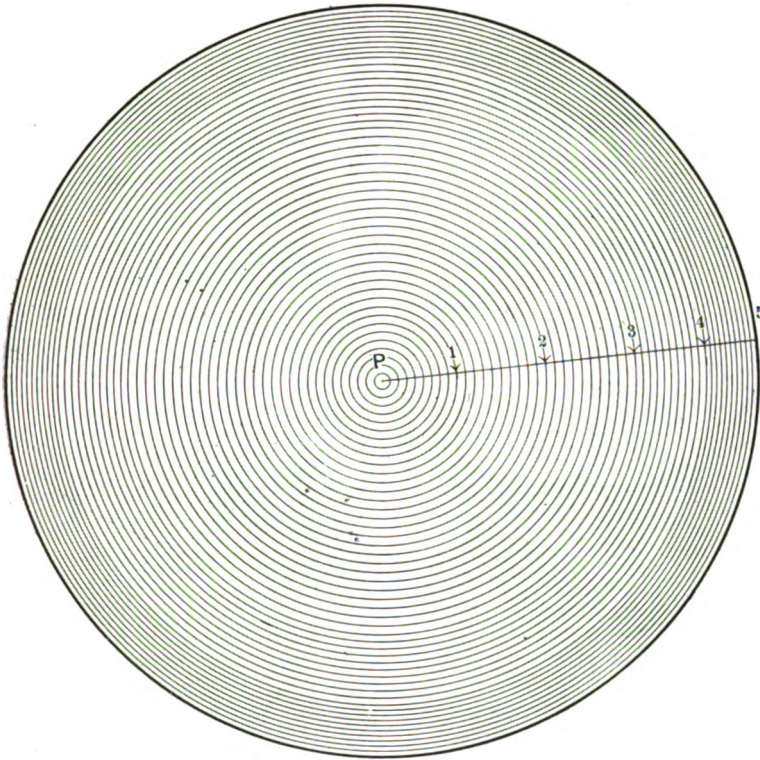

FIG. 47.

analysis. This tree description should include the tree class, the form of crown (preferably by a sketch), the length and width of crown, the clear length, merchantable length, health, and form of bole. It is customary also to make a forest description, especially where the trees occur in different types of forest and

in sites of different quality. These descriptions assist in the classification and grouping of the different tree analyses and explain any peculiarities of growth. A full description of the site and the stand should include the situation, absolute and relative altitude, slope and aspect, rock, soil, humus, litter, brush and herbaceous growth, reproduction, forest type, form of stand, size and age of trees, trees in mixture, density, quality of site, silvical condition, merchantable condition and estimated yield per acre. In some studies of the growth of individual trees, however, a full forest description is unnecessary; or if one were measuring a large number of trees in one place, it would be necessary to make only one forest description to cover all of the trees in the stand.

149. Investigations of Diameter Growth.—The purposes of the study of diameter growth may be:

1. To determine at what age a given species under given conditions will become merchantable.
2. To compare the rates of growth of two species, or of the same species under different conditions.
3. To illustrate the results of certain kinds of treatment.
4. To serve as a step in the determination of volume growth.

It is seldom that the specific objects of an investigation can be accomplished by the measurement of trees selected in a haphazard fashion. Thus some foresters make a practice of measuring the growth on stumps whenever an occasion is offered. A miscellaneous lot of such measurements would have little value for statistical purposes, though they assist the forester himself to a better knowledge of the life of the tree and are of value in estimating growth in the absence of more elaborate data. General growth studies, which aim to give the average results of trees growing under a number of different conditions, are not valuable for practical work. Therefore the data for diameter growth should be collected according to a definite plan, and with the proposed uses of the results of the investigation constantly in mind.

Almost every question of diameter growth can be better answered by a study of volume growth. But investigations of volume growth are very slow and expensive compared to those of diameter growth; so that when possible the latter have been used in this country.

150. Determination of Diameter Growth.—By growth of a tree in diameter or sectional area is meant the growth at breast-height or at the stump. The most useful tables of diameter growth show the rate of growth at breast-height outside the bark. These tables are the most useful because standing trees are measured and classified by the diameters at breast-height. As a rule, however, measurements of growth cannot be taken at breast-height because such a high cut wastes valuable timber. Therefore the diameter growth inside the bark on the stump is first determined, and the diameters outside the bark at different ages are estimated by a study of the average ratio between the stump diameter inside the bark and that at breast-height outside the bark, obtained from a large number of trees of different sizes. The average rate of growth in diameter of a number of trees is obtained by means of a diameter curve. The diameter measurements of each tree are first plotted on cross-section paper, on whose horizontal lines are laid off the ages and on the vertical lines, the diameters. Suppose that there are 53 rings and that they have been counted from the bark inward. One enters first the growth of the innermost three years; that is, twice the distance from the pith to the inside decade mark; then the diameter growth for 13 years, then for 23, 33, 43, and 53 years, the last being the average diameter of the tree. An average curve is drawn through the points and from this curve a table is constructed showing the average diameter of the trees at 10, 20, 30, 40, and 50 years of age.

The results from the curve show the average diameter of the trees at different ages *inside the bark* at the stump. But when one wishes to know the diameter of a tree at a specified age, it is the diameter at breast-height outside the bark, and not that at

the stump inside the bark. To be sure, tables of growth at the stump for different species show comparative rates of growth very well. It should be borne in mind, however, that the rate of growth at the stump is greater and is less uniform than at breast-height.

The breast-height diameters of the trees at different ages are determined in the following way: The difference, in inches, between the diameter of each tree at breast-height, outside bark, and its stump diameter, inside bark, is calculated; then the trees are grouped by diameters inside the bark at the stump; and for each inch class the average difference between stump and breast-height diameters is computed and arranged in a table like the following:

Diam. inside bark at stump, inches.	5	6	7	8	etc.
Difference between diam. inside bark at stump and outside bark at breast-height, inches.	0.1	0.2	0.3	0.4	etc.

These figures may then be applied to the stump diameter curve as reducing factors to construct a breast-height diameter curve. Thus one finds where the 5-inch ordinate intersects the stump curve and makes a mark on this ordinate 0.1 inch below the curve; then makes a mark on the 6-inch ordinate 0.2 inch below the curve, and so on. . These new points are joined by a curve which represents the growth at breast-height as nearly as it is possible to determine it without actually measuring the rings of the trees at that point.*

* Some may object to this method on the ground that the average difference between the stump and breast-height diameters is determined for trees of different sizes without regard to age. It would, of course, be possible to first ascertain from the stump curve the average age of the 5-inch trees and then use only 5-inch trees of that age to determine the difference between the stump and breast-height diameters; and in the same way use trees of specified ages to determine the reducing factor for the other diameters. The author does not know of any investigation having been carried out in this way

If the rings are counted and measured at breast-height, a diameter growth curve is made, just as was described for the growth on the stump. This curve shows the rate of growth inside the bark at breast-height, and to be really useful must be corrected to show the diameters at different ages outside the bark. To accomplish this, it is necessary to measure the width of the bark, at breast-height, of trees of different sizes and ages. Thus one would determine from the diameter curve the age of 6-inch trees and then measure on a number of trees of approximately that size and age the thickness of bark at breast-height, and do the same for the other sizes. The average bark thicknesses may then be applied to correct the first curve, and a new curve may be drawn showing the diameter growth at breast-height outside the bark.

151. Separate Studies Made for Trees Growing under Different Conditions.—The rate of diameter growth of trees varies so greatly that a study of average growth under a great variety of conditions has little practical value. Almost every practical question of growth has to do with a particular set of conditions, for which a separate table of growth must be made. In the first place it is necessary to distinguish between trees grown in even-aged and uneven-aged stands. Usually separate growth tables also have to be made for different forest types and for different soil classes, and sometimes separate tables of diameter growth should be made for stands of different density, as, for example, for dense, interrupted, and open stands.

The most important problems are discussed in the succeeding pages.

152. The Study of Diameter Growth in Even-aged Stands.—One of our important problems is to determine the rate of growth in diameter of trees growing in even-aged stands. Even-aged, or approximately even-aged, stands are very common in many sections, occurring usually where the land has been cleared by cutting, windfall, or fire. Conspicuous examples of even-aged stands are: The bulk of sprout stands; birch, poplar, and other

second growth on extensive burns in northern New England; spruce in old pastures, on burns, and on areas cleared by wind-fall; white pine on burns and abandoned land; second-growth white cedar (*chamæcyparis*) near the coast; pitch, short-leaf, loblolly, Virginia pine, and practically all other pines in the Central and Southern States, coming up as second growth on abandoned fields and burned land; white, jack, and red pine in the Lake States on old clearings and burns; lodge pole pine, yellow pine, red fir, and many other conifers, which follow fires or occupy clearings in the far West. In other words, an important part of the second growth of the whole country is in the form of practically even-aged stands. Inasmuch as all plantations and all clean-cutting systems of natural reproduction furnish even-aged stands, the study of growth of trees in this character of forest requires special consideration.

Generally the average diameter growth of even-aged stands is sought to answer such questions as: What are the mean and current rates of diameter growth at different ages? How long does it take on an average to produce a merchantable crop? How soon will a specified young stand become merchantable? Such a study must, however, presuppose a certain method of management, particularly in the matter of making improvement thinnings. If the purpose is to show the rate of growth of even-aged stands in which improvement thinnings are not made, then one takes the measurements of growth in volunteer stands, which represent, as nearly as one can judge, the conditions which will obtain where the figures of growth are to be applied. Suppose, for example, that an investigation is made of diameter growth in second-growth sprout stands. Usually separate tables of growth are made for different forest types. One would select the trees for analysis in a given forest type in stands which represent the average prevailing conditions in that type. The resulting tables of growth may be applied to similar land where presumably the trees will grow as on the area studied. After locating repre-

sentative stands, the trees are selected for tree analysis, with due regard to their form and health, as explained on page 257, and also with regard to proper size.

Several methods of determining the size of the trees to be analyzed are distinguished:

(a) *By the Analysis of all Trees on Selected Plots.*—By this plan selected sample plots are laid off and all the trees on them analyzed and the measurements of their growth averaged together. Generally only such trees are included as will probably reach merchantable size; the owner is not so much interested in the trees which die through suppression. The best way is to use for the study stands which already are of merchantable size, and not to include for analysis any suppressed trees. This method is practicable in forests where timber is being clear-cut, as in sprout forests. It is a simple matter to follow the choppers and analyze the trees before they are removed. Several plots judiciously located in each forest type would yield enough material for most practical purposes.

If stands are used which have not reached merchantable size, only such trees should be analyzed as later will probably become merchantable.

(b) *By the Analysis of Average Trees.*—In this method one lays off sample plots, as in the preceding method, then calipers the standing trees on each plot and determines the diameter of the average tree. A number of trees of average diameter on each plot are measured for growth. The measurements of all trees analyzed in a single forest type are then averaged together. This method gives fairly good results when average trees from merchantable stands alone are used. The resulting tables show the average rate of growth of the trees which reach maturity, without regard to the growth of the trees which die before the stand is mature. In this connection it must be borne in mind that an average tree in a mature stand has not always been the average tree. A tree which at 60 years of age has an average diameter will not necessarily have an average diameter

when the stand is 80 years of age. In any even-aged stand changes are constantly taking place, one of the most important being the reduction in the total number of trees and in the number constituting the dominant crop. If a stand is measured at 30 years and again 20 years later, it will be found that a large number of trees have died and that the tree which represented the average at 30 years is below the average at 50 years, because some of the trees which were used in determining the average diameter at 30 years have died within the period. The trees which died were naturally among the smallest and their absence proportionately increases the average diameter when the stand is 50 years of age. The growth of average trees in a merchantable stand represents fairly well the average growth of the trees which are standing at the present time.

(c) *By the Average Diameters of Standing Trees.*—One of the objects in the study of diameter growth is to determine for different ages the diameter of the average tree whose volume, multiplied by the total number of trees in the stand, will give the volume of the stand. When this object is to be attained the method just described is not strictly applicable, because it gives for different ages only the average diameter of the trees which reach maturity, not the average diameter of all the trees in the stand. The simplest method is to compare the diameters of average trees in stands of different ages without making any tree analyses at all. In this method sample plots are taken in even-aged stands of different ages, as, for example, stands about 20 years old, 30 years old, 40 years old, and so on, up to maturity. The diameter of the average tree and the average age of each stand are obtained. These figures are then compared and averaged by a diameter curve based on age in the following manner: On a sheet of cross-section paper, whose horizontal lines represent years and whose vertical lines represent diameters, are plotted the average diameters for stands of different ages. An average curve is then drawn through the different points.

From this curve is obtained a table giving the diameter of the average tree of stands at different even decades.

The advantage of this method is that it gives results directly in terms of the breast-height diameter, and thus answers one of the practical questions of the study of diameter growth. Measuring one hundred plots in each forest type gives excellent results.

(d) *By Averaging Together Selected Trees of Different Sizes.*—A common method of selecting trees in even-aged stands is to follow the choppers, taking the trees just as they come. No plots are taken and there is no rule regarding the size of the trees measured, except that the forester sees to it that the different sizes are well represented. If enough trees are used, a very good average result is obtained. A thorough investigation would ordinarily include at least 100 trees in each forest type.

153. The Study of Maximum Diameter Growth in Even-aged Stands.—The methods just described permit the determination of the average rate of growth in diameter in volunteer stands which are not thinned. It is a well-known fact that judicious thinning of a forest increases the rate of growth. The maximum rate of growth compatible with good form of bole and quality of wood is obtained by thinning stands when young and repeating the thinnings at intervals throughout life. It is of importance to determine the rate of growth of stands in which thinnings are begun at the proper time and repeated at proper intervals. Of course this question may best be solved by the use of data collected in stands which have been under management throughout life. But in America very few stands of this character exist. Therefore the growth of systematically thinned stands must be determined by studying individual trees which have had favorable conditions of light and growing space such as are furnished by thinnings. It is fair to assume that by thinnings all of the dominant trees in a given stand can be made to grow as rapidly as the *fastest growing* dominant trees in an

unthinned stand, the qualities of site being equal. Reference is here made to normal maximum trees, and not to occasional stragglers with wide crowns and large rough trunks. The object of forestry is not to produce rough trees, but rather trees with full, vigorous crowns and trunks which will yield satisfactory timber. On the principle, then, that by thinnings one can make the majority of trees grow as fast as the best found in an unthinned stand, the largest trees which have satisfactory stems are selected for analysis. Thus, in a sprout chestnut stand one would usually select for measurement about ten of the largest trees (not including abnormally developed trees). In this way a large number of maximum trees are measured; and their growth measurements, when averaged together, represent the average rate of growth of the trees which reach merchantable size in a systematically thinned forest. The trees which die or are removed by the thinnings are not considered. The determination of the possible number of such trees per acre, which could be produced, under certain methods of treatment, is described in section 194.

If the trees are selected, as described under (a) or (d) of the previous section, the maximum rate of growth may be determined by means of a maximum diameter curve. Suppose that the growth measurements were all plotted on cross-section paper, then a curve is drawn through the highest diameter points. If some points are exceptionally high, and evidently represent abnormal growth, they are excluded. The curve forms an upper boundary of the main body of points and represents the average maximum growth.

154. The Measurement of the Minimum Diameter Growth.—

It is frequently desired to know what the diameter of the smallest trees will be at different ages, and especially at maturity. Suppose, for example, a study of growth shows that the average trees in an even-aged stand of oak sprouts will reach merchantable size at 50 years of age, what will be the size of the smallest trees at that age and how soon will they be merchantable?

The minimum diameter growth may be determined by drawing a minimum curve in the same way as the maximum curve; that is, a curve is constructed through the lowest points represented on the cross-section paper, taking care that no abnormally low values influence its shape and direction. A good way to determine the minimum rate of growth in a thinned forest is to construct a minimum curve for a group of maximum trees selected from an unthinned stand in the manner described in the previous section.

155. Stimulated Growth after Thinning.—It has already been explained, on page 272, how to determine the growth of even-aged stands in which the thinnings are begun at the proper time and repeated at proper intervals. Suppose, however, that the thinnings are not begun at the proper time, but still it is desired to know what the rate of growth will be after the thinnings. Thus, for example, a volunteer even-aged stand of white pine may be thinned for the first time when 30 years old. How will the average rate of growth in diameter after thinning compare with that which would have taken place under ordinary treatment? This question is difficult to answer because it is very difficult to find stands of different ages which have been properly thinned. In the absence of such stands the author recommends the following method to be used until the growth after thinnings can be determined empirically.

While it is often not possible to find a whole stand which has been thinned properly, small patches occur which by accident have been given exactly the right treatment. Thus it is possible to find thrifty trees about which poor individuals have been removed and which have been given the benefit of just the right amount of light for their best development. Such trees are analyzed to determine their rate of growth. The analyses are then grouped on the basis of diameter and age, and the average growth of trees 30 years old and 10 inches, 11 inches, 12 inches, etc., in diameter, is computed. In the same way one

determines the growth of the 40-year-old trees of different diameters, and that of other ages. These figures are then applied to correct the tables of average diameter growth. Thus if the 10-inch trees in the above-mentioned 30-year-old white pine stand were growing at a rate of 2 inches in 10 years, and the study of stimulated increment showed an increase of 50 percent by thinnings, then one may count on 3 inches in the next decade.

It may then be assumed that after a decade the trees will grow at the rate of the 40-year-old trees and a decade later at the rate of 50-year-old trees, etc., presupposing, of course, that thinnings are repeated whenever desirable. In studying increased growth after thinnings it is desirable to select for analysis trees from stands where thinnings have been made at least 5 to 10 years before, for several years are usually required by the tree to adjust itself to the new conditions, and the growth of the first year or two after thinning may not represent the normal increase. It is also desirable to take the measurements at breast-height because the increase of growth at the stump is greater than at breast-height.

156. Rate of Growth in Uneven-aged Stands.—The conditions for growth in uneven-aged stands are much less uniform than in even-aged stands. In many-aged forests the rate of growth of the different individuals of the same species varies so much that usually no attempt is made to average their growth at different ages. Sometimes, however, studies are made of the average mean annual growth of such trees at maturity, as explained in the next section.

Frequently the average rate of growth is determined for special classes of trees growing in uneven-aged stands. Thus one might wish to determine the average diameter growth of the advance trees of a certain species growing upon abandoned fields, as, for example, the chestnut trees which first come in on open fields and develop large crowns and short trunks. Special groups might be made of red cedar growing in the open, red

cedar growing in crowded pure stands, and red cedar starting in the open and later being overtopped; of hemlock growing under pine; tamarack growing over balsam and spruce; white pine among spruce, hemlock, and balsam. A great number of illustrations could be given of special classes of trees which would naturally be grouped together for diameter growth.

Such investigations are made whenever some practical question regarding the growth of a particular class of trees has to be answered. The selection of the trees for tree analysis is not difficult if the purpose of the study and the principle of classification of the trees is understood in advance.

The method of studying diameter growth most commonly used in uneven-aged stands is to compare and average the current rate of growth of trees of different diameters without regard to their ages. This method of study is described on page 278.

157. Determination of the Mean Annual Growth of Trees in Uneven-aged Stands.—It was explained in the preceding section that trees in many-aged stands grow under such variable conditions that a comparison of their growth at different ages has no practical value. It is often desirable to determine how long, on an average, it takes certain species growing in certain forest types to reach maturity or merchantable size. Suppose that, in the work of organizing a certain forest which is managed on the selection system, it has been decided to cut the trees to an average diameter limit of 12 inches. It is of interest to know what rotation this diameter limit represents. Therefore one determines how long it takes, on an average, in the forest under examination, for the given species to reach 12 inches. This is done by measuring a large number of 12-inch trees and counting the annual rings at the base. The average age of the 12-inch trees represents the rotation on which the forest is being managed. In many-aged forests it is customary to use size classes rather than age classes, since the former roughly correspond to the latter. Suppose, for example, that 12 inches is established as a diameter

limit, and for the particular purposes of organization it is desirable to use 3-inch size classes. If the average age of 12-inch trees were 100 years, then each size class roughly corresponds to an age class of 25 years.

It is customary in many investigations in uneven-aged stands to make tables showing the average age of trees of different diameters. Sometimes these tables are used to indicate the current rate of growth in diameter. More satisfactory results, however, are obtained from tables based on the measurement of the growth for the last 10 years, such as are described in the succeeding sections.

158. Prediction of Growth for Short Periods.—There are two methods of determining the probable growth of a tree for the immediate future: first, by measuring its recent growth with an increment borer, and, second, by the use of tables showing the average rate of growth of trees of the same size under similar conditions.

It may be assumed that a tree will grow in the immediate future at the same rate as during the last year, or as the average during the last 5 or 10 years. This assumption is not absolutely correct, because the growth may be decreasing from year to year, in which case the estimate of growth would be too large. In the same way the result would be too small if the annual growth were increasing. As a rule, however, the prediction of growth is made at a period in a tree's life when the rate of growth is not changing rapidly from year to year. For all practical purposes, therefore, the recent growth may be used to predict the future growth for a short period, as, for example, a decade.

The measurements of growth for the last 5 or 10 years are taken with an increment borer, at breast-height. It is, of course, impossible to determine exactly where the average radius is, so that the measurement of growth is not so accurate as if it were taken on a cross-section. For this reason, therefore, one should select trees which are round. If perfectly round trees

cannot be used, two borings should be taken from a single tree. These may be in line with the longest and shortest axes, or at points where the growth is probably about average. Three or four borings from the same tree will, of course, give better results than only one or two borings.

The measurements of the borings should always be taken immediately after their extraction from the tree. One should not hold borings for measurement later in the office, because of the shrinkage by drying. One objection often advanced to the use of the increment borer is that the rings are apt to be somewhat jammed together, particularly with soft wood. With a good instrument skilfully handled this objection is not serious.

A second method of predicting the growth of a tree is by the use of tables of growth of trees of different diameters. These tables and their use are described in the succeeding section.

159. Tables of Growth of Trees of Different Diameters.—Many practical investigations require the current rate of growth of trees of certain diameters, but do not require the age of the trees. Thus, in many of our irregular forests, it is customary to cut the large trees and leave the small ones. If it is known how fast these small trees grow, the owner can tell how soon he can return for a second crop.

To meet these conditions tables are constructed to show the rate of growth of trees of different *sizes*, instead of the rate of growth of trees of different *ages*, as described in the previous sections. Such tables show how fast trees 5, 6, 7, 8, 9, etc., inches in diameter grow, instead of how fast trees 20, 30, 40, etc., years old grow. In our many-aged virgin forests, trees of the same size, even if of different age, have more uniform growth than trees of the same age. Thus, a spruce tree 12 inches in diameter and 100 years old probably grows more nearly like the average of 12-inch trees of the forest than like the average of the 100-year-old trees. It is assumed that 12-inch trees grow at the rate shown for that diameter in the table, until they are 13 inches, when they grow like the average 13-inch trees.

To construct such a table, one first analyzes a large number of trees. As a rule the work is done where lumbering is being carried on, and the trees are analyzed as they are cut by the saw-crews. The measurements required for each tree are the diameter at breast-height and the measurement of the growth at breast-height or on the stump for the last 5 or 10 years. The total age of the tree is not determined unless required for some other purpose. The trees are then grouped together by diameters, and the growth of the trees in each diameter class averaged together. Thus the measurements of growth of the 10-inch trees for the last 5 or 10 years are averaged together; then that of the 11-inch trees, the 12-inch trees, the 13-inch trees, etc., is obtained in the same way and the results arranged in a table. Usually it will be found that the growth increases or decreases more or less regularly from the small to the large diameters. Any irregularities which may occur in this first table are evened off by a curve.

Separate tables are made for different forest types and classes of soil. Usually all trees analyzed in a given forest type are averaged together by diameters regardless of differences in height and crown development. This is not always fair. Thus, for example, it is hardly fair to average together the rate of growth of a 10-inch tree 50 feet high and having a thrifty crown, with one which is 25 feet high and has altogether a different crown development. Under these circumstances a much more accurate investigation of growth is made if the different classes of trees of each diameter are kept separate. Thus spruce growing in a virgin forest may be divided into three tree classes. Class one comprises the tall thrifty trees with full crowns, class three the short trees with inferior crowns, and class two the intermediate trees. This classification may extend to trees of any specified diameter. Other methods of classification may be used, depending on the species and character of the forest. The method of constructing tables of growth is just as described above, except that instead of one figure of growth for each.

diameter there are three; that is, one for each class. A table of growth, made on this principle, can be expressed in the following form:

CURRENT GROWTH IN DIAMETER OF TREES OF DIFFERENT DIAMETERS.

Diameter, Breast-high, Inches.	Annual Growth for Last Ten Years, Inches.		
	Class I.	Class II.	Class III.

The number of trees required for a study of growth of trees of different diameters depends on the uniformity of the forest. Where there are a number of forest types, one usually endeavors to measure at least 1000 trees. Where the growth is measured for the last 10 years and at one cross-section, it should be possible to measure 1000 trees within two weeks, provided that number of trees is available for measurement. In selecting trees for measurement, one naturally must see to it that each diameter is about equally represented.

It will be noticed that in the discussion of this method no mention has been made of stimulated growth after cutting. The assumption has been made that the growth for the immediate future will remain the same as during the past few years. Experience has shown that after lumbering, the trees whose crowns are freed by the removal of the old trees show a decided increase in growth. If, therefore, the lumbering is fairly heavy, figures taken from trees growing in the virgin forests do not give a correct and satisfactory result. If the lumbering is very light—that is, a few trees removed per acre—a large number of the trees remaining may not be at all benefited by the cutting. An average

cut of 15 to 20 trees per acre usually affects the rate of growth of a large number of those remaining, but not of all. The spruce forests of the Adirondacks furnish a good illustration of this principle. When the merchantable trees are cut, there usually remain some large non-merchantable trees, such as unsound or crooked birch, beech, maple, or other species which continue to shade a portion of the small spruce left standing. Only a portion of the young trees, therefore, show a stimulated growth. A study of the growth of trees in unthinned forests would give too small results and measurements of trees showing stimulated growth, too large results. The true average rate of growth may, therefore, be obtained by making two tables of growth: first, a table showing the rate of growth of trees of different diameters in the virgin forests, where no cutting has taken place; and second, a table showing the rate of growth of trees of different diameters, all of which have had their crowns more or less freed by the lumbering. The second table is made up in the following way: The forester finds cut-over land in which old trees have been cut and small ones left standing. Near the stumps of the old trees may be found younger ones whose crowns have been more or less released by the cutting. It is often possible to tell at a glance which have been benefited or likely to have been benefited by the cutting. These are selected for measurement. The measurements are worked up in the same way as described before. By a separate study the average percentage of the trees which will probably be benefited is estimated. Sometimes this is merely estimated by inspection of the forest where the figures are to be applied. A better plan is to survey a few plots and make a record of the trees which by their proximity to merchantable trees are likely to be benefited by the cutting. From this enumeration the forester is able to make a table of percentages of trees of different sizes which show an increased rate of growth. With the table of percentages he combines the two previous tables of growth. If his table of percentages show that 20% of the trees will probably

be benefited by the removal of the old timber and 80% of them will not, then his combined average table of growth will be made up of 80% from the first and 20% from the second table.

This average table can then be applied directly to the growth of trees of different diameters. The following table was constructed in this way:

AVERAGE RATE OF GROWTH IN DIAMETER AT THE STUMP
OF SPRUCE.

[Based on 1593 Trees on Cut-over Land at Santa Clara, N. Y.]

Diameter, Breast- high, Inches.	Number of Trees Measured.	Number of Trees showing Increased Growth after Cutting.	Annual Diameter Growth of Trees not showing an Increase, Inches.	Annual Diameter Growth of Trees showing an Increase, Inches.	Average Annual Diameter Growth, including all Trees, Inches.	Number of Years Required to Grow One Inch.
5	8	1	.095	.100	.09	11
6	158	16	.080	.180	.10	10
7	329	63	.090	.185	.109	9
8	350	77	.105	.205	.125	8
9	277	59	.120	.205	.140	7
10	226	50	.135	.215	.150	7
11	135	18	.130	.210	.160	7
12	64	7	.165	.240	.170	6
13	30	2	.165	.170	.178	6
14	11	1	.150	.200	.185	6
15	1		.080		.192	6
16	4		.200		.200	5
Average			.112	.20	.137	7

160. Study of the Growth of Trees in Area.—By growth of a tree in area is meant the increase at a given cross-section, expressed in square feet or other unit of square measure.

Tables of growth in area are not commonly made in this country, not having been required in many of our practical problems. The growth in area for short periods is, however, frequently used in predicting the increment in volume.

In reality the area growth shows the real capacity of the tree

better than the diameter growth. Diameter growth shows the energy of radial cell division, but the area growth gives a measure of the actual amount of wood produced at a given cross-section. This is well illustrated in a comparative study of the growth at different parts of a tree. Thus in a forest tree which is growing in a crowded stand the growth in diameter increases from breast-height up to the base of the crown, whereas the growth in area remains practically the same. This increase in diameter growth is due to the fact that the stem tapers and a given amount of material produces wider rings than where a greater surface must be covered. The amount of material produced at different points is, then, shown better by the increase in area than by that in diameter.

A study of the rate of growth in area involves no difficulties because the results are obtained from a study of diameter growth by substituting for all diameters in the final tables the areas of corresponding circles.

161. The Growth in Height of Individual Trees.—The rate of growth in height is used in computing the rate of growth in volume. There are many occasions when one desires the rate of growth of a specified group of trees, as, for example, the growth of white pine over spruce, spruce under pine, hemlock under oak, spruce in swamps compared with that on slopes, and so on; an immense list of problems. In establishing plantations the forester has to know the relative rate of height growth of the different trees in order to mix the species which will best thrive together. For example, a slow-growing intolerant tree would not be planted with a more rapid-growing species. Thus, if pitch pine and white pine were planted together, the former would eventually be overtopped and die. A knowledge of the relative height growth would prevent such an error. The forester requires also a knowledge of height growth in the work of improvement cuttings. There are many occasions when the selection of a tree in making thinnings depends on its growth in height. This is particularly true in young growth, for example, where

it is a question of saving a slow-growing tree which stands among more rapid-growing ones. Frequently one has to make a heavy opening of the stand in order to save such a tree. Again, a forester, ignorant of height growth, might often expend labor in trying to save a tree growing among other species, when, if left alone, it is capable of growing rapidly enough to hold its own.

Experiment has shown that under ordinary circumstances the height growth of trees is an excellent index of the quality of a given site; that is, where the conditions of climate and soil are most favorable for the life of a species, there the height growth is the greatest, unless some modifying factor checks the development of the trees. The average growth in height of trees is, therefore, determined to assist in judging the quality of the site. (See page 325.) Care should be exercised in constructing and using tables of height growth of individual trees designed to aid in judging the quality of the site. Where trees are scattered individually among others the height growth may vary considerably, even on the same class of soil. For example, a red oak in mixture with pine might grow differently than when mixed with white oak or hard maple, or a pine in mixture with oak might grow in height differently than when growing in pure stands. It is well known that trees grow in height somewhat differently in very open and in crowded stands. This is particularly true in early youth when the height growth is frequently checked by overcrowding. A too-open stand also acts as a check to height growth. Separate tables must therefore be made, not only for different soil classes, but also for other conditions where there is a characteristic height growth. In making tables of height growth of individual trees, their practical purpose must always be kept clearly in mind, exactly as in the study of diameter growth. Haphazard figures of height growth are not suited to general conclusions.

162. Determination of the Rate of Growth of Trees in Height.

—It has been explained that the age at a given cross-section of

a tree represents the number of years required to grow from that point to the tip. The age at the stump may not be the age of the tree from the seed, but only the age of the portion of the tree above the stump, and in the same way the age at the top of the first log is less than at the stump. The ages at different cross-sections from the base toward the tip are, therefore, suc-

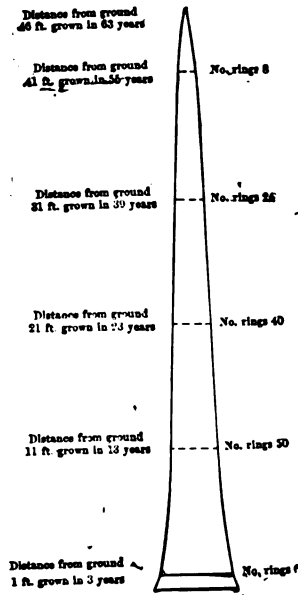

FIG. 48.

cessively smaller, and the difference in the number of rings at two cross-sections is the length of time required to grow the distance between them.

A full analysis of a tree furnishes the data necessary for a study of its height growth. Where the rate of growth in height alone is desired, it is necessary to determine the number of rings at each cross-cut and the length of each log or piece, including the length from the last cross-cut to the tip of the tree

and the height of the stump. For example, on the tree represented in Fig. 48 the following measurements are taken:

Height of stump, 1 foot; piece above last cut, 5 feet; lengths of the other four logs, 10 feet each; number of rings at the stump, 60; at the second cross-cut, 50; at the third cross-cut, 40; at the fourth cross-cut, 24; and at the top cross-cut, 8.

These are the data necessary to make a table of height growth for the tree, except that it is not known how long it took to grow the first 1 foot; that is, from the seed to the height of the stump. By an investigation of the height growth of seedlings, like that explained on page 245, it was determined that the average time required to grow 1 foot under the prevailing conditions was 3 years. The total age of the tree is, therefore, the age at the stump plus 3 years, or 63 years. From these data the conclusions which are shown on the left side of the figure, are drawn, namely that the tree grew 1 foot in 3 years; that it grew the length of the first log in 60-50, or 10 years, making the tree 11 feet high at 13 years of age; that it grew the length of the second log in 50-40, or 10 years, making the tree 21 feet high at 23 years of age; that it grew the length of the third log in 40-24, or 16 years, making the tree 31 feet high at 39 years of age; that it grew the length of the fourth log in 24-8, or 16 years, making the tree 41 feet high at 55 years of age; and that the tree grew the last 5 feet in 8 years. The rate of growth of the tree is shown in the following table:

Age, Years.	Height, Feet.	Age, Years.	Height, Feet.
3	1	39	31
13	11	55	41
23	21	63	46

This table is not in a convenient form because it is based on irregular age periods. It would be more useful if it showed

the growth in height for even decades. Such a table may be constructed by graphic interpolation. The values in the above table are plotted on cross-section paper whose abscissæ represent years and whose ordinates represent feet. A curve is drawn through the points and new values read from it for even decades as follows:

Age, Years.	Height, Feet.	Age, Years.	Height, Feet.
10	9.5	40	31.6
20	19.5	50	37.8
30	26	60	44.8

If a large number of trees are to be averaged together, the values of each tree are plotted on the same sheet of cross-section paper and an average curve drawn through the points. From this curve a table is constructed showing the average height of trees of different ages.

163. Height Growth of Even-aged Stands.—Tables of height growth of stands show the average heights at different ages. By the average height of a stand is usually meant the arithmetic average of the heights of the trees in the stand. Most investigations requiring a determination of the height growth of stands include also the determination of the volume growth based on the measurements of sample plots. If the volume on a given sample plot is to be determined by the mean sample-tree method, Draudt, or similar method, the average height of the test trees is used as the average height of the stand. If the arbitrary group method is used, the average height is obtained by the formula

$$\frac{n_1 \times h_1 + n_2 \times h_2 + n_3 \times h_3 + \dots}{N},$$

in which N is the total number of trees and n_1 and h_1 , n_2 and h_2 , etc., are the number of trees and average height of the test trees, respectively, in the different diameter groups.

Sometimes the geometric average height is determined, such as would result from the formula

$$H = \frac{b_1 \times h_1 + b_2 \times h_2 + b_3 \times h_3 + \dots}{B},$$

in which H is the average height, B the total basal area, b_1 and h_1 , b_2 and h_2 , etc., the basal area and the average height, respectively, of the different diameter groups.

After the average heights of a large number of sample plots taken in stands of different ages have been determined, they are averaged together by a height curve based on age.

Another method is first to construct a table of maximum height growth and then by a study of average differences between the maximum and average height of stand different ages reduce it to a table of average heights. It has been found by experiment that the trees which are the tallest in youth remain so through the life of an even-aged stand; in other words, that the tallest trees in a mature stand have always been the tallest trees throughout the life of the stand. Therefore, if a small number of trees of maximum height in a merchantable stand be felled and analyzed, the maximum-height growth throughout the life of a stand may be determined. It has been found, also, that in even-aged stands of a given species growing in a site of given quality, the difference between the average and maximum height is very uniform at any given age. This principle furnishes a simple method of determining the average height growth of stands. One requires only to measure a few maximum trees in the old stands and from them make a curve of maximum-height growth; then by a few measurements in the woods or from test trees, determine the average difference between the maximum and average heights of stands of different ages. No studies have been made of this problem in this country. A good illustration from Europe is the relative maximum- and average-height growth of Scotch Pine. The table on page 289 is furnished by Weise's study of the Scotch Pine in Germany.

164. The Growth in Height of Trees of Different Diameters.

—Sometimes the rate of growth in height is determined for trees of different diameters, just as the current rate of growth in diameter is determined for trees of different sizes. Thus, for example, one may desire to know not only how fast the 10-inch trees grow

in diameter, but also how fast they grow in height. Usually one determines the periodic annual growth for the last 5 or 10 years. To determine this, one either counts back the whorls

DIFFERENCE BETWEEN THE AVERAGE AND MAXIMUM
HEIGHTS OF SCOTCH PINE STANDS.*

Average Height, Meters.	Excess of Maximum over Average Height, Meters.	Average Height, Meters.	Excess of Maximum over Average Height Meters.
4	0.6	18	1.8
6	0.8	20	1.6
8	1.0	22	1.6
10	1.3	24	1.6
12	1.7	26	1.6
14	1.7	30	1.5
16	1.7		

at the tip of a felled tree which is being analyzed, or if the recent growth cannot be determined by the recent annual shoots, one cuts off as much from the tip as he thinks will probably represent the growth of n years. The count of rings at the cross-section indicates the age of the piece cut off. The mean annual growth in length of this piece is determined, even if it does not represent exactly n years. Suppose, for example, that one is endeavoring to determine the mean annual growth for the last 10 years. If some of the tips represent a growth of 8 years, others 11, or other ages thereabouts, the mean annual growth is obtained in each case and averaged together, and one does not take the time and trouble to find the point where the age is exactly 10 years.

Another study which has not been often undertaken, but which under certain circumstances might be carried on, concerns the rate of growth of trees of different heights. One may wish, for instance, to know the current rate of growth in height of 30-foot trees, 35-foot trees, 40-foot trees, etc.

* Ertragstafeln für die Kiefer, W. Weise, Berlin, 1880.

165. Study of the Rate of Growth of Individual Trees in Volume.—The ultimate object of nearly all study of growth is the prediction of future yield in volume, whether of individual trees or of whole stands. Studies of diameter growth usually give incomplete answers to given problems. Thus one may determine from an investigation of diameter growth that under a given set of conditions a specified tree or stand will become merchantable in 40 years. Such a study, however, does not show the volume of the tree or stand produced in the given period. Studies of diameter growth are chiefly valuable as a step in the study of volume growth or as a substitute for volume growth when it is impossible to carry on an investigation of the latter.

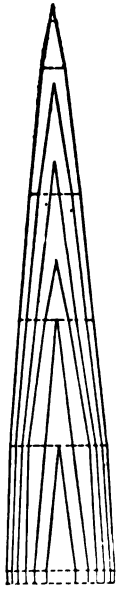

FIG. 49.

A full tree analysis furnishes the data required to determine the rate of growth in volume of a single tree. From the tree analysis one may determine the dimensions of the tree 10 years ago, 20 years ago, 30 years ago, etc., and from these measurements compute the volume (without bark) which the tree had at these different periods. Suppose, for example, that the volume growth of the tree represented in the tree analysis shown on page 264 is to be calculated, and that the computation is to include the growth in cubic feet of the wood (without bark) of the entire stem. The present cubic contents are first computed, each log being cubed as a truncated paraboloid, the stump as a cylinder, and the tip as a cone, as described in section 62. The cubic contents of the tree 10 years ago are then determined. The diameters 10 years ago at the various cross-cuts are obtained by multiplying the average radii of 10 years ago by 2. Thus the average radius on the stump 10 years ago, as shown in the form on page 264, is 3.95 inches and the diameter 7.9 inches. The stump-height and the lengths of the first three logs are the same

COMPUTATION OF THE VOLUME GROWTH OF A RED OAK.

Cross-cut.	Diameter Inside Bark, Inches.	Area, Sq. Ft.	Section.	Length, Feet.	Volume, Cu. Ft.
TREE 60 YEARS OLD.					
1	8.5	0.394	stump	1	0.39
2	7.6	0.315	1st log	10	3.54
3	6.0	0.196	2d log	10	2.56
4	4.0	0.087	3d log	10	1.41
5	1.6	0.014	4th log tip	10 5	0.50 0.02
Total					8.42
TREE 50 YEARS OLD.					
1	7.9	0.340	stump	1	0.34
2	6.8	0.252	1st log	10	2.96
3	4.6	0.115	2d log	10	1.83
4	2.5	0.034	3d log tip	10 8.75	0.74 0.10
Total					5.97
TREE 40 YEARS OLD.					
1	6.9	0.260	stump	1	0.26
2	5.9	0.190	1st log	10	2.25
3	3.1	0.052	2d log	10	1.21
4	0.6	0.002	3d log tip	10 2.5	0.27 0.00
Total					3.99
TREE 30 YEARS OLD.					
1	5.7	0.177	stump	1	0.18
2	5.0	0.136	1st log	10	1.56
3	1.8	0.018	2d log tip	10 4.75	0.77 0.03
Total					2.54
TREE 20 YEARS OLD.					
1	4.2	0.096	stump	1	0.10
2	2.0	0.022	1st log tip	10 10	0.59 0.07
Total					0.76
TREE 10 YEARS OLD.					
1	2.4	0.031	stump tip	1 10	0.03 0.10
Total					0.13

as those of the present tree. There was no fourth log because the tree did not reach up to the last cross-cut of the present tree, as is indicated by its having only eight rings. The length of the tip of the tree 10 years ago is obtained by proportion. The age at the fourth and fifth cuts of the present tree are respectively 24 and 8 years; that is, it took 16 years to grow the length of the log, or 10 feet. The annual growth was, then, $\frac{10}{16}$, or 0.625 feet. The age at the fourth cut, a decade ago, was 14 years; that is, the tip was 14 years old and 8.75 (that is, 14×0.625) feet long. The dimensions of the tree at other periods are determined in the same way.

The dimensions of the tree in question now, 10 years ago, 20 years ago, etc., are shown in the table, on page 291 and are represented graphically in Fig. 49.

The computation just described shows the volume of the tree when it was 10, 20, 30, 40, 50, and 60 years old *on the stump*. If, as explained in section 162, it is assumed that the whole age of the tree is 63 years, that is, that 3 years were required to grow from the ground to the stump-height, then the results of the computation would show the volume of the tree 13, 23, 33, 43, 53, and 63 years of age, as shown in the following table:

Age at the Stump.	Age at Ground.	Volume without Bark, Cu. Ft.
10	13	0.13
20	23	0.76
30	33	2.54
40	43	3.99
50	53	5.97
60	63	8.42

It would then be necessary to interpolate the volume at even decades by a curve just as described for heights on page 287. This interpolation gives the following table:

Age at Ground.	Volume without Bark, Cu. Ft.
10	0.12
20	0.68
30	2.26
40	3.92
50	5.70
60	8.10

If the average volume growth of a number of trees is to be determined, the volume of each tree at different periods in its life is computed as described above for the red oak. The average growth of all the trees is then determined by means of a volume curve based on age. This method gives the volume of trees without bark at different ages. If the volume with bark is desired, it is necessary to make separately a table showing the ratio of the volume of bark to volume of wood at different ages; and then to increase by these amounts the values in the table of volume growth.

In the illustration of a computation of volume growth, the total cubic feet of the stem at different ages have been determined. The method could be used perfectly well to determine the volume at different ages in board feet, cords, standards, or other measure.

166. Graphic Method of Determining the Average Volume Growth of a Group of Trees.—The method just described, of determining the volume growth of individual trees, is very laborious and time-consuming. Suppose, for example, that 1000 trees were analyzed and that they are on an average 100 years old. This would mean 10 calculations of volume for each tree, or 10,000 in all, in addition to the other required work of computation. On account of this long and expensive work relatively few studies of volume growth of individual trees have been made in this country.

A shorter method of studying the volume growth of a group of individual trees is to compare and average their rate of growth

in diameter at different points on the trunk, and from these data determine the dimensions of the trees at different periods, enabling the calculation of the growth in volume. This plan was described by A. J. Mlodjiansky in *Measuring the Forest Crop*,* and used by him in the study of white pine †, and in several other investigations whose results were never published.

Mlodjiansky's method is as follows:

1. Trees are selected for analysis in the ordinary way. Where possible the logs are cut in equal lengths.

2. The rings at the different cross-sections are counted and measured by decades from the pith outward.

3. A table of height growth is constructed showing the average time required for the trees to grow from the ground to the various cross-cuts.

4. Separate curves are constructed for the average growth in diameter at the stump and at all other cross-cuts. Thus a curve for diameter growth is made for the first cross-cut 12 feet above the stump, exactly as is done at the stump, and then for the other cross-cuts in the same way.

5. From these curves are determined the average dimensions of the trees at different ages. The stump curve gives the average stump dimensions throughout the life of the trees. From the curve for the next cross-cut may be determined the diameter, at that point when the tree was 10, 20, 30 years old, etc.; and in the same way the other curves contribute to the determination of enough additional dimensions for the computation of the average volume of the trees at different ages.

In determining from the curve for a specified cross-cut (for example 12 feet above the stump) what diameter is attained at a specified age of the tree, one finds the age of the 12-foot cross-cut corresponding to the specified diameter, and to this age adds the time required to grow from the ground to the cross-cut. Suppose, for example, that the height-growth table shows that

* Bull. No. 20, Div. of For. U. S. Dept. of Agric.

† Bull. No. 22, Div. of For. U. S. Dept. of Agric.

it takes 15 years to grow to the top of the first 12-foot log, and suppose that the diameter curve for the 12-foot cross-section shows that at 15 years the diameter is 6 inches, then one concludes that it takes 30 years for the tree to attain a diameter of 6 inches at 12 feet above the stump. In this same way one determines the diameter at all cross-sections at different ages (even decades) of the tree. Mlodjiansky represented the average growth at different cross-cuts graphically by diagrams.

167. Modification of the Method by the Author.—A modification of the method has been used by the author in a number of investigations. In the modified method the procedure is practically the same as described in the previous section up to the completion of the separate diameter curves. The next step is to enter all the curves *on the same cross-section paper*. The stump curve has its zero-point at the intersection of the vertical and horizontal axes of the rectangular co-ordinates. The curve for the next cross-cut has its zero-point to the right of the zero-point of the stump curve at the age (determined from the height curve) required by the trees to grow from the ground to that cross-cut. The curve of the third cross-section has its zero-point still further along the horizontal axis at the age representing the time required by the trees to grow to that height. The other curves are entered on the sheet in the same way.*

The combining of all curves in this way serves as a check in their construction and shows clearly the comparative growth at different points on the tree. The curves have the same general form, particularly above the stump. The stump curve diverges from the others, as a rule, because the current annual growth drops off more gradually. The breast-height curve has the form of the curves for the cross-cuts above the stump. If the curves (excepting the stump curve) are found to have marked differences, it usually indicates that an error

* In the study of the white pine, Mlodjiansky combined the different curves on one sheet, but all were started at a common zero-point (see Bull. No. 22, Division of Forestry).

has been made in constructing some one or more of them or that the data are unsatisfactory. The curves, when arranged on the same sheet, enable a ready determination of the dimensions of different cross-sections at various ages, and by interpolating new curves one may obtain the dimensions at any desired cross-sections other than those analyzed.

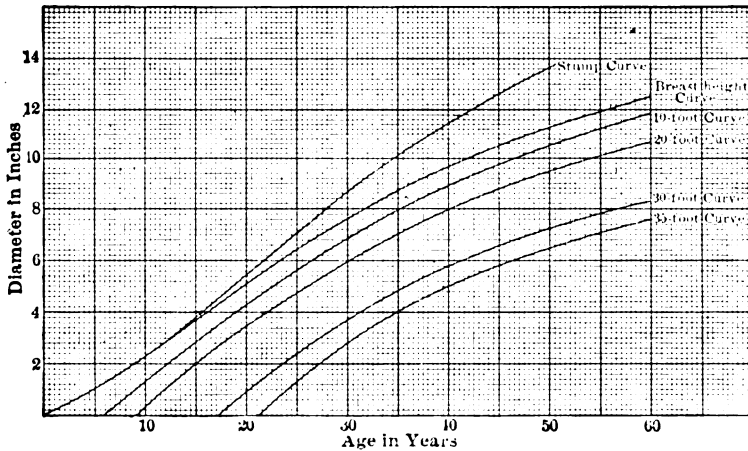

FIG. 50.—Curve, Showing the Growth of Chestnut.

Fig. 50 shows a set of curves for chestnut based on 10-foot logs. This diagram serves as a convenient picture of the life-history of the tree. If one wishes to know how soon a 30-foot pole 6 inches in diameter at the top will be produced, he follows by the eye along the horizontal line running from the 6-inch point (on the vertical line) to its intersection with the 30-foot curve. Project this point on the horizontal line and read the age. To find how long it takes to produce a 16-foot log 12 inches in diameter, one must interpolate a 16-foot curve between the 10- and 20-foot curves. This is done by dividing proportionately the vertical lines separating the curves, marking off on each a point 0.6 the distance from the 10-foot curve and connecting these points by a curve. From this 16-foot curve may be read off the length of time required to produce the 12-inch

log, or one may determine the diameter of the 16-foot log at any desired age. Usually a table is constructed showing the dimensions at specified cross-sections like that given below. The diagram is, however, of greater practical use, because it enables the quick determination of values not indicated in the table.

The following table was obtained from the curves in Fig. 50:

GROWTH OF CHESTNUT SPROUTS.

[Based on the Measurement of 39 Trees near New Haven, Conn.]

DOMINANT TREES IN THE FOREST.

Age, Years.	Diameter on Stump Inside Bark, Inches.	Diameter Breast-high Outside Bark, Inches.	Diameter at 10 ft. Above Stump Inside Bark, Inches.	Diameter at 20 ft. Above Stump Inside Bark, Inches.	Diameter at 30 ft. Above Stump Inside Bark, Inches.	Diameter at 35 ft. Above Stump Inside Bark, Inches.
10	2.1	2.1	1.35	0.3
20	5.4	5.1	4.3	3.4	0.9	...
30	8.7	7.65	6.9	6.1	3.7	2.9
40	11.45	9.7	8.9	8.0	5.8	5.0
50	13.7	11.3	10.6	9.5	7.25	6.5
60	12.5	11.9	10.7	8.55	7.6

It is often impractical to secure logs of uniform length. In this case separate curves are made for cross-sections which are at the same distance from the stump. Thus if trees cut by lumbermen are analyzed, one would probably have material for curves representing the growth at 12, 14, 16, 24, 26, 28, 30, 32, 36, etc., feet above the stump.

In the method just described the rings may be counted and measured from the pith out toward the bark, and the diameter measurements at any given cross-cut averaged together just as is done for stump measurements. The author has usually used the following plan in constructing the curves for the cross-cuts above the stump. Suppose, for example, that a curve is to be constructed for the cross-cuts, 10 feet above the stump, of a certain number of trees. The rings are counted by decades from the bark inward and measured as described on page 262. Then the measurements of each tree at the 10-foot cross-cut are plotted on cross-section paper, whose abscissæ represent the age of the tree (not the age of the cross-section). Suppose

that a cross-cut has 40 rings and a comparison of this age with the full age of the tree shows that 20 years have been used in growing from the ground to the cross-cut, then the zero-point of the cross-cut in question is at the 20-year point on the horizontal axis, and from this newly established zero-point the growth measurements are plotted as ordinarily. Every other tree has its independent zero-point for the 10-foot cross-cut. When all points have been plotted, a curve is drawn through them, which crosses the horizontal axis at a point to the right of the zero of the whole system of coordinates, a point which represents the average length of time required by the tree to reach the 10-foot cross-cut. Other curves are drawn in this way and finally compared as described on page 296.

The method of studying volume growth described above has the advantage of being much shorter than that described on page 290. If the work is not done by a skilled hand, the method is not so accurate as the more laborious and mechanical method usually advocated. Any method involving curve drawing is subject to inaccuracies when the work is done by one who is careless or inexperienced.

One of the problems in which the method is used to advantage is the study of the production of ties, posts, poles, mine timbers, or other material requiring special dimensions. In studying the yield in ties at different ages one measures the diameter growth at 8, 16, 24, 32, etc., feet above the stump and makes a series of diameter-growth curves which he compares on a sheet of cross-section-paper, whose abscissæ represent the full age of the trees. If 9 inches is the minimum top diameter of logs yielding first-class ties, note the ages at which the abscissa running from 9 inches cuts the 8-foot, the 16-foot, and 24-foot curves. They are the ages required to yield one, two, and three ties respectively. No stump curve is necessary.

168. Determination of Volume Growth for Short Periods.—It frequently happens that one wishes to determine the volume growth of individual trees for the last 5 or 10 years, but not during their whole life. The method described in section 165 may be used to determine the volume now and that 10 years ago, the difference being the required increment. To avoid the

labor of calculating the growth in diameter for the last 10 years at a number of cross-cuts and cubing the tree by sections, the following plan has been proposed. The present volume (without bark) is determined by multiplying the area (outside bark) at the middle of the stem by the length. That is (Fig. 51), $V = B \times H$. Then 10 years' growth is cut off from the tip. The length of 10 years' growth is determined by the whorls of branches in conifers, or if the annual growth cannot be distinguished from the outside, short pieces are cut off and the rings counted until the cut shows exactly 10 years' growth. Then the middle point of the reduced stem is found and the growth in diameter at that point is measured either on a cross-cut or by means of the increment borer. The area 10 years ago (b in Fig. 51) multiplied by the length of the reduced stem h gives the volume 10 years ago. The difference between the two volumes is the increment for the last 10 years.

This method assumes that the tree has now, and had a decade ago, the form of a paraboloid. This assumption is not correct, but the trees are probably so nearly equal in form that any error in computation due to their deviation in form from the paraboloid is the same in each and hence does not affect the increment.

169. Pressler's Modification.—To simplify the calculation in volume still further, Pressler proposed the following modifica-

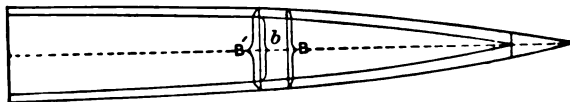

FIG. 51.

tion of the method just described: The tree is reduced in length by n years' growth. Then the middle point of the reduced stem is found and the area of the present tree (inside bark) at that point is determined. The area of the tree n years ago is ascertained at the same point and the volume of the present tree is

(Fig. 51) $V = B' \times h$; the volume n years ago is $v = b \times h$; and the growth in volume for n years is $V - v = (B' - b)h$. Pressler assumed that the loss of the tip in computing the volume of the present tree is compensated by taking the middle point on the stem lower toward the butt, where the diameter is larger. This method is less accurate than the previous one.

170. Determination of the Growth in Volume by Means of Form Factors.—

A tree is felled and its present volume determined by multiplying the length by the area at the middle point. From this volume is determined the form factor. The basal area of the tree at breast-height ten years ago is obtained by deducting the growth in area for the last ten years. The height of the tree ten years ago is obtained by cutting off ten years' growth from the tip of the tree and measuring the section remaining. The volume of the tree ten years ago is then obtained by multiplying the product of the basal area and height by the form factor of the present tree, it being assumed that the form factor of the tree now is the same as that ten years ago. This method is accurate, but still involves considerable calculation. To shorten it the following plan has been proposed: Determine the area at the base, multiply by the length and then by a form factor obtained from a form-factor table, such as those in the Appendix; then deduct from the present diameter at the base the growth for the last ten years and ascertain the basal area ten years ago. Cut off the last ten years' growth from the tip to determine the length of the tree ten years ago and multiply the product of the basal area and height ten years ago by a corresponding form factor taken from the form-factor table. The difference in the volumes represents the growth for the last ten years. This method may be applied to estimate the volume growth of standing trees. The height of the tree is measured with a height measure, the diameter at breast-height is measured with calipers, and the form factor obtained from the table. With the Pressler borer one determines the rate of growth for the last ten years and calculates the basal area ten years ago. The growth in height for the last ten years is estimated and deducted from the present height for the length of the tree ten years ago and the form factor is also taken from a table.

In all of these methods it is assumed that during the decade there is no change in form factor, which is not strictly true, particularly during the period of most rapid growth.

171. Estimate of Volume Growth in the Future.—Just as with diameter growth, one may assume that the volume growth in

the immediate future will be the same as in the last few years. If the current annual growth has not yet reached its maximum, an underestimate of future growth results; if the current annual growth is falling off, an overestimate is made. The estimate is accurate only when the current annual growth is neither falling nor rising.

Another way of estimating the future growth in volume is to determine the growth in diameter at different parts of a tree during the last five or ten years and assume that this growth in diameter will be the same during the coming five or ten years. By adding this growth an imaginary tree is obtained which may be cubed and compared with the present tree, the difference being the growth in volume which may be expected. This method gives too large results unless the volume growth is increasing. If the volume growth were the same as during the previous year, the annual ring would be smaller because the growth is necessarily spread over a greater surface.

Still another plan is to determine the growth in diameter for n years, then deduct one-half this growth from all cross-sections and cube the resulting stem; then add to the present dimensions one-half the growth for the last n years and cube the resulting stem. The difference is the growth in volume which may be predicted for the next n years.

This last method is the most accurate. The use of this method in predicting the growth of stands is explained on page 311.

172. The Rate of Growth Percent.—The growth of trees in diameter, area, height, or volume may be expressed as a percentage. In practice, however, only the rate of growth in area and volume is determined in percentage terms. The growth percent is based on simple interest, except when the increase in value is expressed in money, and then it is based on compound interest.

One of the greatest uses of the growth percent is in predicting future growth of a tree or stand. The product of the present

volume, determined by measurement or estimate, by the current annual growth percent gives the annual growth in volume. Thus, for example, if a stand has 40 cords per acre, and it is estimated that it is growing at the rate of 2 percent per annum, the growth at the end of the first year is 0.8 of a cord, or 8 cords in 10 years. Tables of growth in volume are often expressed in percentage terms like the following, which represents the growth of a single red oak:

Age.	Volume, Cubic Feet.	Annual Rate of Growth, Percent.
10..	0.8	
20..	2.2	17.5
30..	4.7	11.4
40..	7.6	6.2
50..	11.5	5.1

There are several methods of computing the growth percent. In the table given above the periodic growth percent for 10 years is obtained and the annual growth percent obtained by dividing by 10. Thus if V is the present volume, v that n years ago, and p the rate percent, then

$$v : \frac{V-v}{n} = 100 : p, \text{ or } p = \frac{V-v}{vn} \times 100.$$

In predicting growth for the future, this formula gives too large results because the growth percent decreases with increase of age. On the other hand, if the present volume V instead of v were used as the principal in the formula, an underestimate would often be obtained because the current annual volume growth of individual trees continues to increase up to an old age.

As a compromise it is customary to use as a principal, in the interest calculation, not the present volume or the volume n years ago, but the average of the two, or $\frac{V+v}{2}$. Substituting in the interest formula,

$$\frac{V+v}{2} : \frac{V-v}{n} = 100 : p, \text{ or } p = \frac{V-v}{V+v} \times \frac{200}{n}.$$

This method of calculating the rate of growth percent has been found so satisfactory for the ordinary problems of forestry that it is the principal method used in the preparation and revision of Government working plans in Europe.

Still another plan is to compare the present volume with that one year ago. Expressed algebraically, the volume one year ago is $V - \frac{V-v}{n}$, and the interest formula becomes, by substitution,

$$\left(V - \frac{V-v}{n} \right) : \frac{V-v}{n} = 100 : p, \text{ or } p = \frac{V-v}{V(n-1)+v} \times 100.$$

Pressler proposed to use the previous formula in calculating the current rate of growth percent of trees which have been reduced by cutting off the growth in length for the last n years as described on page 299. To simplify the work, however, he assumed that the rate of growth percent in area (at the middle of the reduced stem) is the same as the rate of growth percent in volume. He based this assumption on the following reasoning: In the formula for the growth percent in volume one may substitute for V and v the expressions $B' \times h$ and $b \times h$ (see Fig. 51). Then

$$p = \frac{B'h - bh}{B'h + bh} \times \frac{200}{n} = \frac{B' - b}{B' + b} \times \frac{200}{n}.$$

German foresters have investigated the accuracy of this formula and found that the growth percent in volume of the reduced tree is not the same as the rate of growth percent in area at the center, but on an average the same as the rate of growth percent in area at 0.4 to 0.45 of the length (measured from the butt). Therefore more accurate results are obtained if one cuts from the tip not n years' growth, but 1.3 n to 1.5 n years' growth, and in very old trees whose height growth is extremely small, 2 n to 3 n years' growth.

One may substitute in the above formula the values D^2 and d^2 for B' and b . If $\frac{\pi D^2}{4}$ and $\frac{\pi d^2}{4}$ be substituted in the formula for B' and b , then

$$p = \frac{\frac{\pi D^2}{4} - \frac{\pi d^2}{4}}{\frac{\pi D^2}{4} + \frac{\pi d^2}{4}} \times \frac{200}{n} = \frac{D^2 - d^2}{D^2 + d^2} \times \frac{200}{n}.$$

173. Determination of Volume Growth Percent of Standing Trees.—The rate of growth percent of a standing tree can be determined only approximately. A number of methods have, however, been devised for estimating the rate of growth percent in volume of standing trees, which are accurate enough for most practical purposes. In the succeeding sections two methods are described which are now used in Europe.

174. Pressler's Method.—Pressler used the formula described in section 172 to determine the growth of standing trees. He distinguished between three classes of trees: first, those mature or nearly so, in which the growth in height and change in form factor are so small as to be negligible; second, those which are still growing more or less vigorously in height, but are not changing in form factor; and third, those growing in height and also changing in form factor. In the first case he assumed that the growth percent in volume is equal to the rate of growth percent in area at the base; that is, that the growth percent in volume may be obtained by the following formula, in which D , H , F , and d , h , f are the diameters, heights, and form factors, respectively, of the tree now and n years ago.

$$p = \frac{\frac{\pi D^2}{4} H F - \frac{\pi d^2}{4} h f}{\frac{\pi D^2}{4} H F + \frac{\pi d^2}{4} h f} \times \frac{200}{n}.$$

But it is assumed that $H = h$ and $F = f$; therefore

$$p = \frac{D^2 - d^2}{D^2 + d^2} \times \frac{200}{n}.$$

To determine the growth percent in volume of a standing tree which is mature or nearly so, one measures the diameter at breast-height and then by the increment borer determines the diameter n years ago and applies the formula

$$p = \frac{D^2 - d^2}{D^2 + d^2} \times \frac{200}{n}.$$

In order to shorten the work of calculation, Pressler constructed convenient tables which enable the quick determination of the growth percent in the following way: Let $D - d$ be designated as a , and $\frac{D}{a}$, which Pressler called the *relative diameter*, be designated as q . Then $D = aq$ and $d = D - a = aq - a = a(q - 1)$.

By substitution of the new values of D and d in the formula

$$p = \frac{D^2 - d^2}{D^2 + d^2} \times \frac{200}{n},$$

there results

$$p = \frac{a^2 q^2 - a^2 (q - 1)^2}{a^2 q^2 + a^2 (q - 1)^2} \times \frac{200}{n} = \frac{q^2 - (q - 1)^2}{q^2 + (q - 1)^2} \times \frac{200}{n}.$$

Pressler constructed a table showing the values of the expression

$$\frac{q^2 - (q - 1)^2}{q^2 + (q - 1)^2} \times 200$$

for every value of q from 2 to 300. To use the table, one measures the diameter of a tree at breast-height and the growth for n years. He then divides the present diameter D by the diameter growth a , which gives the relative diameter, or q ; then he looks up in the table the value of

$$\frac{q^2 - (q - 1)^2}{q^2 + (q - 1)^2} \times 200,$$

corresponding to known value of g ; this divided by n gives the desired rate of growth percent in volume.

This method is applicable only to mature or nearly mature trees whose height growth has practically ceased. With such trees it gives satisfactory results. In the fine print following is described Pressler's method of determining the growth percent of trees which are growing in height. So many assumptions are made, however, that the methods are considered subject to great danger of inaccuracy.

If the height of the tree changes materially in n years, the formula shown above gives too small results. Pressler provided for this contingency in the following way:

Let V, H, F, D , and v, h, f, d be the volumes, heights, form factors, and diameters respectively now and n years ago; then

$$\frac{V}{v} = \frac{\frac{\pi}{4} D^2 H F}{\frac{\pi}{4} d^2 h f}.$$

Assuming that $F=f$, then $V:v = D^2 H : d^2 h$. Assuming, further, that the growth in height is proportional to that in diameter, that is, that

$$D:d = H:h \quad \text{or} \quad H = \frac{Dh}{d},$$

then by substitution

$$V:v = \frac{D^2 Dh}{d} : d^2 h \quad \text{or} \quad v = \frac{Vd^3}{D^3}.$$

Substituting this last value of v in the formula

$$p = \frac{V-v}{V+v} \times \frac{200}{n},$$

there results the formula

$$p = \frac{D^3 - d^3}{D^3 + d^3} \times \frac{200}{n}.$$

By the use of the "relative diameter," that is $\frac{D}{a}$ or q , this formula may be expressed as

$$p = \frac{q^3 - (q-1)^3}{q^3 + (q-1)^3} \times \frac{200}{n}.$$

Pressler also prepared a table showing the value of the expression

$$\frac{q^3 - (q-1)^3}{q^3 + (q-1)^3} \times 200$$

for all values of q from 2 to 300.

The results of this formula differ considerably from the previous one. As there are many trees whose growth would be greater than is expressed by the formula in which q has a coefficient of 2 and less than by the formula just described, Pressler constructed tables for different values of q in the expressions

$$\frac{q^{2\frac{1}{2}} - (q-1)^{2\frac{1}{2}}}{q^{2\frac{1}{2}} + (q-1)^{2\frac{1}{2}}} \times 200$$

and

$$\frac{q^{2\frac{3}{4}} - (q-1)^{2\frac{3}{4}}}{q^{2\frac{3}{4}} + (q-1)^{2\frac{3}{4}}} \times 200.$$

He went even further, and in order to provide for trees which are growing in height, and also changing in form factor from year to year, prepared a table giving the values of the expression

$$\frac{q^{3\frac{1}{2}} - (q-1)^{3\frac{1}{2}}}{q^{3\frac{1}{2}} + (q-1)^{3\frac{1}{2}}} \times 200$$

for different values of q . This last is called the maximum table, and that made for values of q^2 is called the minimum table. In using these tables one must judge by the eye whether the tree has nearly reached maturity or is growing more or less rapidly and then use the table which in his judgment most nearly fits the case.

175. Schneider's Method.—The following simple method of determining the rate of growth percent of standing trees was

devised by Professor Schneider of the forest school at Eberswalde in 1853. The method is applicable only to mature or nearly mature trees whose height growth has practically ceased and whose form factor is not changing from year to year.

The diameter at breast-height is measured outside the bark and then a boring is made with the increment borer to determine the number of rings represented in the last inch radius. The rate of growth percent is then obtained by the formula $p = \frac{400}{nD}$, in which D is the diameter at breast-height and n the number of rings in the last inch of radius.

Schneider's formula is derived in the following way: If n represents the number of rings in the last inch radius at breast-height, then the periodic annual growth during n years is $\frac{1}{n}$ inches. Let the present diameter be represented by D , then the diameter last year was $D - \frac{2}{n}$ and the diameter at the end of one year from now will be $D + \frac{2}{n}$.

The present volume of the tree is $\frac{\pi D^2 h j}{4}$, that one year ago was

$$\frac{\pi}{4} \left(D - \frac{2}{n} \right)^2 h j.$$

The growth for the last year is then

$$\frac{\pi D^2 h j}{4} - \frac{\pi}{4} \left(D - \frac{2}{n} \right)^2 h j = \frac{\pi h j}{4} \left(\frac{4D}{n} - \frac{4}{n^2} \right).$$

The growth percent is:

$$\frac{\pi D^2 h j}{4} : \frac{\pi h j}{4} \left(\frac{4D}{n} - \frac{4}{n^2} \right) = 100 : p,$$

$$p = \frac{400}{nD} - \frac{400}{n^2 D^2}.$$

If the growth be calculated on the basis of $d + \frac{2}{n}$ instead of $d - \frac{2}{n}$, then the following formula will result:

$$p = \frac{400}{nD} + \frac{400}{n^2D^2}.$$

The average between the two formulæ is taken, namely,

$$p = \frac{400}{nD}.$$

Inasmuch as Schneider's formula assumes that there is no change in height and no change in form factor, the results are very conservative. An attempt has been made to adopt the formula to rapid-growing trees by increasing the value of 400, but the resulting formulæ have little practical value.

The methods just described are satisfactory only with mature or nearly mature trees. There is no good method of determining the rate of growth percent of a rapid-growing tree except by cutting it down and analyzing it. Fully as good results are obtained by using average-growth tables as by applying Schneider's or Pressler's methods to fast-growing trees.

176. The Increment of Stands.—The increment of individual trees is studied chiefly to enable the determination of the increment of stands. The American forester is now confronted by a multitude of practical problems which require the determination of the future yield of stands in timber and in money returns.

Three main groups of problems may be distinguished: first the prediction of the increment of even-aged stands for short periods; second, the prediction of the yield of stands established on clearings by planting or by natural reproduction; and third, the prediction of the yield after lumbering in many-aged forests. The first problem is discussed in the following sections of this chapter; the second and third problems are considered under the head of Yield Tables.

177. Prediction of the Increment of Even-aged Stands for a Short Period.—Frequently in making a working-plan it is necessary to predict the increment for one or several years or for a decade. One of the most common problems is to determine whether a stand is adding increment rapidly enough to pay to leave it standing. In certain European countries, for example in Austria, the policy is to cut and reproduce a stand as soon as it ceases to yield a satisfactory rate of interest. This is called the financial maturity of the stand. To ascertain whether a stand is financially mature, one determines its value now and one year ago. If the difference represents a rate of interest less than what the owner demands, the stand is past maturity. If the interest is equal to the minimum required by the owner, it is just mature.

Another problem is where a stand is to remain for a certain number of years and the owner wishes to know what the yield will be at the end of that period. In organizing a forest under a working-plan it is customary to predict the yield of certain stands, which are to remain a decade or more, by computing their present volume and adding the increment for the period in question.

In the working-plans of some European countries it is customary to predict the yield at maturity of every portion of the forest. The final yield of stands which are young or middle-aged are estimated by the help of yield tables (to be described later), but the final yield of the nearly mature stands is determined by studying their present current increment.

The method of determining the current increment is best explained by an example. Suppose a pure stand of red maple sprouts covering 25 acres is to be cut clear in 12 years, what will be the final yield? If the stand is uniform in age and density over the whole area, one sample acre is selected to represent the whole. If there is some variation in the character of the timber, enough plots are taken to guarantee a good average. The plot is accurately laid off and the trees calipered, then the volume computed by one of the methods involving the felling of sample trees. Suppose that the mean sample-tree method is chosen

and that three test trees are cut. The rate of growth percent in volume is determined for each test tree by the formula

$$p = \frac{V-v}{V+v} \times \frac{200}{n}.$$

The average growth of the test trees is assumed to be the average growth of the stand. The volume growth of the stand for one year is, therefore, obtained by multiplying the stand's present volume by the growth percent. The volume growth for 12 years added to the present volume of the stand gives the yield at the proposed time of cutting.

If it is impractical to fell test trees on account of the lack of time or because great accuracy is not necessary, the rate of growth percent is determined from standing trees. The trees are calipered as before and the diameter of the average tree computed. Volume tables are used to compute the volume of the whole stand (see page 219). Three test trees are selected as before, but instead of felling them the forester determines the rate of growth of each for the last few years with an increment borer, and after measuring the diameter computes the growth percent by the formula $p = \frac{400}{nD}$ or by Pressler's method. This plan is, however, very inaccurate in second-growth hardwoods, as the trees are usually growing in height and changing in form. It is therefore better to determine the growth percent from sample trees whenever possible, unless one is working in mature forests.

If a stand is composed of several species the growth of each is computed separately. Thus in southern New England the sprout forests are nearly always mixed, and frequently as many as 10 species are represented on a single sample plot. The survey shown on page 312 is a representative plot taken in Connecticut. To estimate the growth of such a stand accurately one should determine separately for each species the diameter of the average tree, then fell one to three test trees of each kind and calculate the

growth as described above. This would give a very good estimate of growth for the particular stand in question, but the accuracy would not pay for the time required by such a long operation. One would determine the growth of such a mixed stand in order to estimate the growth of a larger area, using the plot as an average. But mixtures of trees vary so much that

PLOT SURVEY IN MIXED HARDWOODS.

Diameter, Breast- high, Inches.	Chestnut.	Red Oak.	Rock Oak.	Red Maple.	Black Birch.	Beech.	Poplar.
2	..	2	4	60	5	3	
3	1	4	24	35	2	1	
4	2	7	31	19	..	2	1
5	7	15	13	13	1		
6	22	9	6	1	..	3	2
7	34	13	16	1			
8	20	19	9				
9	5	13	3				
10	1	8	1				
11	..	6					
12	..	3					
13	..	1					
14	..	2					
15	..	1					

it is almost impossible to select a stand in which the percentage of each species in mixture is exactly an average of the whole area. It is therefore impractical to keep all the species separate in the estimate of growth of a mixed forest. The growth of each of the ruling species is determined separately and the rest are lumped together or are considered a part of the ruling class. In the example given above the red and rock oak and chestnut are kept separate. Together they constitute 65 percent of the stand. The other species are lumped together as a single species and one or more test trees used of a species which represents, in the forester's judgment, about an average. In the above example red maple would show about an average growth, so that after determining the average diameter of the various species taken together, one or more red maples are cut and used to

estimate growth. The volume of the several species which are lumped together may be determined from the maple test trees or from volume tables for the separate species.

In most cases the mean sample-tree method is the simplest for determining the growth of even-aged stands. Sometimes, however, the trees are not sufficiently uniform in growth to use this method. For example, one may wish to keep separate the dominant and suppressed trees. Then two or more groups are made instead of one. If a stand is even-aged, but on account of its broken character has several distinct tree classes, then it is desirable to estimate the growth of each class separately. In the same way, if a stand is not strictly even-aged, the different age classes may be kept separate and by felling separate test trees for each class the growth of each may be determined.

An illustration of stands in which it is necessary to estimate the growth of several classes separately is found on old pastures in New England which have grown up to hardwoods. One often finds old chestnut trees which started in the open, and in the same stand groups of younger trees whose growth is quite different. Usually these tree classes differ in diameter so much that the arbitrary group method may be used in the study of their growth. But if the diameters overlap, then the classes must be tallied in separate columns when the stand is calipered.

Another method of determining the future growth of a stand is to assume that it will grow in the future at the average rate it has grown during its entire past life; that is, instead of basing the future growth on the periodic growth for the past 5 or 10 years, it is based on the average growth during the whole past life of the tree. In other words, the mean annual increment of the stand is assumed to remain the same for a specified number of years.

To determine the mean annual growth of a stand the total volume is computed and then divided by the average age. This method gives only approximate results. During the period of rapid growth, the mean annual growth is less than the current

annual growth, and in later life it is greater. The method gives accurate results only at the period when the mean annual growth is equal to the current annual growth. Nevertheless it serves as a ready way of estimating increment and is often used. Thus in the sprout region of New England the yield of stands is sometimes predicted by a study of the mean annual growth. More often, however, yield tables are used, as they are much easier in application, and if applied judiciously, are fully as accurate as the method just described.

178. To Determine the Growth in Volume of an Entire Forest.—One of the important problems in organizing a forest, which is to be managed on the principles of forestry, is to determine its annual production. Usually two questions must be answered, namely, what is the rate of growth in volume over the whole tract? What will be the merchantable yield of the tract in a specified period?

The rate of growth in volume over the whole forest is used in determining the amount of timber which can be cut annually or periodically without reducing the productive capacity of the forest. In practice the mean annual rather than the current annual growth is used. If the forest is composed of even-aged stands, as in the mixed hardwoods of Connecticut, the procedure is as follows: The tract is divided and subdivided into so-called compartments and subcompartments, enabling the study of each part of the forest separately. The final yield at maturity of each subcompartment is estimated and the mean annual growth computed by dividing this yield by the final age. The mean annual production of all subcompartments taken together constitutes the annual production of the forest. In a many-aged forest, managed on the selection system, the yield of each division of the forest at the end of a specified cutting period is calculated. This yield divided by the number of years in the period is the mean annual growth. The total annual production of the whole forest is the sum of the results found for the separate divisions. The method of determining the yield in many-aged stands at

the end of a specified period is described in section 198. The application of these studies of growth in regulating the annual or periodic cut constitutes a part of forest management and its discussion is not germane to the present work.

The other question, namely, what amount of timber can be cut in a specified period? involves the prediction of future yield for separate portions of a forest based on periodic growth for the last five or ten years. The divisions which are likely to become merchantable within the specified period are studied and the future yield predicted by the methods described in section 174 for even-aged stands and in section 198 for many-aged stands. The prediction of yield in different parts of a forest is made in the preparation of working plans and is discussed in books on forest management.

CHAPTER XVII.

YIELD TABLES.

179. Definition of Yield Tables.—A yield table is a tabular statement of the yield per acre, at different periods, of a forest of a specified character growing on a specified class of soil and treated under a specified method of management. Usually yield tables show the future product of stands, and in this book the term when used alone will have that meaning. The Society of American Foresters has adopted the terms *future yield table* for one showing future products, and *present yield table* for one showing the present stand.

2
1 | In this country we also distinguish between *yield tables for even-aged stands* and *yield tables for many-aged stands*. The first show the product, at different ages, of stands which have been established on clearings, and which are even-aged or nearly so. The second class of yield tables show the yield per acre of many-aged forests after the large trees have been removed under a specified system. The last are often also called increment or growth tables. They are, however, properly called yield tables because they show the product per acre at different periods of a forest treated under a specified system of management.

180. Yield Tables for Even-aged Stands.—As yet only one or two attempts have been made in this country to construct yield tables for even-aged stands. On the other hand, the yield tables abroad are altogether for even-aged forests, because the bulk of the forests are the result of planting or systematic natural reproduction on areas cleared at one time or within a short period.

American foresters have been inclined to regard such tables as less important than the yield tables for many-aged forests. It should be remembered, however, that there is in the aggregate an enormous area of second-growth forest throughout the country which is even-aged or approximately even-aged, and that this area is being constantly increased through fire, cutting, abandonment of old fields, and planting. The forester is handicapped on all sides by the lack of yield tables, both in deciding upon the introduction of forestry on given tracts and also in the work of making thinnings and in making working-plans. The first yield tables of this character in this country were made in 1894 for the white pine by Gifford Pinchot and the present writer. Since that time conditions of lumbering have changed, and the tables should be replaced by a more exhaustive study.

The list of instances in which trees are growing in even-aged stands would include not only all plantations, but the old clearings made by fire, windfall, clear-cutting, and the abandoned fields. Nearly every species which has light seed may be found in even-aged stands of greater or less extent, and many of the heavy-seeded trees occur as even-aged sprout stands after clear-cuttings, as, for example, in southern New England.

The methods used in making yield tables for such stands will necessarily be very similar to those used in Europe. The American should, therefore, understand European methods, and it is then a simple matter to make such modifications as are required by the circumstances.

181. European Yield Tables.—It is customary to distinguish between *Normal* or *Index* and *Empirical Yield Tables*. By a *Normal* or *Index Yield Table* is understood a table showing the yield, at different ages, of fully stocked stands. *Empirical Yield Tables* are based on stands which represent an average of the whole forest, including the poorly stocked as well as the best areas.

Yield tables are further distinguished as *local* and *general*. Local yield tables are based upon data gathered in a restricted

locality, and have only a local value. General yield tables are based upon data from a large area, such as a State or whole country. For example, Wm. Weise's yield table for Scotch pine is a general yield table based on data from all over Germany and designed for general use. On the other hand, Landolt's yield tables for the Zihlwald are based on Zihlwald figures and are not strictly applicable elsewhere.

In Germany the question of the correctness of general yield tables has been frequently discussed. The general yield tables for entire Germany are now distrusted, and the tables for more restricted regions are substituted for them. It is sometimes difficult to decide whether the results of studies in different regions differ because of the different factors of growth or because of the difference in silvicultural treatment or difference in methods of investigation. It is almost without doubt, however, that even in Germany the conditions for growth differ enough to make separate yield tables advisable. For example, the yield of spruce in central and southern Germany differ by a considerable amount; and Schwappach found marked differences in the growth of pine in different parts of Germany. If this is true for Germany, it must be doubly important in the United States, where there are wide climatic and geological differences which cause a variation in yield of a given species. It is a good rule in this country to make separate yield tables for different forest regions. Thus normal yield tables for white pine should be made separately for New England, the Appalachian region, and the Lake States; and investigation may show a still further restricting of the localities to be necessary.

182. Normal Yield Tables.—Normal yield tables show the product of fully stocked stands. By a normal or fully stocked stand is meant one with the average maximum yield actually obtainable with a given species under a given method of treatment in a given quality of site. Normal yield tables show the average maximum yield which results on an area fully stocked by planting or natural seeding, and undisturbed during the stand's

life by fire, wind, cutting, insects, or other causes. It is therefore a yield actually obtainable if the forest be successfully protected from disturbing factors, instead of a theoretical yield, which can seldom be secured.

It is very difficult to determine by the eye whether a stand is normal or not. One who has had experience with the species in question can, however, judge of the normality of a stand with sufficient degree of accuracy for purposes of general description, and in order to use normal yield tables.

In gathering data for yield tables, it is not always possible to determine in the field whether a stand is normal or not. Therefore the forester measures such stands as seem to him *as fully stocked as possible*. These stands are later compared at the office, and those which deviate too far from the average are discarded as not normal. The rule given by Professor Baur to determine whether stands are normal is as follows: Stands which have the same age and average height are compared, and all are considered normal whose total basal area lies within a range of 15 percent; that is, the basal area of the best- and poorest-stocked stands must not differ more than 15 percent. Nearly always there are some stands whose basal total area is too great; that is, which are abnormally well stocked. These are considered abnormal, just as those which are not sufficiently stocked. This rule is based on the assumption that a comparison of the basal areas of the stands is equivalent to a comparison of the volumes. As explained in section 127, the volumes of trees in even-aged stands vary so nearly as their basal areas that errors due to deviations from this law are negligible. The actual number of trees per acre cannot be taken as a measure of normality, because two stands of the same height and the same age may be normal, but have a different number of trees. On the other hand, if normal, they would have approximately the same basal area, at least within 15 percent.

The standard normality represents the best that actually exists and not the best that might exist under ideal conditions.

Normality of stand is, therefore, relative rather than absolute, and as the yield of forests is improved by scientific management, the conception of normality of a given species changes. Thus the normal yield of plantations which are to be thinned through life is larger than the normal yield of stands which will not be thinned at all or not often enough.

In preparing normal yield tables, one presupposes a specified system of management and aims to show the average maximum yield of fully stocked forests under those conditions. It is, therefore, entirely proper that there should be two sets of normal yield tables in this country: first, for fully stocked stands which are correctly thinned, and second, for stands not thinned.

183. Contents of Normal Yield Tables.—The most important part of the tables is the yield in timber at different ages. In addition, the tables contain the average number of trees per acre, the total basal area, the average height, and diameter of the average tree. Generally they contain also the growth percent and the forest form factors. Most European yield tables give the total cubic contents of the main crop, including all wood 7 centimeters and over in diameter, and also the volume of the subordinate trees which may be removed by thinnings.

The average height is included chiefly as a guide to the forester in judging the quality of the site of given stands. It has been found that the best qualities give the greatest height, and, *vice versa*, the poorest qualities give the poorest height growth.

The only cases where this is not true are where a stand is too much crowded or is too open. If a forest has been thinned like those in Europe, this stagnation of height growth by overcrowding does not occur.

The average diameter is given as an indication of the class of timber produced. It differs so much with different stands that it cannot be used as an index of the quality of the site.

It is of value to know the number of trees required to secure the total product, and it is a help in estimating the probable cost of cutting the timber. The number of trees per acre enables a

comparison of the relative tolerance of side shade of different species and rapidity of the reduction of trees from period to period.

The total basal area is used in practice to test the normality of stands. If a wind has entered a stand and it is found by calipering that the basal area is only 40 percent of the yield table, the volume will also be about 40 percent of the volume in the yield table, on the principle that the volumes of stands vary approximately as the basal areas.

The forest form factor is used to estimate volume of stands. The contents of a specified stand is found by multiplying the total basal area by the product of the height and the form factor (taken from the yield table).

In the Appendix several yield tables for European species are given. A number of columns have, however, been omitted as unnecessary for the purposes in hand, namely, the yield of material below 7 centimeters in diameter and the annual growth in height and volume.

184. Uses of Normal Yield Tables.—The practical uses of normal yield tables are as follows:

1. The prediction of the future returns on an investment in planting. The tables show what may be expected at different ages, provided no damage is suffered from fire or other adverse causes. They show how soon merchantable timber may be obtained, and by allowing a reasonable amount for damages, one may make a conservative estimate of the money returns on an investment.

2. The prediction of the future yield of young or middle-aged stands. The value of immature stands lies chiefly in their possibility for future returns. Yield tables enable the prediction of the future returns and hence the correct valuation of such stands. This is of great use in the purchase and sale of second growth, and in damage suits where young growth has been injured or destroyed. In applying the tables a discount must be made if the immature stands are obviously not fully stocked. The forester estimates the degree of stocking and assumes that the

*what
uses*

ratio of the stocking to the normal will be the same at maturity as now.

3. An estimate of the contents of stands. This is done by estimating the age and the degree of stocking and then taking the yield per acre from a yield table. If an even-aged stand of loblolly pine is 0.8 stocked and is 30 years old, the yield per acre is 80 percent of that shown in the yield table for 30-year-old stands.

4. The determination of the quality of a specified site for the growth of timber. The volume, basal area, or height of normal stands indicate the quality of the site. Suppose one owns a forest and wishes to determine the quality of site, as is often necessary in making a detailed working-plan. The height and age of a portion of the stand which is fully stocked is compared with the heights for the age in question in the yield tables, and the quality which has the nearest height ascertained. The total basal area or volume of a sample plot would serve still better than the height to determine quality of locality, but this would take too much time unless sample plots were taken for some other purpose.

5. The determination of the financial rotation of forests, their expectation value, and their normal yield and growing stock, and the solution of many other problems of forest management.

185. Collection of Data to Construct Yield Tables.—Normal yield tables are based on the measurement of a large number of sample acres in fully stocked stands of different ages, growing in different sites. The most satisfactory results are obtained by taking repeated measurements, at intervals of about five years, of permanent sample plots. We require, however, yield tables at once, and cannot wait for 10 to 30 years for the results of the periodic measurements. Therefore a large number of sample plots are measured in normal stands, as they are to-day, and from them the yield tables are constructed. This method is described in the following pages with particular reference to the European practice. The plan of work is as follows:

First, to select a large number of sample plots of different ages which are normally stocked.

Second, to determine accurately the contents of these sample plots.

Third, to determine the quality of the site to which each plot belongs.

Fourth, to construct curves for the contents per acre of stands of different ages in sites of different quality.

Fifth, to construct curves for height, basal area, and number of trees per acre, and to compute any other information desirable for the table, such as the forest percent and the form factor.

Sixth, to tabulate all results in the final yield table.

186. Selection of the Sample Plots.—The plots are located in fully stocked stands of different ages and sites of different quality. As explained in section 182, it is difficult to determine by the eye whether a stand is fully stocked or not. Two trained investigators would often differ in their judgment of the normality of a stand, and sometimes a plot which appears at first fully stocked proves defective upon further examination. Therefore the fieldmen select for measurement plots which *appear* to them fully stocked. The final decision as to the normality of the stands is reserved until their total basal areas can be compared. In Europe it is easy to find normally stocked stands, for most of the state forests have been under management for many years, and even the mature forests were in most cases established under a forester's care.

The plots are distributed among stands of different ages from 10 years up to maturity. The greatest proportion of plots is located among the old and middle-aged stands. Those under 30 years old are less important, because, even in intensively managed forests, the product of thinnings is small before that time and the final yield is seldom used in practice.

The plots are located in sites of different quality. The forester cannot always determine by the eye the quality of a given site,

but he can estimate it closely enough to enable him to include all qualities in the valuation areas.

187. Necessary Number of Sample Plots.—In general 150 plots are considered a minimum number, when five qualities of site are distinguished, and where the tables are designed for a relatively small State or county. For general yield tables more must be used. Modern European yield tables are based on 150 to 450 valuation surveys, a part being repeated surveys of permanent sample plots.

188. Thinning of the Stand before Measurement.—European yield tables show the product of thinnings as well as of the yield of the main stand. Before the trees are calipered, a thinning is marked, so that the two classes of trees may be kept separate in the tally and their volumes computed separately.

189. Measurement of the Plots.—The rule in Europe is to lay off whole hectares, but in practice a portion of the plots used are $\frac{1}{2}$ and $\frac{1}{4}$ hectare. The plots are usually square, and are surveyed out with accuracy, with boundaries distinctly marked. The calipering is done with great care, each tree being measured two ways or half the trees measured east and west and the other half north and south. After the calipering, test trees are felled for the computation of volume. Usually the Urich method is used, but recently the volume curve method has been introduced, notably in Austria. The number of test trees ranges from 9 to over 20.

190. Description of the Sample Plots.—As a rule in Europe the description is considered subordinate. This is because pure stands are chosen which are even-aged, normally stocked, and in good thrifty normal condition. There is, then, really nothing to describe except the soil. And since the quality of the site is judged entirely by the product, and not by the soil's appearance, the description is not absolutely necessary. It is only where one is trying to separate regions of growth that this becomes necessary. In Schappach's tables for the Scotch pine, there is no description whatever. Other tables generally contain the follow-

ing points: Elevation, aspect, degree of slope, geological formation, kind of soil, its depth, consistency, and degree of moisture. When tables are published the results of the measurements and also the description are given in a tabulated form, so that the results from the figures can be traced back by students and experts if desired.

191. Construction of the Tables.—The first work in the office after collecting the field data is to compute for each plot (in whole hectare or acre terms) the total yield, basal area, number of trees, average age, height, diameter, and form factor. The next step is to assign the different plots to their proper qualities of site. And it is exactly this point about which many authors disagree.

The simplest method is that of Baur, called the method of bands. The total yield in cubic measure of each stand is plotted on cross-section paper, whose ordinates represent final yield of the main crop in cubic measure and whose abscissæ represent the average age of the stands. As each point is plotted, the number of the valuation survey is also entered near it. Then regular curves are drawn through the maximum and minimum points, confining all the points in a comet-shaped band whose outer edges represent the maximum and minimum yield. Then the ordinates at each decade lying between these curves are divided into five equal parts, and the dividing points are connected by curves which separate the points representing the yield of the different plots into five divisions. The points lying in a single band indicate plots which belong to the same quality of site.

A modification of the method just described is to use heights instead of volumes to determine the quality of the site. After the heights on all the plots have been determined they are entered on cross-section paper whose abscissæ represent age and ordinates height. A maximum and minimum curve are drawn and then intermediate curves are interpolated just as in the other method. All plots whose heights lie in a given narrow band are assumed to have the same quality of site. This method is

based on the principle that the height of an even-aged stand is a reliable index of the quality of site. It has been proved by repeated experiment that the classification of sample plots by this method and by that just described in the preceding paragraph leads to practically the same result.

Sometimes the average height of the stand is used, but some authors advocate the determination of the quality of site by means of the maximum height. Still another plan is to judge the quality of site by the volume or height of a specified number of the largest trees instead of by the total volume or the height of the stand. Thus one might use the volume or height of the 200 or 300 largest trees on each plot. The purpose of this plan is to eliminate all possible errors arising from differences in thinning, that is, from the presence of more or less small suppressed trees. Still another plan sometimes suggested is to base the quality of site not on the largest trees but on the second 100 trees, in order to eliminate errors due to the presence of abnormally large trees, such as occur in most stands which have been established by natural reproduction.

The plots which are of the same quality of site are then grouped together and average curves constructed for volume, height, diameter, basal area, number of trees, and so on, and the results tabulated as a part of the yield table.

192. Normal Yield Tables in this Country.—Some maintain that it is not feasible to construct normal yield tables in this country, because of the irregularity of our even-aged stands, most of which have originated from natural reproduction and are generally composed of a number of species in mixture. This claim is due to a false idea of what constitutes a normal stand. It is entirely possible to make tables of the yield of fully stocked stands which have started under a specified set of conditions and have been managed in a specified way. Such tables show the maximum yield under certain conditions and serve as an index or standard of comparison. They are, therefore, true index or normal yield tables, although their results are not so high

as the European tables. In other words, the standard of the highest average yield actually obtainable in many of our forests is not so high as that in Europe, because the systems of management are not so intensive.

There are three problems of yield tables for even-aged forests in this country: 1. Yield tables for unthinned pure stands. 2. Yield tables for unthinned mixed stands. 3. Yield tables for thinned stands.

193. Normal Yield Tables for Unthinned Pure Stands.—

These tables are required now in many sections of the country where clearings made by fire, cuttings, wind, or otherwise, come up to pure stands approximately even-aged, and where it is impractical to make improvement thinnings at present and probably not for a considerable length of time.

The method of constructing the tables is, in general, to take a large number of plot surveys in pure, fully stocked stands of different ages occurring in different situations, and average them together as explained for the European forests. The chief difficulty in this country is to find plots which are pure and fully stocked. If none exist, then it is unnecessary to make yield tables for pure forests, but tables for mixed forests are made instead. With many species such plots do occur and in sufficient amounts to make tables which will meet the requirements of our present problems. It is often difficult to find whole acres which are in every way satisfactory. In this case irregular plots, if necessary less than one acre in size, may be taken. The adjustable staff-head, adjustable angle-mirror, or staff-compass may be used to lay out irregular plots, which give satisfactory results provided the angles are not acute.

The plots should be pure and fully stocked. It is an unsatisfactory method to use plots which are not pure or fully stocked, and by estimating the degree of density convert the measurements into terms of full stocking. This was done by the author in an investigation of the white pine, with results which have proved unsatisfactory.

The trees on the plots are carefully calipered in the ordinary way and then test trees cut to enable the accurate determination of volume. One of the diameter group methods, like the arbitrary group or volume curve method, should be used, and 6 to 10 test trees used for each plot, except in the young stands, where 3 to 5 test trees ordinarily suffice. If it is impractical to take test trees on account of the necessity of buying the trees or for other reasons, volume tables are used. The test-tree method is, however, to be used when possible.

In many investigations it is desirable to keep separate the main stand and the trees which ought to be removed by thinning. This necessitates marking for an improvement thinning before the calipering is done. The diameters of the marked trees are recorded in a separate column and test trees cut to enable a separate computation of volume. The yield tables will then show how much would be obtained if thinnings were made and enable the owner to judge of their practicability.

The yield tables should show for the whole stand (or in some instances for the main and subordinate stands separately) the number of trees per acre, the basal area, average minimum and maximum diameters, the average height, the total cubic volume, the merchantable volume in board feet or cords or both. Other information, such as the forest form factor, growth percent, etc., may be added if needed by the investigation in question.

194. Yield Tables for Thinned Stands.—The method described above cannot be used for stands which are thinned, because by proper thinning much larger trees can be produced in a given time, and the total merchantable timber will be considerably greater. By thinning, the period from the establishment of a stand to merchantable size can be often reduced by 10 to 20 years. In this country there are practically no stands which have been thinned from youth to maturity, so that the estimate of yield must be made by a different method from that described in the previous section.

As explained in section 153, it is fair to assume that by thin-

nings the growth of the trees may be so much increased that all will be as large as the average maximum obtained in an unthinned stand. That is, if a stand is fully stocked at the beginning, the forester can, by thinnings, govern the development of the crowns of the leading trees and produce timber of such a size as he desires up to the maximum capacity of the species, as represented by those standing in the open with entirely free crowns. The development which the forester usually desires is that of the maximum trees in an unthinned stand, for these represent rapid growth combined with good quality. This is particularly true in this country, where the stands are seldom so overcrowded as to make the maximum trees too small for use in this method.

2 The forester studies the diameter and volume growth of the maximum trees in stands of different ages, and studies the development of crown, in length and width, necessary to produce such trees. He first determines the size of trees which can be produced at maturity. Suppose, for example, that this size is at 60 years 15 inches at breast-height, 70 feet high, 19 cubic feet in volume, with a crown 30 feet long and 20 feet wide. The growth of the trees on which these data are based show the dimensions at previous periods. These dimensions are compared with those of maximum trees in younger stands, and the probable dimensions of the crowns at different ages, which are necessary for the production of the trees 15 inches in diameter in 60 years, are determined.

The next step is to determine how many trees can stand on an acre at different ages. This cannot be done merely by squaring the diameter of the crown, as, for example, 20 feet, and dividing the area of an acre by the result, for it may happen that a greater amount of space is required for the development of a crown of the size in question, or that the crowns may interlace to some extent and fit together more compactly than would be represented by this method. A silvical study is necessary to determine how close together trees may stand at different ages to produce crowns of certain sizes. Direct observation and

measurements of small groups of trees will answer this question. The required average crown space is determined for all ages and not merely at maturity, so that the number of trees and volume per acre may be shown from decade to decade up to the merchantable period. Such a table shows the yield of the leading trees, it being assumed that the subordinate ones are removed by the thinnings. The tables are not so complete as the regular normal yield tables. But they furnish the important information required in our present problems, and will serve until there are forests which have been under treatment long enough to be used as a basis for the tables.

The product of thinnings and their cost and returns must be estimated. The cost of the first thinnings can be definitely determined by sample plots. The later thinnings would, usually at least, pay for themselves, and may often be disregarded for the sake of conservatism. The study furnishes, in any case, sufficient information to make a conservative estimate of the returns in thinnings.

Inasmuch as the tables show the crown development and space required for the leading trees at different ages, they serve as an aid in making the thinnings, for the forester can see that as soon as the required crown space is reduced by the closing together of the branches and the necessary length of crown is falling off, by too heavy shade, a thinning is needed.

In making such a yield table, it must be borne in mind that too heavy thinnings may be injurious by drying out the roots or allowing the ground to run wild with forest weeds. The present method, however, is based on the maximum trees of a forest, and therefore represents a condition which does not require excessive thinnings.

This method may be used also to determine the yield of mixed stands which are thinned. It is more difficult to determine the number of trees per acre than in pure stands. The mutual effect of the mixture must be studied, a delicate silvical question, but one which may be worked out by a skilled investigator.

One problem is met that is not answered by any of the yield tables described above, namely, What will be the yield of stands thinned in middle or late life? The previous methods assume that thinnings are begun in early youth and are repeated at proper intervals. Thinnings are just being introduced into this country, and many unthinned stands 40, 50, 60 years and over, occur for which thinnings are advocated and a knowledge of whose future yield is desired. In the absence of available stands of this kind which have been thinned, the following plan is recommended: A study of volume growth of individual trees is made in stands which are thinned, as described for diameter growth in section 155. Thus the volume growth is determined for stands which are thinned for the first time at 30, 40, 50 years, etc. This growth is expressed as a percentage and is compared with that in stands unthinned, the difference representing percentage of increase in growth. Assuming that thinnings will be made later, sufficient to maintain the growth, the yield tables for unthinned stands may be corrected in the following way: Suppose that by thinning, the current rate of growth of a 30-year-old stand is increased 20 percent, the volume curve for the yield tables of the species and quality of site in question is at the 30-year point raised to show an increase in volume of 20 percent. A curve is then drawn from this new point parallel to the old curve and a new set of values introduced into the yield table. This same thing is done for stands thinned for the first time in 40 years, 50 years, etc. It is probable that the successive thinnings will cause an increase in each case, which would really cause the new curves to diverge from the old. The present assumption is, however, conservative, and serves the immediate needs of investigation.

195. Normal Yield Tables for Mixed Forests.—As far as the author is informed, practically no studies have been made of the yield of mixed forests. A few local yield tables for mixed stands have been made in Europe, but most authors avoid mentioning the subject, or state that it is impractical to construct them.

Nevertheless, European foresters advocate the establishment of mixed stands for the reason, among others, that the yield is greater than in pure forests; and yet no information is available as to what may be expected from such mixed stands. This lack is due to the difficulty of constructing yield tables for mixed forests. One perplexing question is whether a mixed stand 30 years old had the same percentage of mixture when established, and whether the mixture can be maintained as now until maturity. Another difficulty is to find stands with a uniform percentage of the species in mixture. Other problems, such as the manner of mixture, whether by groups or singly, and how the data are to be arranged to be of practical value, add to the difficulties, and have probably prevented investigators from attempting to construct such yield tables. Therefore to estimate the yield of a mixed forest in Europe one has to use yield tables for pure forests, allowing the correct percentage for each species in mixture. But mixed forests often yield more than pure forests. One example is quoted of the growth of a mixed spruce and pine forest in Silesia which in 80 years had a mean annual growth 18 percent greater than pure spruce and 28 percent greater than pure pine, on the same class of soil. By using yield tables for pure forests, and supposing each species to constitute 50 percent, the mixture would be assumed to have a yield less than pure spruce, whereas really it would be greater.

It is probable that normal yield tables for mixed stands cannot be made so complete as those for pure stands. The information of practical importance can, however, be furnished. Although the author has had no opportunity to use the method proposed below, he believes that it can be employed in a practical way in this country. To simplify the description, a specified problem will be assumed. Suppose that it is desired to make a yield table for white pine mixed with oaks. This is a common forest type in eastern Massachusetts, and the yield at different periods is of practical importance to the forester. Yield tables would show first the product of white pine in this type

of forest when it forms 25%, 50%, and 75%, respectively, of the mixture. The ordinary yield table shows the product of pure stands. Then the table should show the product of the other ruling species of the type for certain percentages in the mixture, and finally the yield of the miscellaneous species taken together. The mode of procedure is as follows: A large number of sample plots are taken in the specified type, comprising a variety of ages from 20 years to maturity. If the same percentage of mixture occurs in more than one quality of site, separate tables are made for each site. To take white pine first, its volume in each plot is determined, and also the percentage in mixture based on the total volume of the main crop. Then all values are entered on cross-section paper whose abscissæ represent age and ordinates volume. As each volume is entered, the percentage of white pine in mixture is entered above the point. When all points are plotted, there will naturally be an immense number of different percentages represented. Points having the same percentages are joined together by light pencil lines as far as possible, to show the trend of the curves. Then, guided by these lines, a curve is drawn for the yield, when the percentage of white pine in mixture is 25%, 50%, and 75%.

The same operation is repeated for other ruling species and finally for the miscellaneous species taken together.

The form of the table would be as follows:

YIELD PER ACRE OF MIXED SPECIES.

Age.	White Pine.			Red Oak.			Black Oak.			Miscel. Species.		
	Percentage in Mixture.			Percentage in Mixture			Percentage in Mixture.			Percentage in Mixture.		
	25%	50%	75%	25%	50%	75%	25%	50%	75%	25%	50%	75%
	Yield in Board Feet.			Yield in Board Feet.			Yield in Board Feet.			Yield in Board Feet.		

2
1
Suppose one owns a stand of pine and oak 15 years old, what will the yield be in 30 years? Suppose, further, the percentage of mixture is estimated to be pine 50%, red oak 30%, miscellaneous trees 20%. The yield of pine is taken directly from the table; the yield of red oak is taken by proportion as one-fifth the difference between the yields from 25% and 50%. So also the yield for the miscellaneous trees may be obtained by proportion.

196. Yield Tables for Many-aged Stands. — These tables show the future yield of many-aged stands at different periods after a portion of the trees have been cut under a specified method of selection. The tables under consideration contain the merchantable yield per acre of a given species before the selection cuttings and the predicted future yield in 10, 20, and 30 years after cutting. Other information may also be given, such as the number of trees per acre, the number of years required to obtain the original yield, and the mean annual increment. The tables are based on the assumption that the timber will be cut to a specified diameter limit. This does not mean that the method is applicable only where a rigid diameter limit is used in the selection cuttings. On the other hand, in using the selection system it is often necessary to leave some large trees for seed and to remove some which have not reached maturity. It is, however, generally customary, at least in this country, to use a certain diameter limit as a guide in making the selection cuttings, leaving where necessary trees above the limit and cutting certain others below that size, the amount of timber above and below the limit being about equal. Therefore, in speaking of cutting to a certain diameter limit, one means an *average* limit, and does not mean that the selection cuttings are made by rule of thumb and without reference to the silvical requirements of the forest.

The form and contents of yield tables for many-aged stands are illustrated in the Appendix.

The uses of yield tables for many-aged stands are as follows:

1. They enable the prediction of the growth of the trees left after lumbering, and the yield in merchantable timber in the future.

2. They enable the valuation of cut-over lands, and of immature timber which has been destroyed by fire.

3. They are used to determine the diameter limit which will in the long run be most profitable in lumbering.

4. They enable an owner to determine whether it will pay to hold his land for a second cut and whether he has sufficient land to supply his mills indefinitely with timber.

5. They replace the ordinary yield tables, described in sections 182 to 191, in all work of forest management in many-aged forests.

197. Necessary Field Work.—Yield tables for many-aged stands are based on three separate lines of field work, namely, valuation surveys, preparation of volume tables, and a study of diameter growth.

The valuation surveys are taken to determine the average number of trees per acre of different sizes which will be cut and the number which will be left standing to accumulate growth for a succeeding crop. The tables, so far made in this country, have been based on strip surveys which were also used in estimating merchantable timber, in making forest maps, etc. In these surveys it is customary to caliper the trees down to about three inches and on an occasional acre to count the saplings and seedlings. In calipering the trees, only those are included which are either of merchantable character or likely to be merchantable later on. Small trees must be scrutinized carefully, and if they are unsound, crippled, or otherwise obviously defective and unlikely to live until the next cutting, they are discarded or recorded in a separate column. All of the small trees now standing will, however, not live until the next cut even if perfectly sound and thrifty, because many will be killed in the struggle for light and space, just as in an even-aged stand, and many will be destroyed in felling and removing the larger trees.

The valuation surveys are taken under the assumption that all the sound thrifty trees below the given diameter limit will later become merchantable, while the loss through shading and through lumbering is determined in a separate study.

2 The following method may be used to determine the loss to young trees through lumbering: Plot surveys are taken in different forest types, so located and in such numbers as to give a good average of the prevailing conditions. The trees are calipered and those which will probably be destroyed in lumbering are recorded separately. One who has a knowledge of logging can determine what trees will be cut, how they will be felled and how hauled out; and he can determine just what small trees will probably be destroyed in this operation.

It is sometimes possible to determine on the ground what trees will probably die through shading. More often this loss must be estimated from a silvical study of the tolerance of the species with special reference to the new conditions of light after lumbering. This is usually a matter of judgment and observation rather than of actual measurement.*

The death of small trees through various causes is best expressed as a percentage of the number of trees of different sizes. Thus the reduction of the trees 4 to 6 inches in diameter might be estimated at 15%, 7 to 8 inches 10%, and 9 to 11 inches 5%. The loss due to shading would naturally be greater in thirty years than in shorter periods, a fact which must be taken into consideration. In all cases the loss should be made large enough to include the destruction of small trees for making skids, roads, bridges, and for other lumbering purposes.

* Some have recommended the calculation of the reduction in the number of trees with increase of age by the use of valuation surveys. It may be seen from the valuation surveys that the number of trees in the diameter classes falls off with increase of size. Suppose, for example, that there are on an average fourteen trees 8 inches and twelve trees 9 inches in diameter, and that it takes ten years to grow 1 inch in diameter. The loss, by shading, would then be 14.3% in ten years. The assumption is, however, not fair because new and more favorable conditions are established after lumbering.

A careful forest description accompanies all valuation surveys. Special attention must be given in these descriptions to the probable silvical effect of cutting to different diameter limits, to reproduction, and to the question whether it is necessary to leave seed trees above the diameter limit or to remove any below it. This information is of value in deciding on the diameter limit.

Further field work consists in a local study of growth of trees of different diameters. The method of making this study is fully described in section 159 and need not be further discussed at this point.

Local volume tables, for trees of different diameters, are also made, the data being usually collected at the same time as the measurements of growth.

198. Construction of Yield Tables.—The first steps in the preparation of the yield tables is to construct, for each forest type, a table giving the average number of trees of different diameters on the valuation areas. This table is sometimes called the model acre, for it represents an average of all the acres surveyed in a given type. Naturally the average number of trees of a given diameter may be a fraction, as shown in the table on page 339. The model acre enables the computation of the volume of the merchantable trees above any desired average diameter limit, by the use of volume tables.

The next step is to determine the future yield of the trees left after lumbering. The model acre shows the number of trees now standing below the diameter limit. This portion of the model acre is corrected to show the number of trees which probably will be standing at the time of the second cut. This is done by using the reducing factors for loss in lumbering and death by shade, determined as shown in the preceding section.

The table of growth of trees of different diameters is then used to determine the size of the trees in 10, 20, and 30 years after the cutting. In using the growth table it is assumed that a tree of a specified diameter will grow at the rate shown in the growth table for that diameter until it becomes one inch larger,

and that it will then grow at the rate shown in the table for that larger size. Thus a tree now 11 inches in diameter will grow at the rate of an 11-inch tree until it becomes a 12-inch tree, when it will grow at the rate given for that diameter in the growth table.

Another assumption is made, that as soon as a tree of a specified diameter, say 11 inches, has grown 1 inch it will have the volume shown for a 12-inch tree in the local volume table. Suppose it takes five years for an 11-inch tree to grow an inch, at the end of five years it has grown to have a volume equal to the average of the 12-inch trees now standing in the forest. The volume growth for five years is assumed to be the same as the difference in volume of an 11- and a 12-inch tree in the volume table. This is an assumption that has never been verified. A better method would be to use a table of volume growth of trees of different diameters instead of a table of diameter growth.

With the above principles in mind a table is made showing the condition of the stand now, in 10 years, 20 years, and 30 years after lumbering. An illustration of such a table is shown on the next page. From it the yield table in its final form may readily be constructed.

In this computation an allowance has been made for death during and after the first cutting, of 5% in 10 years, 7% in 20 years, and 10% in 30 years. The original cut of 1979.5 board feet could be obtained in 28 years. To obtain this result, subtract 1289.1 from 2143.2, divide by 10 to determine the mean annual growth between 20 and 30 years after cutting, then add enough years' growth to approximately equal 1979.5. Fractions of feet would be dropped in the final table.

In our illustration the computation has been made for a 12-inch-diameter limit. Most yield tables show the yield for other diameter limits to enable the determination of the method of cutting which in the long run will be most profitable.

199. Indian Yield Tables for Many-aged Stands. — The foresters in British India use a method similar to that just described,

COMPUTATION OF THE YIELD, PER ACRE, OF SPRUCE.
CUTTING TO A DIAMETER LIMIT OF 12 INCHES.
[Based on 223 Valuation Surveys.]

Present Condition.				Condition in 10 Years.				Condition in 20 Years.				Condition in 30 Years.				
Diameter, Inches.	Number of Trees.	Vol. Av. of Vol. Table, Bd. Ft.	Total Volume, Board Feet.	Annual Growth in Diameter, Inches.	Diameter, Inches.	Number of Trees.	Volume Aver. Tree, Board Feet.	Total Volume, Board Feet.	Diameter, Inches.	Number of Trees.	Volume Aver. Tree, Board Feet.	Total Volume, Board Feet.	Diameter, Inches.	Number of Trees.	Volume Aver. Tree, Board Feet.	Total Volume, Board Feet.
4	18.1															
5	13.0			0.09												
6	10.6			0.10												
7	8.3			0.109												
8	7.4			0.125												
9	5.4			0.140												
10	5.3			0.150												
11	3.8			0.160												
12	3.6	81	291.6	0.170	12.51	3.6	94	338.4	12.2	3.7	81	299.7	12.2	3.7	81	299.7
13	2.6	94	244.4	0.178												
14	1.9	121	229.9	0.185												
15	1.5	138	207.0	0.192												
16	1.2	173	207.6	0.20												
17	0.9	193	173.7													
18	0.6	238	142.8													
19	0.4	266	106.4													
20	0.3	294	88.2													
21	0.2	357	71.4													
22	0.2	390	78.0													
23	0.1	425	42.5													
24	0.1	460	46.0													
25	0.1	500	50.0													
Total	85.6		1979.5					338.4				1289.1				2113.2

to predict the future yield of many-aged stands of teak, sal, and other species cut under the selection system. These studies of yield are made in connection with the preparation of working plans for specified working areas, and the resulting tables of yield are applicable only to the tracts studied. Valuation surveys, in the form of strips, are taken to determine the number of trees of different sizes. The trees on the valuation areas are calipered and recorded in broad diameter or circumference classes. Thus Class I may include all trees over two feet in diameter, Class II trees 18 inches to 2 feet, Class III trees 12 to 18 inches, Class IV trees 6 to 12 inches, and Class V those below 6 inches in diameter. The forests are so irregular that 20-30% of the area must often be covered by the surveys, and some maintain that, in order to obtain satisfactory data for the prediction of future yield, this should be extended to 50% in sal and similar forests.

The valuation surveys are used to construct tables showing number of trees, by classes, standing on the tract in question. The following table, taken from a working plan for the Pozaundaung Reserve in Burmah, illustrates the procedure.

ESTIMATED NUMBER OF TEAK STANDING, IN 1901, ON THE
TOTAL AREA OF 51,728 ACRES.

Class I. Above 7 Feet in Circumference.	Class II. 6 to 7 Feet in Circumference.	Class III. 4½ to 6 Feet in Circumference.
13,100	9,300	21,068

The allowance of loss by death is, for Class I 5%, Class II 15%, Class III 30%.

A study of growth of the species in question is made to determine how long it takes for the trees to grow from one diameter class to the next higher. In the Pozaundaung working plan above referred to, the growth was based on the measurement of rings on 121 stumps, and the results arranged in the following table:

NUMBER OF YEARS REQUIRED TO PASS FROM A GIRTH OF:

0 to 3 Feet.	3 to 4½ Feet.	4½ to 6 Feet.	6 to 7 Feet.	Number of Years to Reach Maturity.
64.5	53.7	42.7	32	193

The annual production of the forest is represented by the average number of trees which reach merchantable size each year. Thus in the above example the minimum circumference limit is 7 feet. The growth table shows that 32 years are required for the second-class trees to become first-class, that is, in 32 years all the second-class trees will be 7 feet or over in circumference. The annual production may then be considered 9300, less 15%, divided by 32, or 247 trees. The method of using these data to determine the number of trees which should be cut annually is described in D'Arcy's Preparation of Working Plans. The discussion of that problem belongs to forest management and is beyond the scope of this book.

200 Empirical Yield Tables.—This term has been adopted by the author to designate tables showing the yield per acre, at different ages, of even-aged stands having an *average degree of stocking*, in contrast to normal yield tables, which represent fully stocked stands. The expression "empirical" has been chosen because the tables are based on the average yield actually found on areas of considerable extent. The tables are useful in many investigations in even-aged or approximately even-aged stands where it is not feasible or not necessary to construct normal yield tables. Such tables necessarily have only a temporary value, for, as the forests improve or deteriorate, the yield will later on be different from that now found on the areas under consideration.

Empirical yield tables are used to determine the value of second growth, to predict future yield, and to serve as a guide and check in estimating standing timber. If they truly represent the average degree of stocking of a given tract or region, they are

of greater use in the work just mentioned than normal yield tables, as their values may be used directly without discount. If, however, a forest is more or less fully stocked than the average shown in the yield tables, it is not so easy to make the proper corrections as is the case with the normal tables.

Empirical yield tables will doubtless be constructed in connection with working plans for areas which are managed under one of the methods of clear cutting. In many cases the tables will have to be made for mixed stands. Where fuel alone is the product, all species could be lumped together with no further separation than an indication of the percentage of hard and soft wood, body-wood and limb-wood, etc. Such a table would enable the prediction of the future value of the crop. If logs, ties, etc., were to form a part of the crop, the results could still be expressed in cords, but there should also be shown the percentage of timber suitable for logs, poles, ties, or other products. In predicting future values a different price per cord would be used for the different products.

The work of constructing empirical yield tables is similar to that required for normal yield tables, the chief difference being in the selection of the sample plots and in the grouping and classifying the plots in the office. In general the following method may be used to construct the tables:

A series of plot surveys is made in the different forest types. The plots are distributed in each type so as to include different age classes up to the maximum required in the investigation. The plots are located so as to represent average conditions, with respect to density of stocking, development of trees, etc. Each survey comprises calipering of the trees, measurement of test trees for the computation of volume, and a detailed forest description. The first work in the office is to separate the surveys into groups according to the forest types they represent, the assignment of a survey to a given type being based on the forest description. The next step is to determine the volume and average age of each stand. A table is then constructed showing the average volume of stands of different ages. This is done by

means of a volume curve based on age. The volume of each survey is plotted on cross-section paper whose horizontal lines represent age, and vertical lines volume. An average curve is then drawn through the points and the values for every ten years are read off and tabulated. Sometimes the volumes of stands of the same age vary so widely that it is difficult to draw an average curve. If the variation is too great, a satisfactory table cannot be made. Usually the forester can judge in the field whether the conditions in a single forest type are uniform enough to construct a useful empirical yield table.

If the volumes of the different surveys differ very widely, a table may often be constructed by using the mean annual increment. The table shown below was constructed in this way. There were not enough surveys to construct volume curves in the ordinary manner. Therefore the mean annual growth in volume was determined for each survey and the average obtained for all stands 10 to 20, 20 to 30, 30 to 40 years old, etc. An average table showing the mean annual growth in volume was constructed, irregularities being evened off by interpolation. The total yield in cords was then computed by multiplication. The following table was constructed by this method, for use in a working plan for 12000 acres in southern New York.

EMPIRICAL YIELD TABLE FOR DIFFERENT FOREST TYPES ON
A TRACT OF 12,000 ACRES IN SOUTHERN NEW YORK.

[Based on 167 Plot Surveys.]

Age, Years.	Mixed Hardwood Type, Quality I.		Mixed Hardwood Type, Quality II.		Mixed Hardwood Type, Quality III.		Chestnut Type Quality I.	
	Yield per Acre, Cords.	Mean Annual Growth per Acre, Cords.	Yield per Acre, Cords.	Mean Annual Growth per Acre, Cords.	Yield per Acre, Cords.	Mean Annual Growth per Acre, Cords.	Yield per Acre, Cords.	Mean Annual Growth per Acre, Cords.
10 to 20	8.7	0.58	4.2	0.28	10.6	0.71
20 to 30	20.0	0.80	11.5	0.46	7.0	0.28	25.0	1.00
30 to 40	25.9	0.74	17.8	0.51	12.9	0.37	36.7	1.05
40 to 50	29.3	0.65	17.1	0.38	11.7	0.26	40.5	0.90
50 to 60	30.8	0.56	17.0	0.31	11.0	0.20	40.7	0.74
60 to 70	30.5	0.47	16.9	0.26	10.4	0.16	38.3	0.59

201. Periodic Measurement of Permanent Sample Trees and Plots.—There are a large number of problems in forest mensuration which cannot be satisfactorily solved by the methods described in the previous page, but which require repeated measurements and observation of specified trees or stands. The yield tables in Europe are now based in part, and will eventually be based almost entirely, on repeated measurements of permanent sample plots. The German government has established a very large number of plots throughout the State forests which are visited annually or every few years, and the necessary observations and measurements are taken for the study of the development of the stands. The method is briefly as follows: Stands are chosen which are fully stocked, and ordinarily only those which are composed of a single species. The plots are not smaller than a quarter hectare each. Permanent posts are set at the corners and the boundary-lines are marked by shallow ditches or by painting the boundary trees. Surrounding each plot is a so-called "isolation-strip," 50 to 100 feet wide, which is under the same treatment as the plot. Before calipering the trees a uniform thinning is made on the plot and isolation-strip. The trees are then calipered, and are usually numbered so that the diameter of each tree at the present time may be compared with that found later on. After calipering, the volume of the stand is computed by the use of the Urich or a similar method. The test trees are cut from the isolation-strip and not from the plot. After from 3 to 5 years the trees are again calipered and the volume determined as at first. When three to five periodic measurements covering 15 to 20 years have been taken on each plot, the construction of yield tables becomes much simpler and the results are much more reliable than when they are based on one measurement of each plot.

The study of permanent sample plots was begun in Germany in 1860 and since then enough time has elapsed to enable the construction of accurate yield tables for a number of species.

202. Permanent Sample Plots in this Country.—At the present time in this country foresters are handicapped by the lack of results derived from experience. Many of our operations in silviculture are based on the judgment of the forester as to what *probably* will happen, rather than on what has been *known* to occur in some specific instances. In order to secure definite data of the results of different kinds of treatment in different types of forest, the United States Government is now establishing a large number of sample plots for repeated observation.* The purpose of these plots is not only to study the rate of growth of individual trees and of whole stands after cutting, but also to study the reproduction of various species under different conditions, their tolerance in youth, and other silvical characteristics. In general the following class of plots have so far been established:

1. Plots of one-half acre or more in even-aged stands, established to determine the results of different degrees of thinning. These plots are similar to those established in Europe. Permanent stakes are set at the corners, the boundaries permanently designated, and the trees numbered. The numbering is first done with chalk when the trees are calipered, and later the permanent numbers are put on in paint. Each tree is calipered two ways and a small paint spot is made at the point where the beam of the caliper touches the tree. This enables the forester to caliper the tree at exactly the same place when measurements are taken in later years. The diameters are recorded in the form shown below, and when a tree is recorded the caliper man gives also the estimate of the height and tree-class. A very careful description is made of each plot which is indicated on a map in order that it may later on be readily located. The records thus show the condition of each tree. A later measurement in 3 to 5 years will show the increase in diameter of each tree, its estimated height, and whether or not it belongs to the same class as previously. The results of different degrees of thinnings may be determined

* This work was organized for the Government in 1904 by Mr. G. H. Myers and the author.

by such plots in a way that would be impossible with the ordinary means of observation.

Experiment No..... Tallied by.....
 Location..... Measured by.....

 Date.....

Tree No.	Species.	Diameter, Breast-high.	Class.	Height.

2. Plots of one acre in many-aged stands, to test the effect of the removal of the old trees on those left standing. In many-aged forests, like those in the spruce region of the northeast, there is a lack of definite information as to how the small trees will develop after the older ones have been removed under different methods of selection. Sample plots of one acre each are laid off in selected places, and enough are established to include the different local problems of silviculture. In addition to the records of diameter, height, tree-class, and the forest description described in the previous paragraphs, an accurate map is made locating each tree. This is done in the following way: A traverse board is set up in the middle of the plot, and the location of each tree is determined by means of a small alidade and by measuring the distance with a tape. The number of each is also entered on the map. A horizontal sketch representing the projection of the crown is made in the case of the trees whose development is to be specially observed.

3. Reproduction plots of about a square rod each, to study the natural reproduction and the development of the young trees under given conditions. These small plots are laid out in great number where reproduction cuttings are to be made or have been made. Permanent posts are set at the corners and then all

growth on the plot is counted. Seedlings and other small growth are recorded in the form shown below. A sketch is prepared showing the projection of crowns of all trees, above the seedling stage, which shade the plot. A careful forest description is made as in the previous cases.

Experiment No. Talled by

Date. Counted by

Location.

.....

Species.	0-3 In.	Age.	3-6 In.	Age.	6-12 In.	Age.	12-18 In.	Age.

Species.	18-24 In.	Age.	2-3 Ft.	Age.	3-4 Ft.	Age.	4-5 Ft.	Age.

4. Single-tree plots, comprising single trees or small groups of trees definitely located and numbered, for the observation of their behavior under specified conditions. There are many cases where American foresters are in doubt as to the exact effect on a given tree of the removal of one or more of its neighbors. The repeated observation and measurement of individual trees or groups of trees growing under certain conditions would answer many of these questions. Such trees are designated by one or several permanent posts and their location indicated on the map. The trees are numbered and the point of measurement marked as described for the other plots. Vertical and horizontal sketches are made of the trees under observation, as well as of the neighboring trees, which may influence their development.

Single-tree plots are required in the study of tropical trees whose growth cannot be determined by annual rings.

5. Description plots, comprising areas of different sizes chiefly located in the lumber woods, to observe the results of different kinds of lumbering. These areas are usually from 10 to 100 acres each. No measurements of trees are taken as in the preceding plots, but a very detailed description is made of the woods before and immediately after the lumbering. The areas are inspected every two or three years and the changes which occur on them are noted. On these plots there are usually located a considerable number of reproduction plots.

CHAPTER XVIII.

GRAPHIC METHODS USED IN FOREST MENSURATION.

203. The Use of Graphic Methods.—The results of scientific work in forest mensuration are expressed in tables of averages, based on widely varying values. These tables are constructed by the use of the simplest statistical method, namely, graphic interpolation. This method consists in representing graphically on cross-section paper a series of variable values and correlating them by a curve.

The advantages of the graphic method of compiling statistics obtained in forest mensuration are as follows:

First, it presents clearly to the eye the proper relationship of the quantities concerned, showing results in a way that a set of numerical figures in tables only indicate by prolonged study or fail entirely to indicate.

Second, it offers a means of averaging data much more quickly than by ordinary mathematical calculations.

Third, the results are accurate, errors which might otherwise escape detection being visible to the eye. For the same reason it gives the best means of culling out data which may be abnormal.

Fourth, it is an excellent method of determining a general law of variation of quantities. In work of forest mensuration it is difficult to secure enough field data to arrive at the law of variation of values without some interpolation. It is usually the average values which are sought, rather than the actual values as obtained in the field. Suppose, for example, that a thousand trees are measured in the field to show the relation between

height and diameter in a specified forest. If these are grouped by diameters, and the average height of each group is determined arithmetically, the heights of different diameters will follow each other more or less irregularly in the table, which evidently is not true of the natural law sought after. But the results will approach nearer to this law and the irregularities be correspondingly less, the greater the number of trees measured. It is not feasible in practice to secure enough data to construct a perfectly regular table by merely averaging together the figures taken in the field, and there must be some interpolation to obtain the natural law of variation of heights with diameters. Therefore, the numerical averages are plotted on cross-section paper and the various values corollated by means of a regular curve. The points on this curve will approach nearer to the natural law than any of the original points plotted, except as far as the latter happen to be on the curve. Then the value of any point upon the curve is not based merely on the field measurements which it represents, but is dependent for its value upon all of the original data. If 1000 trees were measured in the field, each point on the curve depends for its value on 1000 trees; whereas each original point on the cross-section paper may have depended only on a few trees.

204. Plotting of Values on Cross-section Paper.—Cross-section paper, with its series of perpendicular lines, represents a system of rectangular co-ordinates. Any two lines perpendicular to each other, as two of the heavy lines on the paper, may be taken as co-ordinate axes. Any two other lines, parallel respectively to these axes and at known distances from them, will intersect in a point whose position is definitely fixed. The horizontal distance of this point from the vertical axis is called the abscissa of the point and the vertical distance from the horizontal axis is called the ordinate. A given value may be graphically represented as a point, if its ordinate and abscissa are known. Suppose, for example, that it is desired to represent on cross-section paper the height of a tree of a given diameter. Let the horizontal

lines or abscissæ represent diameters and the vertical lines or ordinates represent heights. Then one measures off on the horizontal axis a distance corresponding to the diameter, according to an arbitrary scale, and on the vertical axis, a distance corresponding to the height. The intersection of the perpendicular lines erected at these two points fixes the position of the point which represents the height in question. Suppose that a large number of trees have been measured and a regular table is required, showing the average heights of trees of different diameters. This may be made by plotting the heights on cross-section paper as just explained, and correlating the values by a curve. The measured trees are classified by diameters and the heights of trees of the same diameter averaged. The results are arranged in a table like the following:

AVERAGE HEIGHTS OF TREES OF DIFFERENT DIAMETERS.

Diameter Class. Inches.	Average Diameter of Trees Measured, Inches.	Average Height of Trees Measured, Feet.	Number of Trees Measur:d.	Average Height from Curve, Feet.
6	49.5
7	7	54.5	4	54.5
8	8.05	60	3	59.75
9	9	66.5	2	64.5
10	10.2	68	3	69
11	11	73	4	73
12	76.5
13	13	79.5	4	79.5
14	13.8	80	3	81.5
15	14.9	84	1	83.4

Examination of this table (column 3) shows that the heights increase with the diameters by irregular differences. If the heights are plotted on cross-section paper, these irregularities are very apparent. In plotting the points one lays off the diameters on the horizontal lines and the heights on the vertical lines, the scales being chosen arbitrarily. (Fig. 52.) In general the aim should be to choose such scales that the curve will be neither very flat nor very steep. This is accomplished if the largest

ordinate is not less than one-half or greater than one and one-half of the greatest abscissa. This arrangement of scales makes the construction of the curve easier and more accurate. In the illustration given above one large square subdivided into tenths is given the value of one inch on the abscissæ and ten feet on the ordinates. The basis of the table in our illustration is diameter. The diameters are, therefore, the independent variable quantities and the heights are dependent variable quantities. It is customary to lay off the independent quantities on the abscissæ, so in the present case the latter represent diameters. The points are marked by a sharp pencil or draughtsman's pin-point. Beside each point is indicated, in light pencil, the number of trees on which the value is based. This is given because in locating the curve the consideration given to a single point is in direct proportion to the number of trees on which its value is based.

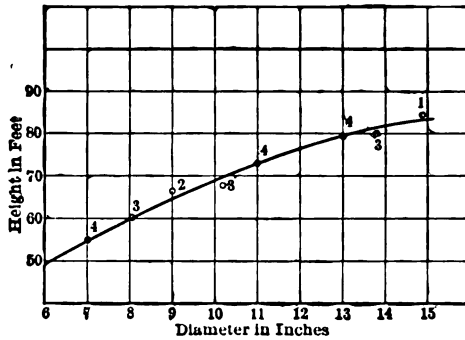

FIG. 52.--Curve showing Height of Trees of Different Diameters.

205. Construction of Curves.—After plotting the points, they are joined by straight lines in light pencil. This shows the trend of the curve and assists in its location. After careful inspection of the series of points, the curve is drawn free hand through the points, or as near them as possible. In locating the curve the weights of the various points are considered, and it is drawn through or nearest to those representing the largest number of

measurements. The curve must be regular and smooth as distinguished from wavy and broken.

The curve should be located by the eye and first drawn free hand. Then the irregularities of the free-hand curve may be smoothed off by a spline or similar device. The resulting curve represents the heights of trees of all diameters, in their proper relation to each other, and from it the height, corresponding to any diameter, may be determined. Thus, to find the height of a 6-inch tree, measure, to scale, the vertical distance from the 6-inch mark on the horizontal axis to the curve. The heights, corresponding to each inch diameter, may thus be determined and a table of averages constructed, as shown in column 5 in the table on page 351.

When the data are based on a large amount of field measurements, it is a simple matter to draw such a curve, for the values are so regular that a curve may readily be drawn through or near most of the points. But when the data are rather meagre, more interpolation is necessary, and the construction of the curve requires a high degree of skill.

In the illustration given above, the trees were grouped according to diameter, and the heights of all trees of a single-inch diameter class averaged together. Theoretically in this problem it would be possible also to work out a table of the variation of diameters based on height. In that case the trees would have been grouped by heights and the diameters of all trees of the same height averaged together. At first thought it would seem that two curves representing values worked in the two principles would coincide. They are, however, quite different. This will be clear from a graphic illustration, using height and age as the variables. Suppose, in Fig. 53, curves *A* and *B* represent the growth in diameter of two trees. In averaging the values of these curves, it makes a difference whether the average age of trees of different diameters or the average diameter of trees of different ages is sought. In the first case, ages are the dependent variables, and therefore are averaged together. Graphically, points on

the same abscissæ are averaged and curve *C* results. In the second case, diameter is the dependent variable and points on the same ordinates are averaged, giving curve (*D*) In finding the average of two curves, that is, to interpolate a curve exactly between them, one should not bisect the angle, but divide the vertical lines between the curves and draw the average curve through these dividing marks.

The explanation in the foregoing pages shows how to construct a table giving the relation between two series of variable quantities. In many problems, however, there are three variables. Thus, for example, in constructing a log rule, one has to deal with three variables, diameter, length, and volume. Suppose that 1000 logs have been sawed at a mill, and the diameter, length, and actual volume of each determined. The average contents of all logs having a common diameter and length are then determined and the results tabulated in a form like the following:

TABLE A.
AVERAGE CONTENTS OF LOGS.

Diameter Inches.	Length in Feet				
	8	10	12	14	16
Contents in Board Feet.					
8	16	18	23	27	34
9	19	24	33	36	44
10	24	26	43	48	56
11	30	36	53	57	66
12	38	45	67	70	81
13	47	55	76	86	94
14	56	64	96	102	118
15	67	80	114	124	135
16	67	92	126	140	159
17	93	110	146	160	184
18	106	122	164	188	215

The values in this table are then correlated by a series of harmonized curves. Separate curves are first made to correlate

the values in the vertical columns of the table. These curves may be best constructed on a single sheet of cross-section paper, for this enables a certain harmonizing of their forms. If a table (Table B) is constructed from these curves, the values in the

TABLE B.
AVERAGE CONTENTS OF LOGS.
(Vertical columns made regular by a series of curves.)

Diameter - Inches.	Length in Feet.				
	8	10	12	14	16
	Contents in Board Feet.				
8	16	18	23	27	34
9	19	23	33	36	44
10	24	29	43	47	55
11	30	36	55	58	67
12	38	45	67	71	81
13	47	55	80	86	97
14	57	66	94	102	115
15	68	79	110	120	135
16	80	92	127	140	159
17	93	107	146	162	186
18	106	122	166	188	215

vertical columns will be regular; but the table may be irregular when read across, that is, the volumes of logs of the same diameter will increase with length by irregular differences. Expressed in another way, the curves in Fig. 54 are all perfect in themselves, but they are not at proper distances apart. Therefore it is necessary to construct a second series of curves on another sheet of cross-section paper, showing the contents of logs of different lengths for given diameters. For this series of curves, the second and not the first table is used. Fig. 55 shows the manner of constructing such a series of curves. A table is then constructed from this second set of curves. This table will generally be found regular when read in any direction (Table C). If, however, there are still any irregularities, a third series of harmonized

curves may be constructed to even off any irregularities in the vertical columns caused in the construction of the second series. Such a table is more accurate for use in scaling a large number of logs than the original table representing the arithmetical average of the field measurements. The reason is, that individual variations and accidental features are thrown out and the values are all brought into proper relation to each other. Each value in the final table depends on every log measured, while in the first table each value depended only on the average of a few logs.

TABLE C.

AVERAGE CONTENTS OF LOGS.

(Obtained by evening off the horizontal lines in Table B by a series of curves.)

Diameter. Inches.	Length in Feet.				
	8	10	12	14	16
	Contents in Board Feet.				
8	16	19	22	27	32
9	19	25	31	37	43
10	24	32	40	47	55
11	30	40	50	58	67
12	38	50	62	72	81
13	47	61	74	86	97
14	57	72	88	102	115
15	68	86	103	120	135
16	80	100	120	140	159
17	93	115	138	162	186
18	106	133	160	188	215

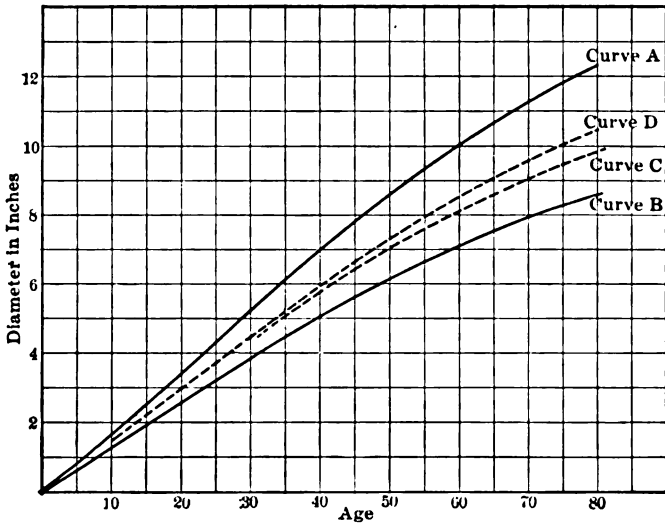

FIG. 53.—Method of Averaging Two Curves.

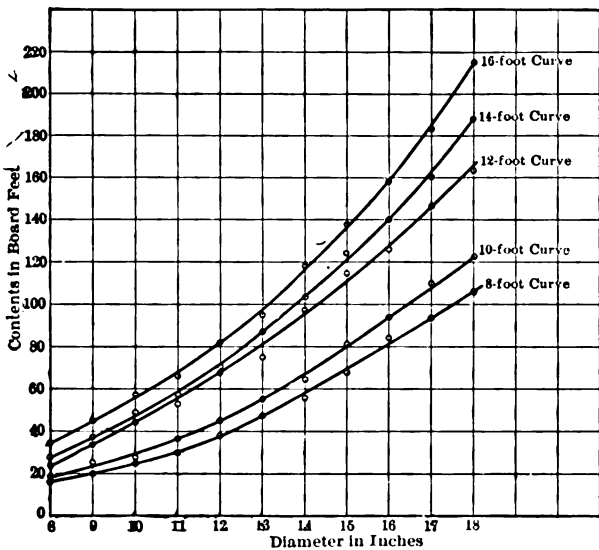

FIG. 54.—Series of Volume Curves of Logs of Different Lengths, Based on Diameter

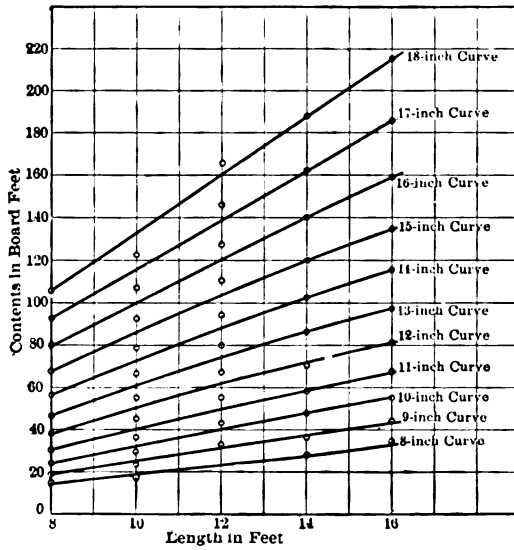

FIG. 55.—Series of Volume Curves of Logs of Different Diameters, Based on Length.

APPENDIX.

LEGISLATION REGARDING THE MEASUREMENT OF LOGS.*

THE laws discussed in the following pages are those of most interest and importance to the student of forest mensuration. There are included laws regarding log rules and also those relating to the appointment of official scalers and lumber or timber surveyors. The states are treated alphabetically, without regard to the importance of the legislation.

Arkansas. The most important statute in Arkansas, with regard to the measurement of timber, relates to the establishment of a standard log rule. It is of interest to note that the old Scribner rule, which was at first the statute rule, was replaced 1901 by the Doyle rule.

Revised Statutes, 1894. Chap. 85. Sec. 3876. The commissioner of state lands shall be ex officio state lumber inspector.

Act of May 23, 1901.

Sec. 1. That the Doyle stick or standard of log measurement be and the same is hereby declared to be the standard by which all sawlogs, bought sold, cut or hauled in this state shall be scaled or estimated.

Sec. 2. That any person using other than this stick shall be fined not less than \$50 nor more than \$200.

* This chapter was compiled by Mr. J. O. Hopwood.

California. The Spaulding log table was established as the statute log rule by the following law:

Act of 1878. Chap. 415. Sec. 1. There shall be but one standard for the measurement of logs throughout this state.

Sec. 2. The following table, known as Spaulding's Table for the Measurement of Logs, is hereby made the standard and table for the measurement of logs throughout this state, to wit: Table given in full.

Colorado. There is no statute log rule. The only law of special interest to foresters is that which delegates to towns and cities the power to regulate inspection and the measurement of timber.

Florida. Revised Statutes, 1892. Sec. 888. Chap. XIII. Doyle's Rule and Log Book for the Measurement of Saw Logs is the standard measurement for both round and square logs which are required to be scaled or measured within the limits of the state.

Inspectors of lumber and timber are appointed by the governor for each county. They are required on *summons* to measure and give report of quantity and quality of lumber to interested parties.

Georgia. The inspection of timber is provided for by the towns. No statute log rule has ever been adopted.

Iowa. The Board of Supervisors of each county appoints an inspector of lumber and shingles. There is no statute log rule.

Idaho. In the Session Laws of Idaho of March 6, 1903, it is provided that the State be divided into five districts. The governor appoints an inspector for each district, who shall reside within his district and holds office two years. The inspector scales logs and makes bills to persons interested and records these in his office; and he records log marks of individuals.

The law states that unless otherwise agreed upon the Scribner decimal rule shall be the standard rule for scaling or measuring logs in the said districts, but in all cases the bill of the inspector shall state by what rule the logs were scaled or measured.

Louisiana. The laws of Louisiana of interest to the student of log rules are the following:

Act 147, 1900, p. 231. Sec. 1. That what is known as the Doyle Rule, or scale, shall be the standard rule for the measurement of sawlogs in this state; provided that this act shall not prevent the use of a different rule or scale when both the seller and the buyer prefer to use a different scale.

Maine. The statutes of Maine which deal with the appointment and the duties of timber inspectors are of special interest. They are quoted in full, as follows:

Revised Statutes, 1883. Chap. 41. Sec. 1. Towns may by ordinance regulate the measure and scale of wood, coal, and bark therein, and the location of teams hauling the same; and may enforce it by reasonable penalties. All cord-wood exposed for sale shall be four feet long, including half the scarf, and well and closely laid together; a cord of wood or bark shall measure eight feet in length, four feet in width, and four feet in height, or otherwise contain one hundred and twenty-eight cubic feet, and the measurer shall make the allowance for refuse or defective wood and bad stowage.

Sec. 14. Every town, at its annual meeting, shall elect one or more surveyors of boards, plank, timber, and joist; one or more surveyors of shingles, clapboards, staves, and hoops; and every town containing a port of delivery whence staves and hoops are usually exported, shall also elect two or more viewers and cullers of staves and hoops; and the municipal officers of a town may, if they deem it necessary, appoint not exceeding seven surveyors of logs; and all said officers shall be sworn.

Sec. 25. Surveyors of logs may inspect, survey, and measure all mill logs floated or brought to market or offered for sale in their towns, and divide them into several classes, corresponding to the different quality of boards and other sawed lumber which may be manufactured from them; and they shall give certificates under their hands of the quality and quantity thereof to the person at whose request they are surveyed.

Massachusetts. The statutes delegate to the governor the power to appoint, with consent of council, a surveyor-general whose duties are to survey lumber. Hewn timber and round timber used for masts and ship-building are surveyed and sold as ton timber at the rate of forty cubic feet to the ton. There is no statute log rule.

Minnesota. The Scribner Rule is the official log rule of Minnesota. The following quotations from the statutes contain the most important points regarding the official scale and also the appointment of timber scalers.

Revised Statutes, 1891. Sec. 2245. There are established seven districts for the survey and measurement of logs and lumber within this state.

Sec. 2247. Surveyors appointed biennially by the governor with advice and consent of the senate—a surveyor-general for each of the districts aforesaid, who shall hold office for two years.

Sec. 2254. It shall be the duty of the surveyor-general of the first district to scale or cause to be scaled all rafts, brills, or lots of logs which may pass down or through Lake St. Croix, before passing out of the said Lake St. Croix; also all rafts, brills, or lots of logs run through or gathered into any side towns or lake towns for sawing or other use within the limits of the said district, subsequent to the scale at the St. Croix Boom Corporation boom. All logs thus scaled shall be entered on the surveyor's books in their proper place.

Sec. 2257. Scale rule for survey of logs. The surveyor-general shall keep posted in his office a written rule or scale of logs of all sizes and lengths, which shall govern him in his surveys, and the scale rule known as Scribner's rule is hereby adopted as the only legal rule for the survey of logs in this State; provided that every log shall be surveyed by the largest number of even feet which it contains in length over ten feet and under twenty-four feet, and all logs of twenty-four feet in length or more shall be surveyed as two logs or more.

New Hampshire. The statutes of New Hampshire relating

to the measurement of timber are especially complete and definite. They are given in full, as follows:

Revised Statutes, Jan. 1, 1901. Chap. 128. Sec. 1. Surveyors of lumber shall survey all plank, boards, spars, slit work, shingles, clapboards, and timber previous to the sale thereof, and shall measure the same if necessary, having due consideration for drying and shrinking, making reasonable allowance for rot, knots, and splits. They shall mark the same anew according to the just content thereof, if requested by the seller or purchaser, and give a certificate of the quantity and sorts, if required, on payment therefor.

Sec. 3. The standard of thickness of merchantable plank shall be two inches, and when any plank of a different thickness shall be purchased, it shall be admeasured and calculated by that standard.

Sec. 4. All round ship timber shall be measured according to the following rule: A stick of timber sixteen inches in diameter and twelve inches in length shall constitute one cubic foot, and in the same ratio for any other size and quantity, forty feet shall constitute one ton.

Sec. 5. All round timber the quantity of which is estimated by the thousand shall be measured according to the following rule: A stick sixteen inches in diameter and twelve inches in length shall constitute one cubic foot, and the same ratio shall apply to any other size and quantity. Each cubic foot shall constitute ten feet of a thousand.

Sec. 6. Any person measuring round timber the quantity of which is estimated by the thousand shall mark upon each log surveyed by him the contents thereof, unless it is otherwise agreed by the parties contracting.

North Carolina. There is no law prescribing a log scale. Commissioners of counties appoint an inspector for each of the towns to measure lumber by board measure, but no special rule is prescribed.

Oregon. There are no statutes regarding log measurement except in Coos County, where Scribner's is the statute rule.

Laws of 1887. Sec. 4220. There is hereby created the office of surveyor of lumber in the log for the county of Coos in said state.

Sec. 4222. It shall be the duty of the said surveyor or his deputy to ascertain by actual survey and measurement the quantity of lumber contained in each and every sawlog, boom, or raft of logs or timber to be sawed or manufactured into lumber.

Sec. 4223. For the purpose of ascertaining the quantity of lumber in any log, boom, and raft of logs that he may be called upon to measure or survey, he shall use the scale of measurement known and designated as Scribner's scale, or such other standard scale as may be in general use in his county by dealers in logs. He gives certificates of measurement and keeps the same registered in his office.

Rhode Island. This state has a surveyor of lumber who is elected by the councils at Providence.

Vermont. The state rule is the so-called Vermont or Humphrey's rule. This rule is being abandoned by many lumbermen. An attempt is being made to substitute for it a new statute rule. The present law is as follows:

Revised Statutes, 1894. Sec. 4301. In all bargains for or sales of sawlogs or round timber by measure the number of feet, unless otherwise stipulated by the parties, shall be ascertained as follows: Multiply the average diameter of the top of the log, inside the bark, in inches, by half such diameter in inches, disregarding fractions of an inch less than one-half, and regarding fractions greater than one-half as a full inch, and the number obtained as a product will represent the contents in feet of a log of that diameter twelve feet long. If the log is less than twelve feet long, the actual contents will be the same fraction of the above product as the actual length of the log is of twelve feet. If the log is more than twelve feet long, commence at the upper end and measure it into sections of twelve feet; then find, according to the above rule, the contents of each section and fractional section. The aggregate of the contents of the sections will be the contents of the whole log.

Sec. 2980. At the annual meeting towns shall choose from among the inhabitants thereof the following town officers, who shall serve until the next annual meeting, and until others are chosen, unless otherwise provided for by law.

Sec. 3064. The inspector of lumber and shingles shall, at the request of any party interested, examine and classify the quality of lumber and shingles and measure lumber and give certificates thereof; and for such services shall receive reasonable compensation from the party requiring the same.

Washington. The laws of Washington relating to the measurement of logs are more complete than in most states. They are as follows:

Revised Statutes. Sec. 3103. That there shall be established within this state two districts for the survey and measurement of logs, and that counties of Whatcom, Skagis, San Juan, Island, Snohomish, King, Pierce, Mason, Lewis, Skamania, Clark, Cowlitz, Wahkiakum, Pacific, Chehalis, Thurston, Kitsap, Jefferson, and Challam shall constitute district number one, and that Seattle, Washington, shall be the principal place of business of district number one; and that the counties of Okanogan, Stevens, Spokane, Lincoln, Douglas, Kittitas, Yakima, Franklin, Adams, Whitman, Garfield, Asotin, Columbia, Walla Walla, and Klickitat shall constitute district number two, and that Spokane, Washington, shall be the principal place of business for district number two.

Sec. 3104. There shall be biennially appointed by the governor, with the advice and consent of the senate, a state log-scaler for each of the districts aforesaid, who shall . . . hold office for two years and until his successor is appointed. . . . Provided, that it shall be the duty of the state log-scaler . . . to make scale bills and record them in the books of the log-scaler's office. . . . Each of the said log-scalers shall have a seal of office.

Sec. 3107. The state log-scaler, by himself or his deputy, at the request of the owner of any logs or timber or any sheriff, coroner, or constable who has replevied, attached, or levied on

any logs or timber, . . . shall repair to any part of his district and survey such logs or lumber and . . . make out . . . true and correct scale bill thereof . . . and record such in the books of his office. . . . The rule known as the *Drew* rule is hereby adopted as the *only rule* for the survey of logs in this state.

Sec. 3109. It shall be the duty of the state log-scaler or his deputy to scale all lots or booms of logs containing fifty thousand feet or more which may be offered for sale, whether requested to do so or not, if the same has not been scaled, and it shall also be the duty of the owner or purchaser of any logs to notify the state log-scaler of any logs in his possession that have not been scaled, and any person or association of persons who shall sell or remove any such logs from the state, that have been cut in the state, before the same shall have been scaled, shall be liable to the state log-scaler for one-half the value of such logs so sold or removed from the state without having been scaled, which sum shall be recovered by the state log-scaler in a civil action, and when so recovered, one-half thereof shall be paid by the state log-scaler into the general school fund.

West Virginia. Revised Statutes, 1899. The law requires: That Scribner's rule for the measurement of logs, lumber, and timber of all kinds is hereby established as the lawful rule in this state for the measurement of all kinds of lumber, logs, and timber, unless some other rule be agreed to.

Wisconsin. In Wisconsin the law is similar to that of Minnesota already quoted. Extracts from the statutes are given below:

Revised Statutes, 1901. Chap. LXXXIV. Sec. 1730. The state is divided into sixteen districts.

Sec. 1731. The governor shall appoint an inspector for each of the said lumber districts, who shall be styled as inspector of district No. —. His term of office shall be two years.

Sec. 1735. He shall make out scale bills to parties concerned and record the same in his office.

Sec. 1737. The standard rule for scaling or measuring logs

in said districts shall be in accordance with the following table, showing the length of the log in feet, the diameter in inches and the number of feet of lumber, board measure, contained in each log, to wit:

Diam. of Log, Inches.	Length of Log in Feet.			Diam. of Log, Inches.	Length of Log in Feet.		
	12	14	16		12	14	16
6.....	10	10	20	24.....	300	350	400
7.....	20	20	30	25.....	340	400	460
8.....	20	20	30	26.....	370	440	500
9.....	30	30	40	27.....	410	480	550
10.....	30	40	60	28.....	440	510	580
11.....	40	50	70	29.....	460	530	610
12.....	60	70	80	30.....	490	570	660
13.....	70	80	100	31.....	530	620	710
14.....	90	100	110	32.....	550	640	740
15.....	110	120	140	33.....	590	690	780
16.....	120	140	160	34.....	600	700	800
17.....	140	160	180	35.....	660	770	880
18.....	160	190	210	36.....	690	810	920
19.....	180	210	240	37.....	770	900	1030
20.....	210	240	280	38.....	800	930	1070
21.....	230	270	300	39.....	840	980	1120
22.....	250	290	330	40.....	900	1050	1200
23.....	280	330	380				

Other rules may be used at the request of the owner of logs, but in all such cases the bill of the inspector shall state by what rule the logs were scaled or measured.

LIST OF THE MOST IMPORTANT WORKS DEALING WITH FOREST MENSURATION.

THE following list contains the works which seem to the author most useful to American foresters. The list is designed for teachers of forestry and those engaged in research work, as well as for practical foresters.

SPECIAL WORKS ON FOREST MENSURATION.

- BAUR, FRANZ. Die Holzmesskunde. Berlin, 4th ed., 1891.
- BREHMANN, KARL. Anleitung zur Aufnahme der Holzmasse. Berlin, 1857.
— Anleitung zur Holzmesskunst. Berlin, 1868.
- CARTER, P. J. Mensuration of Timber and Timber Crops. Calcutta, India, 1893.
- FROCHOT, ALEXIS. Cubage et Estimation des Bois. Paris, 1887.
- HEYER, GUST. Über die Ermittlungen der Masse, des Alters und des Zuwachses der Holzbestände. Dessau, 1852.
- HEYER, KARL. Anleitung zu forststatistischen Untersuchungen. Giessen, 1846.
- HUFFEL, G. Les Arbres et les Peuplement Forestiers. Paris, 1893.
- KLAUPRECHT. Die Holzmesskunst. Karlsruhe, 1842 and 1846.
- KÖNIG, G. Die Forst-Mathematik mit Anweisung zur Forstvermessung. Gotha, 1835. Revised by Dr. Grebe, 1864.
- KUNZE, M. F. Lehrbuch der Holzmesskunst. Berlin, 1873.
- LANGENBACHER, FERD. Forstmathematik. Berlin, 1875.
- LANGENBACHER, F. L., und NOSSEK, E. A. Lehr- und Handbuch der Holzmesskunde. Leipzig, 1889.
- MLODZIANSKY, A. K. Measuring the Forest Crop. Bull. No. 20, Division of Forestry, U. S. Dept. of Agriculture, 1898.
- MÜLLER, UDO. Lehrbuch der Holzmesskunde. Leipzig, 1902.
- SCHENCK, C. A. Forest Mensuration. Sewanee, Tenn., 1905.
- SCHWAPPACH, ADAM. Leitfaden der Holzmesskunde. Berlin, 1903.
- SMALIAN, L. Beitrag zur Holzmesskunst. Stralsund, 1837.
— Anleitung zur Untersuchung des Waldzustandes. Berlin, 1840.
- THOMPSON, JAS. A Complete Treatise on the Mensuration of Timber. Troy, N. Y., 1805.

WORKS ON FOREST MANAGEMENT CONTAINING CHAPTERS ON FOREST MENSURATION.

- BORGGREVE, B. Die Forstabschätzung, Berlin, 1888.
 D'ARCY, W. E. Preparation of Forest Working Plans in India. Calcutta, India, 1898.
 VON FISCHBACH, C. Lehrbuch der Forstwissenschaft. Berlin, 1886.
 GRANER, F. Die Forstbetriebseinrichtung. Tübingen, 1889.
 VON GUTTENBERG, A. R. Forstbetriebseinrichtung. Wien and Leipzig, 1903.
 HESS, R. Encyclopedie und Methodologie der Forstwissenschaft. Nördlingen, 1885.
 HEYER, GUST. Waldertragsregelung. Leipzig, 1893.
 JUDEICH, F. Die Forsteinrichtung. Dresden, 1893.
 LOREY, TUISKO. Handbuch der Forstwissenschaft. Tübingen, 1888.
 MCGREGOR, J. L. L. Organization and Valuation of Forests. London, 1883.
 SCHLICH, WM. Manual of Forestry, Vol. III. London, 1904.
 STÖTZER, H. Die Forsteinrichtung. Frankfurt, 1898.
 WEBER, RUDOLF. Lehrbuch der Forsteinrichtung. Berlin, 1891.
 WEISE, W. Ertragsregelung. Berlin, 1904.

LITERATURE ON LOG RULES.

- BAUGHMANN, H. R. A. Buyer and Seller (Lumber). Indianapolis, Ind., 1905.
 British Columbia Log Scale. Victoria, B. C., 1895.
 CHAPIN'S Lumber Reckoner. Chicago.
 DABOLL, DAVID A. Ready Reckoner for Ship-builders. Centre Groton, Conn., 1863.
 DANIELS, A. L. Measurement of Sawlogs. Bull. No. 102, State Agric. Exp. Station. Burlington, Vt., 1903.
 DIMICK, LEVERETT. Log Reckoner, Adapted to the Casting of Logs. Glens Falls, N. Y., 1893.
 DREW. Log Scale. Seattle, Wash., 1897.
 Excelsior Lumber and Log Book and Rapid Reckoner. New York, 1887.
 HANNA, J. S. Complete Ready Reckoner. Philadelphia, 1889.
 HERRING, T. F. Directions for Calculating Timber (Round Logs). Beaumont, Tex., 1871.
 HOLLAND, CHARLES T. The Maine Log Rule. 1886.

- KNAPEN, D. M. *The Mechanic's Assistant: or A Thorough Practical Treatise on Mensuration and the Sliding Rule.* 1849.
- ROPP, C. *Commercial Calculator.* Bloomington, Ill., 1889.
- SCRIBNER, J. M. *The Ready Reckoner; for Ship-builders, Boat-builders, and Lumber-merchants.* 4th ed. Rochester, N. Y., 1846.
- ScrIBner's Lumber and Log Book. Rochester, N. Y., 1905.
- SHEPPARD, MAXFIELD. *Tables for Reducing Sawlegs to the Various Standards in Use.* Québec, 1864.
- SIPAULDING, N. W. *Table for the Measurement of Logs.* San Francisco, 1888.

VOLUME TABLES, YIELD TABLES, AND TABLES FOR THE
DETERMINATION OF THE CUBICAL CONTENTS OF LOGS.

- BAUR, FRANZ. *Untersuchungen über den Festgehalt und das Gewicht des Schichtholzes und der Rinde.* Augsburg, 1879.
- *Formzahlen und Massentafeln für die Fichte.* Berlin, 1890.
- *Die Rothbuche in Bezug auf Ertrag, Zuwachs und Form.* Berlin, 1881.
- *Die Fichte in Bezug auf Ertrag, Zuwachs und Form.* Berlin, 1876.
- BEHM, H. *Grubenholz-Kubik Tabelle.* Berlin, 1896.
- *Massentafeln zur Bestimmung des Gehaltes stehenden Fäume.* Berlin, 1886.
- *Kubik Tabelle zur Bestimmung des Inhalts von Rundhölzern.* Berlin, 1901.
- BOHMERLE, KARL. *Formzahlen u. Massentafeln für die Schwarzföhre.* Wien, 1893.
- BURT, E. A. P. *The Railway Rates, Standard Timber Measurer.* London, 1888.
- *Guide to Round Timber Cubing Rule.* London, 1898.
- CARTER, P. J. *Tables for Computing the Cubical Contents of Round Logs.* Rangoon, India, 1899.
- CORDOIN, L. *Tarif usuel pour la réduction des bois carrés.* Paris, 1899.
- VON COTTA, H. *Tafeln zur Bestimmung des Inhalts der runden, geschnittenen und behauenen Hölzer.* Leipzig, 1897.
- EICHHORN, FRITZ. *Ertragstafeln für die Weisstanne.* Berlin, 1902.
- FEISTMANTEL, RUDOLF. *Allgemeine Waldbestandestafeln.* Wien, 1854.
- FRANCON, J. *Tarif de cubage des bois équarris et ronds, évalué en stère et fraction de stère.* Paris, 1889.
- VON GANGHOFER, A. *Der praktische Holzrechner nach Metermass.* Augsburg, 1896.
- GRAVES, H. S. *The Woodsman's Handbook.* Bull. No. 36, U. S. Bureau of Forestry. Washington, 1903.

- GRUNDNER, F. Untersuchungen im Buchenhochwalde. Berlin, 1904.
- HARTIG, T. Kubik und Geld-Tabellen. Berlin, 1874.
- HARTIG, ROBT., und WEBER, R. Holz der Rothbuche. Berlin, 1888.
- Hilfstafeln zur Inhaltsbestimmung von Bäumen und Beständen der Hauptholzarten, herausgegeben nach der Arbeiten des Vereins deutscher forstlicher Versuchsanstalt. Berlin, 1898.
- HOPPUS's Measurer. Edinburgh.
- HORN, W. Formzahlen u. Massentafeln für die Buche. Berlin, 1898.
- HUNDT, Kubierungstabellen neuesten Systems. Passau, 1894.
- KUNZE, M. F. Formzahlen der gemeinen Kiefer. Dresden, 1889.
- Formzahlen der Fichte. Dresden, 1889.
- Hilfstafeln für Holzmassen Aufnahmen. Berlin, 1884.
- LIZIUS. Taschenbuch für Berechnung des Kubikinhaltes von Rundhölzern, Latten, etc. Stuttgart, 1892.
- LOREY, TUISKO. Über Baumassentafeln. Tübingen, 1882.
- Ertragstafeln für die Weisstanne. Frankfurt, 1884 and 1897.
- Ertragstafeln für die Fichte. Frankfurt, 1899.
- NEUMEISTER, MAX. Anfang zu den forstlichen Kubierungstafeln von Pressler-Neumeister. Wien, 1892.
- Forstliche Kubierungstafeln. Wien, 1898.
- PABST, G. Tafeln zur Inhaltsbestimmung. Gera, 1870.
- PHILIPP, K. Hilfstafeln für Forsttaxatoren. Karlsruhe. 1896.
- PRESSLER, M. R. Forstliche Kubierungstafeln nach metrischem System. Leipzig, 1871. Revised edition by M. Neumeister, 1898.
- Holzwirtschaftliche Tafeln mit populären Erläuterungen. Tharandt, u. Leipzig, 1881-2.
- PREZNEAUX, E. Tarif pour le cubage des bois en grume et équarris. Paris, 1889.
- RAUSCH, J. Hilfstafeln zur Ermittlung des Massengehalts von Blochen, Stämmen u. Stangen. Berlin, 1886.
- SCHENCK, C. A. The Yellow Poplar. 1903.
- SCHUBERG, K. Formzahlen u. Massentafeln für die Weisstanne. Berlin, 1891.
- Aus deutschen Forsten. I. Die Weisstanne. Tübingen, 1888.
- Aus deutschen Forsten. II. Die Rothbuche. Tübingen, 1894.
- Formzahlen u. Massentafeln für die Weisstanne. Berlin, 1891.
- Zur Betriebsstatistik im Mittelwalde. Berlin, 1898.
- SCHWAPPACH, A. Formzahlen u. Massentafeln für die Kiefer. Berlin, 1890.
- Wachstum u. Ertrag normaler Fichtenbestände. Berlin, 1890.
- Wachstum u. Ertrag normaler Kiefernbestände in der norddeutschen Tiefebene. Berlin, 1889.

- SCHWAPPACH, A. Wachstum u. Ertrag normaler Rotbuchenbestände. Berlin, 1893.
 — Untersuchungen über Zuwachs u. Form der Schwarzerle. Neudamm, 1902.
 — Neue Untersuchungen über Wachstum und Ertrag Kieferbestände im norddeutschen Tiefebene. Berlin, 1896.
 — Formzahlen u. Massentafeln für die Kiefer. Berlin, 1900.
 — Formzahlen und Massentafeln für die Eiche. Berlin, 1905.
 SCHIFFEL, A. Die Fichte. Wien, 1899.
 — Form und Inhalt der Lärche. Wein, 1905.
 SPEIDEL, E. Beiträge zu den Wuchsgesetzen des Hochwaldes. Tübingen, 1893.
 — Waldbauliche Forschungen in württembergischen Fichtenbeständen. Tübingen, 1889.
 WEISE, W. Ertragsuntersuchungen in Forchensbeständen Württembergs. — Ertragstafeln für die Kiefer. Berlin, 1880.

MISCELLANEOUS.

- BEHRINGER, MARTIN. Schätzung stehenden Fichtenholzes. Berlin, 1900.
 BÖHMERLE, KARL. Versuche über Bestandesmassen-Aufnahmen. Wien, 1854.
 DAVIES, CHARLES. Elements of Drawing and Mensuration applied to Mechanic Arts. 1846.
 DRAUDT, AUGUST. Die Ermittlung der Holzmassen. Giessen, 1860 and 1902.
 EBERHARDT. Die Inhaltsberechnung des Langnutzholzes in der Praxis, mit besonderer Berücksichtigung der in Württemberg geltenden Vorschriften, Berlin, 1894.
 FANKHAUSER, F. Praktische Anleitung zur Holzmassen-Aufnahme. Berlin, 1889.
 — Praktische Anleitung zur Bestandesaufnahme mit Rücksicht auf die Bedürfnisse der Wirtschaftseinrichtung der Schweiz. Bern, 1891.
 Forest Reserve Manual, Gen. Land Office, Dept. of Interior. Washington 1902.
 Forst und Jagd Kalender. Berlin, 1906.
 GANGHOFER, AUG. Das forstliche Versuchswesen. Augsburg, 1881-1884.
 GEHRHARDT, E. Die theoretische u. praktische Bedeutung des arithmetischen Mittelstammes. Meiningen, 1901.

- GRAVES, H. S. Practical Forestry in the Adirondacks. Bull. No. 26, Bureau of Forestry, U. S. Dept. of Agriculture. Washington, 1899.
- HEYER, EDWARD. Zur Holzmassenermittlung, etc. Giessen, 1861.
- Über Messung der Höhen sowie der Durchmesser. Giessen, 1870.
- HOSMER AND BRUCE. Working Plan for Township 40 (N. Y.). Bull. No. 30, Bureau of Forestry, U. S. Dept. of Agriculture. Washington, 1902.
- KALK, RICHARD. Der Zuwachs an Baumquersfläche, Baummasse u. Bestandsmasse. Berlin, 1889.
- KARL, H. Abhandlung über die Ermittlung des richtigen Holzbestandsalters, etc. Frankfurt, 1847.
- KOHLI. Anleitung zur Abschätzung stehender Kiefern, etc. Berlin, 1861.
- KRAFT, GUSTAV. Beiträge zur forstlichen Zuwachsrechnung und zur Lehre vom Weiserprozent. Hannover, 1885.
- KUNZE, M. F. Anleitung zur Aufnahme des Holzgehaltes der Waldbestände, Berlin, 1891.
- Neue Methoden zur raschen Berechnung der unächten Schaftformzahlen der Fichte u. Kiefer. Dresden, 1891.
- LOREY, TUISKO. Über Probestämme. Frankfurt, 1877.
- Über Stammanalysen. Stuttgart, 1880.
- DE MONTRICHARD. Notice sur la règle à cubage des arbres. Paris, 1899.
- OETZEL, GEORG. Neue Formeln zur Berechnung des Rauminhaltes voller und abgestutzter Baumschäfte. Wien und Leipzig, 1892.
- OLMSTED, F. E. Working Plan for Forest Lands near Pine Bluff, Ark. Bull. No. 32, Bureau of Forestry, U. S. Dept. of Agriculture. Washington, 1902.
- PINCHOT, GIFFORD. The Adirondack Spruce. New York, 1898.
- PINCHOT AND GRAVES. The White Pine. New York, 1896.
- PUSCHEL, ALFRED. Die Baummessung u. Inhaltsberechnung nach Formzahlen u. Massentafeln. Leipzig, 1871.
- PRESSLER, M. R. Der Messknecht, etc. Braunschweig, 1852.
- Neue holzwirtschaftliche Tafeln. Dresden, 1857.
- Gesetze der Stammbildung. Leipzig, 1865.
- RAIT, JAS. The Relative Value of Round and Sawn Timber.
- RUCKE, FRIEDR. Über die Berechnung des körperlichen Inhalts unbeschlagener Baumstämme. Stuttgart, 1849.
- RINIKER, HANS. Über Baumform u. Bestandsmasse. Aarau, 1873.
- SCHIFFEL, A. Die Kubierung von Rundholz. Wien, 1902.
- SHERRARD, THOS. H. Report on Tract of the Okeetee Club near Ridgeway, S. C. Bull. No. 43, Bureau of Forestry, U. S. Dept. of Agriculture. Washington.

- SIMONY, OSKAR. Über das Problem der Stammcubirung als Grundlage der Berechnung von Formzahl tabellen u. Massentafeln. Wien, 1879.
- Die näherungsweise Körperberechnung in der wissenschaftliche Holzmesskunde. Wien, 1901.
- Über Formzahlen-gleichungen u. deren forstmathematische Verwertung. Wien, 1903.
- The Use Book. U. S. Forest Service. Washington, 1906.
- WALTHER. Die Ermittlung der Bestandsholzmassen mit Hilfe der Bestandsrichthöhe. Giessen, 1886.
- WEBER, JACOB. Holzmassenermittlungen auf Grund photographischen Aufnahmen. Giessen, 1902.
- ZON, R. Chestnut in Southern Maryland. Bull. No. 53, U. S. Forest Service. Washington, 1904.
- The Loblolly Pine in Eastern Texas. Bull. No. 64, U. S. Forest Service. Washington, 1905.

A large amount of information regarding forest mensuration is found in the technical forest journals. The most important, in English, German, and French, are the following:

- Forestry and Irrigation. Washington, D. C.
- Forestry Quarterly. Ithaca, N. Y.
- The Indian Forester. Allahabad, India.
- Kritische Blätter. Leipzig, 1823-1870.
- Aus dem Walde. Hannover, 1865-1881.
- Allgemeine Forst- und Jagdzeitung. Frankfurt.
- Forstwissenschaftliches Centralblatt. Berlin.
- Zeitschrift für Forst- und Jagdwesen. Berlin.
- Forstliche Blätter, 1861-1890. Berlin.
- Tharandter Jahrbuch. Tharandt.
- Mündener Forstliche Hefte. Münden.
- Schweizerische Zeitschrift für das Forstwesen. Zurich.
- Mittheilungen der Centralanstalt für das forstliche Versuchswesen. Zurich.
- Oesterreichische Vierteljahresschrift für Forstwesen. Wien.
- Centralblatt für das gesammte Forstwesen. Wien.
- Mittheilungen aus dem forstlichen Versuchswesen Oesterreichs. Wien.
- Revue des Eaux et Forêts. Paris.
- Bulletins of Société de Franche Compté et Belfort. Besançon.

TABLES SHOWING THE CONTENTS OF LOGS.

In the following pages are given several tables showing the contents of logs in cubic and cord measure. The first table serves a double purpose. It shows, in the first place, the contents of cylinders of different diameters and lengths. It may be used to determine the contents of logs whose diameters are measured at the middle. The table shows also the sums of the basal areas of different numbers of trees. Thus, the total basal area of 51 trees 9 inches in diameter is 22.53 square feet. This table will be found very useful in computing the total basal area, of different diameter classes in valuation surveys.

The second table, showing the cubic contents of cylinders in cubic meters, is given for the benefit of the Philippine foresters and others using the metric system. The other tables require no special explanation.

The common log tables in board measure are not included, as they are readily accessible and are usually in the possession of any forester who might have occasion to use this work.

CUBIC CONTENTS OF CYLINDERS AND MULTIPLE TABLE OF
BASAL AREAS.

Length, Feet, or Number of Trees.	Diameter in Inches.						
	2	3	4	5	6	7	8
	Contents of Cylinders in Cubic Feet. or Basal Areas in Square Feet.						
1	0.02	0.05	0.09	0.14	0.20	0.27	0.35
2	0.04	0.10	0.17	0.27	0.39	0.53	0.70
3	0.07	0.15	0.26	0.41	0.59	0.80	1.05
4	0.09	0.20	0.35	0.55	0.79	1.07	1.40
5	0.11	0.25	0.44	0.68	0.98	1.34	1.75
6	0.13	0.29	0.52	0.82	1.18	1.60	2.09
7	0.15	0.34	0.61	0.95	1.37	1.87	2.44
8	0.17	0.39	0.70	1.09	1.57	2.14	2.79
9	0.20	0.44	0.79	1.23	1.77	2.41	3.14
10	0.22	0.49	0.87	1.36	1.96	2.67	3.49
11	0.24	0.54	0.96	1.50	2.16	2.94	3.84
12	0.26	0.59	1.05	1.64	2.36	3.21	4.19
13	0.28	0.64	1.13	1.77	2.55	3.47	4.54
14	0.31	0.69	1.22	1.91	2.75	3.74	4.89
15	0.33	0.74	1.31	2.05	2.95	4.01	5.24
16	0.35	0.79	1.40	2.18	3.14	4.28	5.59
17	0.37	0.83	1.48	2.32	3.34	4.54	5.93
18	0.39	0.88	1.57	2.45	3.53	4.81	6.28
19	0.41	0.93	1.66	2.59	3.73	5.08	6.63
20	0.44	0.98	1.75	2.73	3.93	5.35	6.98
21	0.46	1.03	1.83	2.86	4.12	5.61	7.33
22	0.48	1.08	1.92	3.00	4.32	5.88	7.68
23	0.50	1.13	2.01	3.14	4.52	6.15	8.03
24	0.52	1.18	2.09	3.27	4.71	6.41	8.38
25	0.55	1.23	2.18	3.41	4.91	6.68	8.73
26	0.57	1.28	2.27	3.55	5.11	6.95	9.08
27	0.59	1.33	2.36	3.68	5.30	7.22	9.42
28	0.61	1.37	2.44	3.82	5.50	7.48	9.77
29	0.63	1.42	2.53	3.95	5.69	7.75	10.12
30	0.65	1.47	2.62	4.09	5.89	8.02	10.47
31	0.68	1.52	2.71	4.23	6.09	8.28	10.82
32	0.70	1.57	2.79	4.36	6.28	8.55	11.17
33	0.72	1.62	2.88	4.50	6.48	8.82	11.52
34	0.74	1.67	2.97	4.64	6.68	9.09	11.87
35	0.76	1.72	3.05	4.77	6.87	9.35	12.22
36	0.79	1.77	3.14	4.91	7.07	9.62	12.57
37	0.81	1.82	3.23	5.05	7.26	9.89	12.92

CUBIC CONTENTS OF CYLINDERS AND MULTIPLE TABLE OF BASAL AREAS—(Continued).

Length, Feet, or Number of Trees.	Diameter in Inches.						
	2	3	4	5	6	7	8
	Contents of Cylinders in Cubic Feet, or Basal Areas in Square Feet.						
38	0.83	1.87	3.32	5.18	7.46	10.16	13.26
39	0.85	1.91	3.40	5.32	7.66	10.42	13.61
40	0.87	1.96	3.49	5.45	7.85	10.69	13.96
41	0.89	2.01	3.58	5.59	8.05	10.96	14.31
42	0.92	2.06	3.67	5.73	8.25	11.22	14.66
43	0.94	2.11	3.75	5.86	8.44	11.49	15.01
44	0.96	2.16	3.84	6.00	8.64	11.76	15.36
45	0.98	2.21	3.93	6.14	8.84	12.03	15.71
46	1.00	2.26	4.01	6.27	9.03	12.29	16.06
47	1.03	2.31	4.10	6.41	9.23	12.56	16.41
48	1.05	2.36	4.19	6.54	9.42	12.83	16.76
49	1.07	2.41	4.28	6.68	9.62	13.10	17.10
50	1.09	2.45	4.36	6.82	9.82	13.36	17.45
51	1.11	2.50	4.45	6.95	10.01	13.63	17.80
52	1.13	2.55	4.54	7.09	10.21	13.90	18.15
53	1.16	2.60	4.63	7.23	10.41	14.16	18.50
54	1.18	2.65	4.71	7.36	10.60	14.43	18.85
55	1.20	2.70	4.80	7.50	10.80	14.70	19.20
56	1.22	2.75	4.89	7.64	11.00	14.97	19.55
57	1.24	2.80	4.97	7.77	11.19	15.23	19.90
58	1.27	2.85	5.06	7.91	11.39	15.50	20.25
59	1.29	2.90	5.15	8.04	11.58	15.77	20.60
60	1.31	2.95	5.24	8.18	11.78	16.04	20.94
61	1.33	2.99	5.32	8.32	11.98	16.30	21.29
62	1.35	3.04	5.41	8.45	12.17	16.57	21.64
63	1.37	3.09	5.50	8.59	12.37	16.84	21.99
64	1.40	3.14	5.59	8.73	12.57	17.10	22.34
65	1.42	3.19	5.67	8.86	12.76	17.37	22.69
66	1.44	3.24	5.76	9.00	12.96	17.64	23.04
67	1.46	3.29	5.85	9.14	13.16	17.91	23.39
68	1.48	3.34	5.93	9.27	13.35	18.17	23.74
69	1.51	3.39	6.02	9.41	13.55	18.44	24.09
70	1.53	3.44	6.11	9.54	13.74	18.71	24.43
71	1.55	3.49	6.20	9.68	13.94	18.97	24.78
72	1.57	3.54	6.28	9.82	14.14	19.24	25.13
73	1.59	3.58	6.37	9.95	14.33	19.51	25.48
74	1.61	3.63	6.46	10.09	14.53	19.78	25.83
75	1.64	3.68	6.54	10.23	14.73	20.04	26.18

CUBIC CONTENTS OF CYLINDERS AND MULTIPLE TABLE OF
BASAL AREAS—(Continued).

Length, Feet, or Number of Trees.	Diameter in Inches.						
	9	10	11	12	13	14	15
	Contents of Cylinders in Cubic Feet, or Basal Areas in Square Feet.						
1	0.44	0.55	0.66	0.79	0.92	1.07	1.23
2	0.88	1.09	1.32	1.57	1.84	2.14	2.45
3	1.33	1.64	1.98	2.36	2.77	3.21	3.68
4	1.77	2.18	2.64	3.14	3.69	4.28	4.91
5	2.21	2.73	3.30	3.93	4.61	5.35	6.14
6	2.65	3.27	3.96	4.71	5.53	6.41	7.36
7	3.09	3.82	4.62	5.50	6.45	7.48	8.59
8	3.53	4.36	5.28	6.28	7.37	8.55	9.82
9	3.98	4.91	5.94	7.07	8.30	9.62	11.04
10	4.42	5.45	6.60	7.85	9.22	10.69	12.27
11	4.86	6.00	7.26	8.64	10.14	11.76	13.50
12	5.30	6.55	7.92	9.42	11.06	12.83	14.73
13	5.74	7.09	8.58	10.21	11.98	13.90	15.95
14	6.19	7.64	9.24	11.00	12.90	14.97	17.18
15	6.63	8.18	9.90	11.78	13.83	16.04	18.41
16	7.07	8.73	10.56	12.57	14.75	17.10	19.63
17	7.51	9.27	11.22	13.35	15.67	18.17	20.86
18	7.95	9.82	11.88	14.14	16.59	19.24	22.09
19	8.39	10.36	12.54	14.92	17.51	20.31	23.32
20	8.84	10.91	13.20	15.71	18.44	21.38	24.54
21	9.28	11.45	13.86	16.49	19.36	22.45	25.77
22	9.72	12.00	14.52	17.28	20.28	23.52	27.00
23	10.16	12.54	15.18	18.06	21.20	24.59	28.23
24	10.60	13.09	15.84	18.85	22.12	25.66	29.45
25	11.04	13.64	16.50	19.64	23.04	26.73	30.68
26	11.49	14.18	17.16	20.42	23.97	27.79	31.91
27	11.93	14.73	17.82	21.21	24.89	28.86	33.13
28	12.37	15.27	18.48	21.99	25.81	29.93	34.36
29	12.81	15.82	19.14	22.78	26.73	31.00	35.59
30	13.25	16.36	19.80	23.56	27.65	32.07	36.82
31	13.70	16.91	20.46	24.35	28.57	33.14	38.04
32	14.14	17.45	21.12	25.13	29.50	34.21	39.27
33	14.58	18.00	21.78	25.92	30.42	35.28	40.50
34	15.02	18.54	22.44	26.70	31.34	36.35	41.72
35	15.46	19.09	23.10	27.49	32.26	37.42	42.95
36	15.90	19.64	23.76	28.27	33.18	38.48	44.18
37	16.35	20.18	24.42	29.06	34.10	39.55	45.41

CUBIC CONTENTS OF CYLINDERS AND MULTIPLE TABLE OF BASAL AREAS—(Continued).

Length, Feet, or Number of Trees.	Diameter in Inches.						
	9	10	11	12	13	14	15
	Contents of Cylinders in Cubic Feet, or Basal Areas in Square Feet.						
38	16.79	20.73	25.08	29.85	35.03	40.62	46.63
39	17.23	21.27	25.74	30.63	35.95	41.69	47.86
40	17.67	21.82	26.40	31.42	36.87	42.76	49.09
41	18.11	22.36	27.06	32.20	37.79	43.83	50.31
42	18.56	22.91	27.72	32.99	38.71	44.90	51.54
43	19.00	23.45	28.38	33.77	39.64	45.97	52.77
44	19.44	24.00	29.04	34.56	40.56	47.04	54.00
45	19.88	24.54	29.70	35.34	41.48	48.11	55.22
46	20.32	25.09	30.36	36.13	42.40	49.17	56.45
47	20.76	25.63	31.02	36.91	43.32	50.24	57.68
48	21.21	26.18	31.68	37.70	44.24	51.31	58.90
49	21.65	26.73	32.34	38.48	45.17	52.38	60.13
50	22.09	27.27	33.00	39.27	46.09	53.45	61.36
51	22.53	27.82	33.66	40.06	47.01	54.52	62.59
52	22.97	28.36	34.32	40.84	47.93	55.59	63.81
53	23.41	28.91	34.98	41.63	48.85	56.66	65.04
54	23.86	29.45	35.64	42.41	49.77	57.73	66.27
55	24.30	30.00	36.30	43.20	50.70	58.80	67.49
56	24.74	30.54	36.96	43.98	51.62	59.86	68.72
57	25.18	31.08	37.62	44.77	52.54	60.93	69.95
58	25.62	31.63	38.28	45.55	53.46	62.00	71.18
59	26.07	32.18	38.94	46.34	54.38	63.07	72.40
60	26.51	32.73	39.60	47.12	55.31	64.14	73.63
61	26.95	33.27	40.26	47.91	56.23	65.21	74.86
62	27.39	33.82	40.92	48.69	57.15	66.28	76.09
63	27.83	34.36	41.58	49.48	58.07	67.35	77.31
64	28.27	34.91	42.24	50.27	58.99	68.42	78.54
65	28.72	35.45	42.90	51.05	59.91	69.49	79.77
66	29.16	36.00	43.56	51.84	60.84	70.55	80.99
67	29.60	36.54	44.22	52.62	61.76	71.62	82.22
68	30.04	37.09	44.88	53.41	62.68	72.69	83.45
69	30.48	37.63	45.54	54.19	63.60	73.76	84.68
70	30.93	38.18	46.20	54.98	64.52	74.83	85.90
71	31.37	38.72	46.86	55.76	65.44	75.90	87.13
72	31.81	39.27	47.52	56.55	66.37	76.97	88.36
73	32.25	39.82	48.18	57.33	67.29	78.04	89.58
74	32.69	40.36	48.84	58.12	68.21	79.11	90.81
75	33.13	40.91	49.50	58.91	69.13	80.18	92.04

CUBIC CONTENTS OF CYLINDERS AND MULTIPLE TABLE OF
BASAL AREAS—(Continued).

Length, Feet, or Number of Trees.	Diameter in Inches.						
	16	17	18	19	20	21	22
	Contents of Cylinders in Cubic Feet, or Basal Areas in Square Feet.						
1	1.40	1.58	1.77	1.97	2.18	2.41	2.64
2	2.79	3.15	3.53	3.94	4.36	4.81	5.28
3	4.19	4.73	5.30	5.91	6.54	7.22	7.92
4	5.59	6.31	7.07	7.88	8.73	9.62	10.56
5	6.98	7.88	8.84	9.84	10.91	12.03	13.20
6	8.38	9.46	10.60	11.81	13.09	14.43	15.84
7	9.77	11.03	12.37	13.78	15.27	16.84	18.48
8	11.17	12.61	14.14	15.75	17.45	19.24	21.12
9	12.57	14.19	15.90	17.72	19.63	21.65	23.76
10	13.96	15.76	17.67	19.69	21.82	24.05	26.40
11	15.36	17.34	19.44	21.66	24.00	26.46	29.04
12	16.76	18.92	21.21	23.63	26.18	28.86	31.68
13	18.15	20.49	22.97	25.60	28.36	31.27	34.32
14	19.55	22.07	24.74	27.57	30.54	33.67	36.96
15	20.94	23.64	26.51	29.53	32.72	36.08	39.60
16	22.34	25.22	28.27	31.50	34.91	38.48	42.24
17	23.74	26.80	30.04	33.47	37.09	40.89	44.88
18	25.13	28.37	31.81	35.44	39.27	43.30	47.52
19	26.53	29.95	33.58	37.41	41.45	45.70	50.16
20	27.93	31.53	35.34	39.38	43.63	48.11	52.80
21	29.32	33.10	37.11	41.35	45.82	50.51	55.44
22	30.72	34.68	38.88	43.32	48.00	52.92	58.08
23	32.11	36.25	40.64	45.29	50.18	55.32	60.72
24	33.51	37.83	42.41	47.25	52.36	57.73	63.36
25	34.91	39.41	44.18	49.22	54.54	60.13	66.00
26	36.30	40.98	45.95	51.19	56.72	62.54	68.64
27	37.70	42.56	47.71	53.16	58.90	64.94	71.27
28	39.10	44.14	49.48	55.13	61.09	67.35	73.91
29	40.49	45.71	51.25	57.10	63.27	69.75	76.55
30	41.89	47.29	53.01	59.07	65.45	72.16	79.19
31	43.28	48.86	54.78	61.04	67.63	74.56	81.83
32	44.68	50.44	56.55	63.01	69.81	76.97	84.47
33	46.08	52.02	58.32	64.98	71.99	79.37	87.11
34	47.47	53.59	60.08	66.94	74.18	81.78	89.75
35	48.87	55.17	61.85	68.91	76.36	84.18	92.39
36	50.27	56.75	63.62	70.88	78.54	86.59	95.03
37	51.66	58.32	65.38	72.85	80.72	89.00	97.67

CUBIC CONTENTS OF CYLINDERS AND MULTIPLE TABLE OF BASAL AREAS—(Continued).

Length, Feet, or Number of Trees.	Diameter in Inches.						
	16	17	18	19	20	21	22
	Contents of Cylinders in Cubic Feet, or Basal Areas in Square Feet.						
38	53.06	59.90	67.15	74.82	82.90	91.40	100.31
39	54.45	61.47	68.92	76.79	85.08	93.81	102.95
40	55.85	63.05	70.69	78.76	87.27	96.21	105.59
41	57.25	64.63	72.45	80.73	89.45	98.62	108.23
42	58.64	66.20	74.22	82.70	91.63	101.02	110.87
43	60.04	67.78	75.99	84.66	93.81	103.43	113.51
44	61.44	69.36	77.75	86.63	95.99	105.83	116.15
45	62.83	70.93	79.52	88.60	98.17	108.24	118.79
46	64.23	72.51	81.29	90.57	100.36	110.64	121.43
47	65.62	74.08	83.06	92.54	102.54	113.05	124.07
48	67.02	75.66	84.82	94.51	104.72	115.45	126.71
49	68.42	77.24	86.59	96.48	106.90	117.86	129.35
50	69.81	78.81	88.36	98.45	109.08	120.26	131.99
51	71.21	80.39	90.12	100.42	111.26	122.67	134.63
52	72.61	81.97	91.89	102.39	113.45	125.07	137.27
53	74.00	83.54	93.66	104.35	115.63	127.48	139.91
54	75.40	85.12	95.43	106.32	117.81	129.89	142.55
55	76.79	86.69	97.19	108.29	119.99	132.29	145.19
56	78.19	88.27	98.96	110.26	122.17	134.70	147.83
57	79.59	89.85	100.73	112.23	124.35	137.10	150.47
58	80.98	91.42	102.49	114.20	126.54	139.51	153.11
59	82.38	93.00	104.26	116.17	128.72	141.91	155.75
60	83.78	94.58	106.03	118.14	130.90	144.32	158.39
61	85.17	96.15	107.80	120.11	133.08	146.72	161.03
62	86.57	97.73	109.56	122.07	135.26	149.13	163.67
63	87.96	99.30	111.33	124.04	137.44	151.53	166.31
64	89.36	100.88	113.10	126.01	139.63	153.94	168.95
65	90.76	102.46	114.86	127.98	141.81	156.34	171.59
66	92.15	104.03	116.63	129.95	143.99	158.75	174.23
67	93.55	105.61	118.40	131.92	146.17	161.15	176.87
68	94.95	107.19	120.17	133.89	148.35	163.56	179.51
69	96.34	108.76	121.93	135.86	150.53	165.96	182.15
70	97.74	110.34	123.70	137.83	152.72	168.37	184.79
71	99.13	111.91	125.47	139.80	154.90	170.77	187.43
72	100.53	113.49	127.23	141.76	157.08	173.18	190.07
73	101.93	115.07	129.00	143.73	159.26	175.59	192.71
74	103.32	116.64	130.77	145.70	161.44	177.99	195.35
75	104.72	118.22	132.54	147.67	163.62	180.40	197.99

CUBIC CONTENTS OF CYLINDERS AND MULTIPLE TABLE OF
BASAL AREAS—(Continued).

Length, Feet, or Number of Trees.	Diameter in Inches.						
	23	24	25	26	27	28	29
	Contents of Cylinders in Cubic Feet, or Basal Areas in Square Feet.						
1	2.89	3.14	3.41	3.69	3.98	4.29	4.59
2	5.77	6.28	6.82	7.37	7.95	8.55	9.17
3	8.66	9.42	10.23	11.06	11.93	12.83	13.76
4	11.54	12.57	13.64	14.75	15.90	17.10	18.35
5	14.43	15.71	17.04	18.44	19.88	21.38	22.93
6	17.31	18.85	20.45	22.12	23.86	25.66	27.52
7	20.20	21.99	23.86	25.81	27.83	29.93	32.11
8	23.08	25.13	27.27	29.50	31.81	34.21	36.70
9	25.97	28.27	30.68	33.18	35.78	38.48	41.28
10	28.85	31.42	34.09	36.87	39.76	42.76	45.87
11	31.74	34.56	37.50	40.56	43.74	47.04	50.46
12	34.62	37.70	40.91	44.24	47.71	51.31	55.04
13	37.51	40.84	44.31	47.93	51.69	55.59	59.63
14	40.39	43.98	47.72	51.62	55.67	59.86	64.22
15	43.28	47.12	51.13	55.31	59.64	64.14	68.80
16	46.16	50.27	54.54	58.99	63.62	68.42	73.39
17	49.05	53.41	57.95	62.68	67.59	72.69	77.98
18	51.93	56.55	61.36	66.37	71.57	76.97	82.56
19	54.82	59.69	64.77	70.05	75.55	81.24	87.15
20	57.71	62.83	68.18	73.74	79.52	85.52	91.74
21	60.59	65.97	71.59	77.43	83.50	89.80	96.33
22	63.48	69.11	74.99	81.11	87.47	94.07	100.91
23	66.36	72.26	78.40	84.80	91.45	98.35	105.50
24	69.25	75.40	81.81	88.49	95.43	102.63	110.09
25	72.13	78.54	85.22	92.18	99.40	106.90	114.67
26	75.02	81.68	88.63	95.86	103.38	111.18	119.26
27	77.90	84.82	92.04	99.55	107.35	115.45	123.85
28	80.79	87.96	95.45	103.24	111.33	119.73	128.43
29	83.67	91.11	98.86	106.92	115.31	124.01	133.02
30	86.56	94.25	102.27	110.61	119.28	128.28	137.61
31	89.44	97.39	105.67	114.30	123.26	132.56	142.20
32	92.33	100.53	109.08	117.98	127.23	136.83	146.78
33	95.21	103.67	112.49	121.67	131.21	141.11	151.37
34	98.10	106.81	115.90	125.36	135.19	145.39	155.96
35	100.98	109.96	119.31	129.05	139.16	149.66	160.54
36	103.87	113.10	122.72	132.73	143.14	153.94	165.13
37	106.75	116.24	126.13	136.42	147.11	158.21	169.72

CUBIC CONTENTS OF CYLINDERS AND MULTIPLE TABLE OF BASAL AREAS—(Continued).

Length, Feet, or Number of Trees.	Diameter in Inches.						
	23	24	25	26	27	28	29
	Contents of Cylinders in Cubic Feet, or Basal Areas in Square Feet.						
38	109.64	119.38	129.54	140.11	151.09	162.49	174.30
39	112.52	122.52	132.94	143.79	155.07	166.77	178.89
40	115.41	125.66	136.35	147.48	159.04	171.04	183.48
41	118.30	128.81	139.76	151.17	163.02	175.32	188.06
42	121.18	131.95	143.17	154.85	167.00	179.59	192.65
43	124.07	135.09	146.58	158.54	170.97	183.87	197.24
44	126.95	138.23	149.99	162.23	174.95	188.15	201.83
45	129.84	141.37	153.40	165.92	178.92	192.42	206.41
46	132.72	144.51	156.81	169.60	182.90	196.70	211.00
47	135.61	147.65	160.22	173.29	186.88	200.97	215.59
48	138.49	150.80	163.62	176.98	190.85	205.25	220.17
49	141.38	153.94	167.03	180.66	194.83	209.53	224.76
50	144.26	157.08	170.44	184.35	198.80	213.80	229.35
51	147.15	160.22	173.85	188.04	202.78	218.08	233.93
52	150.03	163.36	177.26	191.72	206.76	222.35	238.52
53	152.92	166.50	180.67	195.41	210.73	226.63	243.11
54	155.80	169.65	184.08	199.10	214.71	230.91	247.69
55	158.69	172.79	187.49	202.79	216.68	235.18	252.28
56	161.57	175.93	190.90	206.47	222.66	239.46	256.87
57	164.46	179.07	194.30	210.16	226.64	243.73	261.46
58	167.34	182.21	197.71	213.85	230.61	248.01	266.04
59	170.23	185.35	201.12	217.53	234.59	252.29	270.63
60	173.12	188.50	204.53	221.22	238.56	256.56	275.22
61	176.00	191.64	207.94	224.91	242.54	260.84	279.80
62	178.89	194.78	211.35	228.59	246.52	265.12	284.39
63	181.77	197.92	214.76	232.28	250.49	269.39	288.98
64	184.66	201.06	218.17	235.97	254.47	273.67	293.56
65	187.54	204.20	221.57	239.66	258.45	277.94	298.15
66	190.43	207.34	224.98	243.34	262.42	282.22	302.74
67	193.31	210.49	228.39	247.03	266.40	286.50	307.32
68	196.20	213.63	231.80	250.72	270.37	290.77	311.91
69	199.08	216.77	235.21	254.40	274.35	295.05	316.50
70	201.97	219.91	238.62	258.09	278.33	299.32	321.09
71	204.85	223.05	242.03	261.78	282.30	303.60	325.67
72	207.74	226.19	245.44	265.46	286.28	307.88	330.26
73	210.62	229.34	248.85	269.15	290.25	312.15	334.85
74	213.51	232.48	252.25	272.84	294.23	316.42	339.43
75	216.39	235.62	255.66	276.53	298.21	320.70	344.02

CUBIC CONTENTS OF CYLINDERS AND MULTIPLE TABLE OF BASAL AREAS—(Continued).

Length, Feet, or Number of Trees.	Diameter in Inches.						
	30	31	32	33	34	35	36
	Contents of Cylinders in Cubic Feet, or Basal Areas in Square Feet.						
1	4.91	5.24	5.59	5.94	6.30	6.68	7.07
2	9.82	10.48	11.17	11.88	12.61	13.36	14.14
3	14.73	15.72	16.76	17.82	18.92	20.44	21.21
4	19.63	20.97	22.34	23.76	25.22	26.73	28.27
5	24.54	26.21	27.93	29.70	31.53	33.41	35.34
6	29.45	31.45	33.51	35.64	37.83	40.09	42.41
7	34.36	36.69	39.10	41.58	44.14	46.77	49.48
8	39.27	41.93	44.68	47.52	50.44	53.45	56.55
9	44.18	47.17	50.27	53.46	56.75	60.13	63.62
10	49.09	52.41	55.85	59.40	63.05	66.81	70.69
11	54.00	57.66	61.44	65.34	69.36	73.49	77.75
12	58.90	62.90	67.02	71.27	75.66	80.18	84.82
13	63.81	68.14	72.61	77.21	81.97	86.86	91.89
14	68.72	73.38	78.19	83.15	88.27	93.54	98.96
15	73.63	73.62	83.78	89.09	94.58	100.22	106.03
16	78.54	83.86	89.36	95.03	100.88	106.90	113.10
17	83.45	89.10	94.95	100.97	107.18	113.58	120.17
18	88.36	94.35	100.53	106.91	113.49	120.26	127.23
19	93.27	99.59	106.12	112.85	119.80	126.95	134.30
20	98.17	104.83	111.70	118.79	126.10	133.63	141.37
21	103.08	110.07	117.29	124.73	132.41	140.31	148.44
22	107.99	115.31	122.87	130.67	138.71	146.99	155.51
23	112.90	120.55	128.46	136.61	145.02	153.67	162.58
24	117.81	125.79	134.04	142.55	151.32	160.35	169.65
25	122.72	131.04	139.63	148.49	157.63	167.03	176.71
26	127.63	136.28	145.21	154.43	163.93	173.71	183.78
27	132.54	141.52	150.80	160.37	170.24	180.40	190.85
28	137.44	146.76	156.38	166.31	176.54	187.08	197.92
29	142.35	152.00	161.97	172.25	182.85	193.76	204.99
30	147.26	157.24	167.55	178.19	189.15	200.44	212.06
31	152.17	162.48	173.14	184.13	195.45	207.12	219.13
32	157.08	167.73	178.72	190.07	201.76	213.80	226.19
33	161.99	172.97	184.31	196.01	208.06	220.48	233.26
34	166.90	178.21	189.89	201.95	214.37	227.17	240.33
35	171.81	183.45	195.48	207.88	220.68	233.85	247.40
36	176.71	188.69	201.06	213.82	226.98	240.53	254.47
37	181.62	193.93	206.65	219.76	233.28	247.21	261.54

CUBIC CONTENTS OF CYLINDERS AND MULTIPLE TABLE OF BASAL AREAS—(Continued).

Length, Feet, or Number of Trees.	Diameter in Inches.						
	30	31	32	33	34	35	36
	Contents of Cylinders in Cubic Feet, or Basal Areas in Square Feet.						
38	186.53	199.17	212.23	225.70	239.59	253.89	268.61
39	191.44	204.42	217.82	231.64	245.89	260.57	275.67
40	196.35	209.66	223.40	237.58	252.20	267.25	282.74
41	201.26	214.90	228.99	243.52	258.50	273.93	289.81
42	206.17	220.14	234.57	249.46	264.81	280.62	296.88
43	211.08	225.38	240.16	255.40	271.11	287.30	303.95
44	215.98	230.62	245.74	261.34	277.42	293.98	311.02
45	220.89	235.86	251.33	267.28	283.72	300.66	318.09
46	225.80	241.11	256.91	273.22	290.03	307.34	325.15
47	230.71	246.35	262.50	279.16	296.33	314.02	332.22
48	235.62	251.59	268.08	285.10	302.64	320.70	339.29
49	240.53	256.83	273.67	291.04	308.94	327.39	346.36
50	245.44	262.07	279.25	296.98	315.25	334.07	353.43
51	250.35	267.31	284.84	302.92	321.55	340.75	360.50
52	255.25	272.55	290.42	308.86	327.86	347.43	367.57
53	260.16	277.80	296.01	314.80	334.16	354.11	374.63
54	265.07	283.04	301.59	320.74	340.47	360.79	381.70
55	269.98	288.28	307.18	326.68	346.77	367.47	388.77
56	274.89	293.52	312.76	332.62	353.08	374.15	395.84
57	279.80	298.76	318.35	338.56	359.38	380.84	402.91
58	284.71	304.00	323.93	344.50	365.69	387.52	409.98
59	289.62	309.24	329.52	350.43	371.99	394.20	417.05
60	294.52	314.49	335.10	356.37	378.30	400.88	424.11
61	299.43	319.73	340.69	362.34	384.61	407.54	431.21
62	304.34	324.97	346.27	368.28	390.91	414.22	438.28
63	309.25	330.21	351.86	374.22	397.22	420.80	445.35
64	314.16	335.45	357.44	380.16	403.52	427.58	452.42
65	319.07	340.69	363.03	386.07	409.82	434.29	459.46
66	323.98	345.93	368.61	392.04	416.13	440.95	466.55
67	328.89	351.18	374.20	397.98	422.44	447.63	473.62
68	333.79	356.42	379.78	403.92	428.74	454.31	480.69
69	338.70	361.66	385.37	409.86	435.05	460.99	487.76
70	343.61	366.90	390.95	415.77	441.35	467.69	494.80
71	348.52	372.14	396.54	421.74	447.66	474.35	501.90
72	353.43	377.38	402.12	427.68	453.96	481.03	508.97
73	358.34	382.62	407.71	433.62	460.27	487.61	516.04
74	363.25	387.87	413.29	439.56	466.57	494.39	523.11
75	368.16	393.11	418.88	445.47	472.87	501.10	530.14

CUBIC CONTENTS OF CYLINDERS.
[Metric System.]

Length, Feet.	Diameter in Centimeters.													Length, Feet.
	1	2	3	4	5	6	7	8	9	10	11	12	13	
	Contents in Cubic Meters.													
1	0.0001	0.0003	0.0007	0.013	0.0020	0.0028	0.0038	0.0050	0.0064	0.0079	0.0095	0.0113	0.0133	
2	0.0002	0.0005	0.0014	0.025	0.0039	0.0057	0.0077	0.0101	0.0127	0.0157	0.0190	0.0226	0.265	
3	0.0002	0.0009	0.0021	0.038	0.0059	0.0085	0.0115	0.0151	0.0191	0.236	0.285	0.339	0.398	
4	0.0003	0.0013	0.0028	0.050	0.0079	0.0113	0.154	0.201	0.254	0.314	0.380	0.452	0.531	
5	0.0004	0.0016	0.0035	0.063	0.0098	0.141	0.192	0.251	0.318	0.393	0.475	0.570	0.664	
6	0.0005	0.0019	0.0042	0.075	0.0118	0.0170	0.0231	0.0302	0.0382	0.0471	0.0570	0.0679	0.0796	
7	0.0005	0.0022	0.0049	0.088	0.0137	0.0198	0.269	0.352	0.445	0.550	0.665	0.792	0.929	
8	0.0006	0.0025	0.0057	0.101	0.0157	0.226	0.308	0.402	0.509	0.628	0.760	0.905	1.062	
9	0.0007	0.0028	0.0064	0.113	0.0177	0.254	0.346	0.452	0.573	0.707	0.855	1.018	1.195	
10	0.0008	0.0031	0.0071	0.126	0.0196	0.283	0.385	0.503	0.636	0.785	0.950	1.131	1.327	
11	0.0009	0.0035	0.0078	0.138	0.0216	0.0311	0.0423	0.0553	0.0700	0.0864	0.1045	0.1244	0.1460	
12	0.0009	0.0038	0.0085	0.151	0.236	0.339	0.462	0.603	0.763	0.942	1.140	1.357	1.593	
13	0.0010	0.0041	0.0092	0.163	0.255	0.368	0.500	0.653	0.827	1.021	1.235	1.470	1.725	
14	0.0011	0.0044	0.0099	0.176	0.275	0.396	0.539	0.704	0.891	1.100	1.330	1.583	1.858	
15	0.0012	0.0047	0.106	0.188	0.295	0.424	0.577	0.754	0.954	1.178	1.425	1.696	1.991	
16	0.0013	0.0050	0.0113	0.201	0.0314	0.0452	0.0616	0.0804	0.1018	0.1257	0.1521	0.1810	0.2124	
17	0.0013	0.0053	0.0120	0.214	0.334	0.481	0.654	0.855	1.082	1.335	1.616	1.923	2.256	
18	0.0014	0.0057	0.0127	0.226	0.353	0.509	0.693	0.905	1.145	1.414	1.711	2.036	2.389	
19	0.0015	0.0060	0.0134	0.239	0.373	0.537	0.731	0.955	1.209	1.492	1.806	2.149	2.522	
20	0.0016	0.0063	0.0141	0.251	0.393	0.565	0.770	1.005	1.272	1.571	1.901	2.262	2.655	

CUBIC CONTENTS OF CYLINDERS—(Continued).

[Metric System.]

Length, Feet.		Diameter in Centimeters.													Length, Feet.	
14	15	16	17	18	19	20	21	22	23	24	25	26	25	26		
Contents in Cubic Meters.																
1	0.0154	0.0177	0.0201	0.0227	0.0254	0.0284	0.0314	0.0346	0.0380	0.0415	0.0452	0.0491	0.0531	1	0.0531	
2	0.308	0.353	0.402	0.454	0.509	0.567	0.628	0.693	0.760	0.831	0.905	0.981	1.062	2	1.062	
3	0.462	0.530	0.603	0.681	0.763	0.851	0.942	1.039	1.140	1.246	1.357	1.473	1.593	3	1.593	
4	0.616	0.707	0.804	0.908	1.018	1.134	1.257	1.385	1.521	1.662	1.810	1.963	2.124	4	2.124	
5	0.770	0.884	1.005	1.135	1.272	1.418	1.571	1.732	1.901	2.077	2.262	2.454	2.655	5	2.655	
6	0.0924	0.1060	0.1206	0.1362	0.1527	0.1701	0.1885	0.2078	0.2281	0.2493	0.2714	0.2945	0.3186	6	0.3186	
7	1.078	1.237	1.407	1.589	1.781	1.985	2.199	2.425	2.661	2.908	3.167	3.436	3.717	7	3.717	
8	1.232	1.414	1.608	1.816	2.036	2.268	2.513	2.771	3.041	3.324	3.619	3.927	4.247	8	4.247	
9	1.385	1.590	1.810	2.043	2.290	2.552	2.827	3.117	3.421	3.739	4.072	4.418	4.778	9	4.778	
10	1.539	1.767	2.011	2.270	2.545	2.835	3.142	3.464	3.801	4.155	4.524	4.909	5.309	10	5.309	
11	0.1693	0.1944	0.2212	0.2497	0.2799	0.3119	0.3456	0.3810	0.4181	0.4570	0.4976	0.5400	0.5840	11	0.5840	
12	1.847	2.121	2.413	2.724	3.054	3.402	3.770	4.156	4.562	4.986	5.429	5.890	6.371	12	6.371	
13	2.001	2.297	2.614	2.951	3.308	3.686	4.081	4.503	4.942	5.401	5.881	6.381	6.902	13	6.902	
14	2.155	2.474	2.815	3.178	3.563	3.969	4.398	4.849	5.322	5.817	6.333	6.872	7.433	14	7.433	
15	2.309	2.651	3.016	3.405	3.817	4.253	4.712	5.195	5.702	6.232	6.786	7.363	7.964	15	7.964	
16	0.2463	0.2827	0.3217	0.3632	0.4072	0.4536	0.5027	0.5542	0.6082	0.6648	0.7238	0.7854	0.8495	16	0.8495	
17	2.617	3.004	3.418	3.859	4.326	4.820	5.341	5.888	6.462	7.063	7.691	8.345	9.026	17	9.026	
18	2.771	3.181	3.619	4.086	4.580	5.104	5.655	6.234	6.842	7.479	8.143	8.836	9.557	18	9.557	
19	2.925	3.358	3.820	4.313	4.835	5.387	5.969	6.581	7.223	7.894	8.595	9.327	1.0088	19	1.0088	
20	3.079	3.534	4.021	4.540	5.089	5.671	6.283	6.927	7.603	8.310	9.048	9.817	0.619	20	0.619	

CUBIC CONTENTS OF CYLINDERS—(Continued).
[Metric System.]

Length, Feet.	Diameter in Centimeters.																		Length, Feet.
	27	28	29	30	31	32	33	34	35	36	37	38	39						
	Contents in Cubic Meters.																		
1	0.0573	0.0616	0.0661	0.0707	0.0755	0.0804	0.0855	0.0908	0.0962	0.1018	0.1075	0.1134	0.1195	1	0.1195				
2	1145	1232	1321	1414	1510	1608	1711	1816	1924	2036	2150	2268	2389	2	2389				
3	1718	1847	1982	2121	2264	2413	2566	2724	2886	3054	3226	3402	3584	3	3584				
4	2290	2463	2642	2827	3019	3217	3421	3632	3848	4072	4301	4536	4778	4	4778				
5	2863	3079	3303	3534	3774	4021	4276	4540	4811	5089	5376	5671	5973	5	5973				
6	3435	3695	3963	4241	4529	4825	5132	5448	5773	6107	6451	6805	7168	6	7168				
7	4008	4310	4624	4948	5283	5630	5987	6355	6735	7125	7526	7939	8362	7	8362				
8	4580	4926	5284	5655	6038	6434	6842	7263	7697	8143	8602	9073	9557	8	9557				
9	5153	5542	5945	6362	6793	7238	7698	8171	8659	9161	9687	1.0207	1.0751	9	1.0751				
10	5726	6158	6605	7069	7548	8042	8553	9079	9621	1.0179	1.0752	1.1341	1.1946	10	1.1946				
11	6298	6773	7266	7775	8302	8847	9408	9987	1.0583	1.1197	1.1827	1.2475	1.3140	11	1.3140				
12	6871	7389	7926	8482	9057	9651	1.0264	1.0895	1.1545	1.2215	2903	3609	4335	12	4335				
13	7443	8005	8587	9189	9813	1.0455	1.1119	1.1803	2507	3232	3978	4743	5530	13	5530				
14	8016	8621	9247	9896	1.0567	1.259	1974	2711	3470	4250	5053	5878	6724	14	6724				
15	8588	9236	9908	1.0603	1.322	2064	2829	3619	4432	5268	6128	7012	7919	15	7919				
16	9161	0.9852	1.0568	1.1310	1.2076	1.2868	1.3685	1.4527	1.5394	1.6286	1.7203	1.8146	1.9113	16	1.9113				
17	9733	1.0468	1.229	2017	2831	3672	4540	5435	6356	7304	8279	9280	2.0308	17	2.0308				
18	1.0306	1.084	1.886	2723	3586	4476	5395	6343	7318	8322	9354	1.0414	1.903	18	1.903				
19	0.879	1.699	2550	3430	4341	5281	6251	7250	8280	9340	2.0429	1548	2697	19	2697				
20	1.451	2.315	3210	4137	5095	6085	7106	8158	9242	2.0358	1504	2682	3892	20	3892				

CUBIC CONTENTS OF CYLINDERS—(Continued).
[Metric System.]

Length, Feet.	Diameter in Centimeters.										Length, Feet.		
	40	41	42	43	44	45	46	47	48	49		50	51
1	0.1257	0.1320	0.1385	0.1452	0.1521	0.1590	0.1662	0.1735	0.1810	0.1886	0.1963	0.2043	0.2124
2	2513	2641	2771	2904	3041	3181	3324	3470	3619	3771	3927	4086	4247
3	3770	3961	4156	4356	4562	4771	4986	5205	5429	5657	5890	6128	6371
4	5027	5281	5542	5808	6082	6362	6648	6940	7238	7543	7854	8171	8495
5	6283	6601	6927	7261	7603	7952	8310	8675	9048	9429	9817	1.0214	1.0619
6	0.7540	0.7922	0.8313	0.8713	0.9123	0.9543	0.9971	1.0410	1.0857	1.1314	1.1781	1.2257	1.2742
7	8796	9242	9698	1.0165	1.0644	1.1133	1.1633	2145	2667	3200	3744	4300	4866
8	1.0053	1.0562	1.1084	1.1618	2164	2723	3295	3880	4476	5086	5708	6343	6990
9	1.310	1882	2469	3070	3685	4314	4957	5614	6286	6972	7671	8385	9113
10	2506	3203	3854	4522	5205	5904	6619	7349	8096	8857	9635	2.0428	2.1237
11	1.3823	1.4523	1.5240	1.5974	1.6726	1.7495	1.8281	1.9084	1.9905	2.0743	2.1598	2.2471	2.3361
12	5080	5813	6625	7426	8246	9085	9943	2.0819	2.1715	2629	3562	4514	5485
13	6336	7163	8011	8879	9767	2.0676	2.1605	2554	3524	4515	5525	6557	7608
14	7593	8484	9396	2.0331	2.1287	2266	3267	4289	5334	6400	7489	8599	9732
15	8850	9804	2.0782	1783	2868	3856	4929	6024	7143	8286	9452	3.0642	3.1856
16	2.0106	2.1124	2.2167	2.3235	2.4328	2.5447	2.6590	2.7759	2.8953	3.0172	3.1416	3.2685	3.3979
17	1363	2444	3553	4687	5849	7037	8252	9494	3.0762	2058	3379	4728	6103
18	2619	3765	4938	6140	7370	8628	9914	3.1229	2572	3943	5343	6771	8227
19	3876	5085	6323	7592	8890	3.0218	3.1576	2964	4382	5829	7306	8814	4.0351
20	5133	6405	7709	9044	3.0411	1809	3238	4699	6191	7715	9270	4.0856	2474

CUBIC CONTENTS OF CYLINDERS—(Continued).
[Metric System.]

Length, Feet.	Diameter in Centimeters.															Length, Feet.
	53	54	55	56	57	58	59	60	61	62	63	64	65			
	Contents in Cubic Meters.															
1	0.2206	0.2290	0.2376	0.2463	0.2552	0.2642	0.2734	0.2827	0.2922	0.3019	0.3117	0.3217	0.3318	1		
2	4412	4580	4752	4926	5104	5284	5468	5655	5845	6038	6234	6434	6637	2		
3	6619	6871	7127	7389	7655	7926	8202	8482	8767	9057	9352	9651	9955	3		
4	8825	9161	9503	9852	1.0207	1.0568	1.0936	1.1310	1.1690	1.2076	1.2469	1.2868	1.3273	4		
5	1.1031	1.1451	1.1879	1.2315	1.2759	3.210	3670	4137	4612	5095	5586	6085	6592	5		
6	1.3237	1.3741	1.4255	1.4778	1.5311	1.5852	1.6404	1.6965	1.7535	1.8114	1.8703	1.9302	1.9910	6		
7	5443	6032	6631	7241	7862	8495	9138	9792	2.0457	2.1133	2.1821	2.2519	2.3228	7		
8	7649	8322	9007	9704	2.0414	2.1137	2.1872	2.2619	3380	4153	4938	5736	6546	8		
9	9856	2.0613	2.1382	2.2167	2966	3779	4606	5447	6302	7172	8055	8953	9865	9		
10	2.2062	2902	3758	4630	5518	6421	7340	8274	9225	3.0191	3.1172	3.2170	3.3183	10		
11	4.268	2.5192	2.6134	2.7093	2.8069	2.9063	3.0074	3.1102	3.2147	3.3210	3.4290	3.5387	3.6501	11		
12	6474	7483	8510	9556	3.0621	3.1705	2808	3929	5070	6229	7407	8604	9820	12		
13	8680	9773	3.0886	3.2019	3173	4347	5542	6757	7992	9248	4.0524	4.1821	4.3138	13		
14	3.0887	3.2063	3262	4482	5725	6989	8276	9584	4.0915	4.2267	3641	5038	6456	14		
15	3993	4353	5637	6945	8276	9631	4.1010	4.2411	3837	5286	6759	8255	9775	15		
16	3.5299	3.6644	3.8013	3.9408	4.0828	4.2273	4.3744	4.5239	4.6759	4.8305	4.9876	5.1472	5.3093	16		
17	7595	8934	4.0389	4.1871	3380	4915	6478	8066	9682	5.1324	5.2993	4689	6411	17		
18	9711	4.1224	2765	4334	5932	7557	9211	5.0894	5.2604	4343	6110	7906	9730	18		
19	4.1917	3514	5141	6797	8483	5.0200	5.1945	3721	5527	7362	9228	6.1123	6.3048	19		
20	4124	5804	7517	9260	5.1035	2842	4679	6549	8449	6.0381	6.2345	4340	6366	20		

CUBIC CONTENTS OF CYLINDERS—(Continued).
[Metric System.]

Length, Feet.	Diameter in Centimeters.																			Length, Feet.
	66	67	68	69	70	71	72	73	74	75	76	77	78							
	Contents in Cubic Meters.																			
1	0.3421	0.3526	0.3632	0.3739	0.3848	0.3959	0.4072	0.4185	0.4301	0.4418	0.4536	0.4657	0.4778	1	0.4778					
2	6842	7051	7263	7479	7697	7918	8143	8371	8602	8836	9073	9313	9557	2	9557					
3	1.0204	1.0577	1.0895	1.1218	1.1545	1.1878	1.2215	1.2556	1.2903	1.3254	1.3609	1.3970	1.4335	3	1.4335					
4	3685	4103	4527	4957	5394	5837	6286	6742	7203	7671	8146	8627	9113	4	9113					
5	7106	7628	8158	8696	9242	9796	2.0358	2.0927	2.1504	2.2089	2.2682	2.3283	2.3892	5	2.3892					
6	2.0527	2.1154	2.1790	2.2436	2.3091	2.3755	2.4429	2.5112	2.5805	2.6507	2.7219	2.7940	2.8670	6	2.8670					
7	3948	4680	5422	6175	6939	7714	8501	9298	3.0106	3.0925	3.1755	3.2596	3.3449	7	3.3449					
8	7370	8205	9053	9914	3.0788	3.1674	3.2572	3.3483	4407	5343	6292	7253	8227	8	8227					
9	3.0791	3.1731	3.2685	3.3654	4636	5633	6644	7668	8708	9761	4.0828	4.1910	4.3005	9	4.3005					
10	4212	5257	6317	7393	8485	9592	4.0715	4.1854	4.3008	4.4179	5365	6566	7784	10	7784					
11	3.7633	3.8782	3.9948	4.1132	4.2333	4.3551	4.4787	4.6039	4.7309	4.8597	4.9901	5.1223	5.2562	11	5.2562					
12	4.1054	4.2308	4.3580	4.4871	6181	7510	8858	5.0225	5.1610	5.3014	5.4438	5880	7340	12	7340					
13	4476	5833	7212	8611	5.0030	5.1469	5.2930	4410	5911	7432	8974	6.0536	6.2119	13	6.2119					
14	7897	9359	5.0844	5.2350	3878	5429	7001	8595	6.0212	6.1850	6.3510	5193	6897	14	6897					
15	5.1318	5.2885	4475	6089	7727	9388	6.1073	6.2781	4513	6268	8047	9849	7.1675	15	7.1675					
16	5.4739	5.6410	5.8107	5.9828	6.1575	6.3347	6.5144	6.6966	6.8813	7.0686	7.2583	7.4506	7.6454	16	7.6454					
17	8160	9936	5.4739	6.3568	5424	7306	9216	7.1152	7.3114	5104	7120	9163	8.1232	17	8.1232					
18	6.1581	5.3462	5370	7307	9272	7.1265	7.3287	5337	7415	9522	8.1656	8.3819	6011	18	6011					
19	5003	6987	9002	7.1046	7.3121	5225	7359	9522	8.1716	8.3939	6193	8476	9.0789	19	9.0789					
20	8424	7.0513	7.2634	4786	6969	9184	8.1430	8.3708	6017	8357	9.0729	9.3133	5567	20	5567					

CUBIC CONTENTS OF CYLINDERS—(Continued).
[Metric System.]

Length, Feet.	Diameter in Centimeters.																				Length Feet.
	79	80	81	82	83	84	85	86	87	88	89	90									
Contents in Cubic Meters.																					
1	0.4902	0.5027	0.5153	0.5281	0.5411	0.5542	0.5675	0.5809	0.5945	0.6082	0.6221	0.6362	1	0.6362							
2	9803	1.0053	1.0306	1.0562	1.0821	1.1084	1.1349	1.1618	1.1889	1.2164	1.2442	1.2723	2	1.2723							
3	1.4705	5080	5159	5843	6232	6625	7024	7426	7834	8246	8663	9085	3	9085							
4	9607	2.0106	2.0612	2.1124	2.1642	2.2167	2.2698	2.3235	2.3779	2.4328	2.4885	2.5447	4	2.5447							
5	2.4508	5133	5765	6405	7053	7709	8373	9044	9723	3.0411	3.1106	3.1809	5	3.1809							
6	2.9410	3.0159	3.0918	3.1686	3.2464	3.3251	3.4047	3.4853	3.5668	3.6493	3.7327	3.8170	6	3.8170							
7	3.4312	5186	6071	6967	7874	8792	9722	4.0662	4.1613	4.2575	4.3548	4.4532	7	4.4532							
8	9213	4.0212	4.1224	4.2248	4.3285	4.4334	4.5396	6470	7557	8657	9769	5.0804	8	5.0804							
9	4.4115	5239	6377	7529	8695	9876	5.1071	5.2279	5.3502	5.4739	5.5990	7256	9	7256							
10	9017	5.0265	5.1530	5.2810	5.4106	5.5418	6745	8088	9447	6.0821	6.2211	6.3617	10	6.3617							
11	5.3918	5.5292	5.6683	5.8091	5.9517	6.0959	6.2420	6.3897	6.5391	6.6903	6.8433	6.9979	11	6.9979							
12	8820	6.0319	6.1836	6.3372	6.4927	6.6501	8094	9706	7.1336	7.2985	7.4654	7.6341	12	7.6341							
13	5.3722	5345	6989	8653	7.033	7.2043	7.3769	7.5514	7281	9068	8.0875	8.2702	13	8.2702							
14	8623	7.0372	7.2142	7.3934	7.5749	7.7585	9443	8.1323	8.3226	8.5150	7096	9064	14	9064							
15	7.3525	5397	7295	9215	8.1155	8.3126	8.5118	7132	9170	9.1232	9.3317	9.5426	15	9.5426							
16	8427	8.0425	8.2448	8.4496	6570	8.8668	9.0792	9.2941	9.5115	9.7314	9.9538	10.1788	16	10.1788							
17	8.3328	5451	7601	9777	9.1980	9.4210	6467	8750	10.1060	10.3396	10.5759	8149	17	8149							
18	8230	9.0478	9.2754	9.5058	7391	9752	10.2141	10.4558	7004	9478	11.1980	11.4511	18	11.4511							
19	9.3132	5504	9707	10.0339	10.280	10.5294	7816	11.0367	11.2949	11.5560	8202	12.0873	19	12.0873							
20	8033	10.0531	10.3060	5020	821	1.0835	11.3490	6176	8804	12.1642	12.4423	7235	20	7235							

CUBIC CONTENTS OF CYLINDERS—(Continued)
[Metric System.]

Length, Feet.	Diameter in Centimeters.										Length, Feet.
	91	92	93	94	95	96	97	98	99	100	
	Contents in Cubic Feet.										
1	0.6504	0.6648	0.6793	0.6940	0.7088	0.7238	0.7390	0.7543	0.7698	0.7854	1
2	1.3008	1.3295	1.3586	1.3880	1.4176	1.4476	1.4780	1.5086	1.5395	1.5708	2
3	9512	9943	2.0379	2.0819	2.1265	2.1715	2.2169	2.2629	2.3093	2.3562	3
4	2.6016	2.6590	7172	7759	8353	8953	9559	3.0172	3.0791	3.1416	4
5	3.2519	3.3238	3.3965	3.4699	3.5441	3.6191	3.6949	7715	8488	9270	5
6	3.9023	3.9886	4.0757	4.1639	4.2529	4.3429	4.4339	4.5258	4.6186	4.7124	6
7	4.5527	4.6533	7550	8578	9618	5.0668	5.1729	5.2801	5.3884	5.4978	7
8	5.2031	5.3181	5.4343	5.5518	5.6706	7906	9118	6.0344	6.1581	6.2832	8
9	5.8535	5.9828	6.1136	6.2458	6.3794	6.5144	6.6508	7887	9279	7.0686	9
10	6.5039	6.6476	7929	9398	7.0882	7.2382	7.3898	7.5430	7.6977	8540	10
11	7.1543	7.3124	7.4722	7.6338	7.7970	7.9621	8.1288	8.2973	8.4675	8.6394	11
12	8047	9771	8.1515	8.3277	8.5059	8.6859	8.8678	9.0516	9.2372	9.4248	12
13	8.4550	8.6419	8308	9.0217	9.2147	9.4097	9.6068	8058	10.0070	0.2102	13
14	9.1051	9.3067	9.5101	7157	9235	10.1335	10.3457	10.5601	7768	9956	14
15	7558	9714	10.1894	10.4097	10.6323	8573	11.0847	11.3144	11.5465	11.7810	15
16	10.4062	10.6362	10.8687	11.1036	11.3411	11.5812	11.8237	12.0687	12.3163	12.5664	16
17	11.0566	11.3009	11.5479	7976	12.0500	12.3050	12.5627	8230	13.0861	13.3518	17
18	7070	9657	12.2272	12.4916	7588	13.0288	13.3017	13.5773	8558	14.1372	18
19	12.3574	12.6305	9065	13.1856	13.4676	7526	14.0406	14.3316	14.6256	9226	19
20	13.0078	13.2952	13.5858	8796	14.1764	14.4765	7796	15.0859	15.3954	15.7080	20

ROUND TIMBER REDUCED TO SQUARE TIMBER.
TWO-THIRDS RULE.

Length, Feet.	Average Diameter in Inches.																						Length, Feet.
	6	7	8	9	10	11	12	13	14	15	16	17	18	19	20	21	22						
	Contents in Cubic Feet.																						
10	1.0	1.5	2.0	2.5	3.1	3.7	4.5	5.2	6.1	6.9	7.9	8.7	10.0	11.1	12.3	13.6	14.9	10					
12	1.2	1.8	2.4	3.0	3.7	4.5	5.4	6.3	7.3	8.3	9.5	10.5	12.0	13.4	14.8	16.3	17.9	12					
14	1.4	2.1	2.8	3.5	4.3	5.2	6.2	7.3	8.5	9.7	11.0	12.2	14.0	15.6	17.3	19.1	20.9	14					
16	1.6	2.4	3.2	4.0	4.9	6.0	7.1	8.3	9.7	11.1	12.6	13.9	16.0	17.8	19.7	21.8	23.9	16					
18	1.8	2.7	3.6	4.5	5.5	6.7	8.0	9.4	10.9	12.5	14.2	15.7	18.0	20.0	22.2	24.5	26.9	18					
20	2.0	3.0	3.9	5.0	6.2	7.5	8.9	10.4	12.1	13.9	15.8	17.4	20.0	22.3	24.7	27.2	29.9	20					
22	2.2	3.3	4.3	5.5	6.8	8.2	9.8	11.5	13.3	15.3	17.4	19.2	22.0	24.5	27.1	29.9	32.8	22					
24	2.4	3.6	4.7	6.0	7.4	9.0	10.7	12.5	14.5	16.7	18.9	20.9	24.0	26.7	29.6	32.7	35.8	24					
26	2.6	3.9	5.1	6.5	8.0	9.7	11.6	13.5	15.7	18.0	20.5	22.6	26.0	28.9	32.1	35.4	38.8	26					
28	2.8	4.2	5.5	7.0	8.6	10.4	12.5	14.6	16.9	19.4	22.1	24.4	28.0	31.2	34.6	38.1	41.8	28					
30	3.0	4.5	5.9	7.5	9.2	11.2	13.4	15.6	18.2	20.8	23.7	26.1	30.0	33.4	37.0	40.8	44.8	30					
32	3.2	4.8	6.3	8.0	9.9	11.9	14.3	16.7	19.4	22.2	25.2	27.9	32.0	35.6	39.5	43.6	47.8	32					
34	3.4	5.1	6.7	8.5	10.5	12.7	15.2	17.7	20.6	23.6	26.8	29.6	34.0	37.8	42.0	46.3	50.8	34					
36	3.6	5.4	7.1	9.0	11.1	13.4	16.1	18.8	21.8	25.0	28.4	31.4	36.0	40.1	44.4	49.0	53.7	36					
38	3.8	5.7	7.5	9.5	11.7	14.2	16.9	19.8	23.0	26.4	30.0	33.1	38.0	42.3	46.9	51.7	56.7	38					
40	4.0	6.0	7.9	10.0	12.3	14.9	17.8	20.8	24.2	27.8	31.6	34.8	40.0	44.5	49.4	54.4	59.7	40					
42	4.2	6.3	8.3	10.5	12.9	15.7	18.7	21.9	25.4	29.1	33.1	36.6	42.0	46.7	51.8	57.2	62.7	42					
44	4.4	6.6	8.7	11.0	13.6	16.4	19.6	22.9	26.6	30.5	34.7	38.3	44.0	49.0	54.3	59.9	65.7	44					
46	4.6	6.9	9.1	11.5	14.2	17.2	20.5	24.0	27.8	31.9	36.3	40.1	46.0	51.2	56.8	62.6	68.7	46					
48	4.8	7.2	9.6	12.0	14.8	17.9	21.4	25.0	29.0	33.3	37.9	41.8	48.0	53.4	59.2	65.3	71.7	48					
50	5.0	7.5	9.9	12.5	15.4	18.7	22.3	26.1	30.1	34.7	39.5	43.6	50.0	55.7	61.7	68.1	74.7	50					
52	5.2	7.9	10.2	13.0	16.0	19.4	23.2	27.1	31.5	36.1	41.0	45.3	52.0	57.9	64.2	70.8	77.6	52					
54	5.4	8.2	10.6	13.5	16.6	20.1	24.1	28.1	32.7	37.5	42.6	47.0	54.0	60.1	66.6	73.5	80.6	54					
56	5.6	8.5	11.0	14.0	17.2	20.9	25.0	29.2	33.9	38.9	44.2	48.8	56.0	62.3	69.1	76.2	83.6	56					
58	5.8	8.8	11.4	14.5	17.9	21.6	25.9	30.2	35.1	40.3	45.8	50.5	58.0	64.6	71.6	78.9	86.6	58					
60	6.1	9.1	11.8	15.0	18.5	22.4	26.7	31.3	36.3	41.6	47.3	52.3	60.0	66.8	74.0	81.7	89.6	60					
70	7.1	10.6	13.8	17.5	21.6	26.1	31.2	36.5	42.4	48.6	55.2	61.0	70.0	77.9	86.4	95.3	104.5	70					

ROUND TIMBER REDUCED TO SQUARE TIMBER—(Continued).
TWO-THIRDS RULE.

Length, Feet.	Average Diameter in Inches.														Length, Feet.
	23	24	25	26	27	28	29	30	31	32	33	34	35	36	
	Contents in Cubic Feet.														
10	16.3	17.8	19.3	20.9	22.5	24.2	26.0	27.8	29.7	31.6	33.6	35.7	37.8	40.0	10
12	19.6	21.3	23.1	25.0	27.0	29.0	31.1	33.3	35.6	38.0	40.3	42.8	45.3	48.0	12
14	22.9	24.9	27.0	29.2	31.5	33.9	36.3	38.9	41.5	44.3	47.0	49.9	52.9	56.0	14
16	26.1	28.4	30.8	33.4	36.0	38.7	41.5	44.4	47.4	50.6	53.8	57.0	60.5	64.0	16
18	29.4	32.0	34.7	37.5	40.5	43.5	46.7	50.0	53.4	57.0	60.5	64.2	68.0	72.0	18
20	32.7	35.5	38.5	41.7	45.0	48.4	51.9	55.5	59.3	63.3	67.2	71.3	75.6	80.0	20
22	35.9	39.1	42.4	45.9	49.5	53.2	57.1	61.1	65.2	69.6	73.9	78.4	83.1	88.0	22
24	39.2	42.6	46.2	50.0	54.0	58.0	62.3	66.6	71.2	75.9	80.6	85.6	90.7	96.0	24
26	42.5	46.2	50.1	54.2	58.5	62.9	67.5	72.2	77.1	82.3	87.4	92.7	98.2	104.0	26
28	45.7	49.7	54.0	58.4	63.0	67.7	72.7	77.7	83.0	88.6	94.1	99.8	105.8	112.0	28
30	49.0	53.3	57.8	62.6	67.5	72.5	77.9	83.3	89.0	94.9	100.8	107.0	113.4	120.0	30
32	52.3	56.8	61.7	66.7	72.0	77.4	83.0	88.8	94.9	101.2	107.5	114.1	120.9	128.0	32
34	55.5	60.4	65.5	70.9	76.5	82.2	88.2	94.4	100.8	107.6	114.2	121.2	128.5	136.0	34
36	58.8	63.9	69.4	75.1	81.0	87.0	93.4	99.9	106.7	113.9	121.0	128.3	136.0	144.0	36
38	62.1	67.5	73.2	79.2	85.5	91.9	98.6	105.5	112.7	120.2	127.7	135.5	143.6	152.0	38
40	65.3	71.0	77.1	83.4	90.0	96.7	103.8	111.0	118.6	126.6	134.4	142.6	151.2	160.0	40
42	68.6	74.6	80.9	87.6	94.5	101.6	109.0	116.6	124.5	132.9	141.1	149.7	158.7	168.0	42
44	71.9	78.1	84.8	91.7	99.0	106.4	114.2	122.1	130.5	139.2	147.8	156.9	166.3	176.0	44
46	75.1	81.7	88.6	95.9	103.5	111.2	119.4	127.7	136.4	145.5	154.6	164.0	173.8	184.0	46
48	78.4	85.2	92.5	100.1	108.0	116.1	124.3	132.8	142.3	151.9	161.3	171.1	181.4	192.0	48
50	81.7	88.8	96.4	104.3	112.5	120.9	129.8	138.8	148.3	158.2	168.0	178.3	189.0	200.0	50
52	84.9	92.4	100.2	108.4	117.0	125.7	134.9	144.4	154.2	164.5	174.7	185.4	196.5	208.0	52
54	88.2	95.9	104.1	112.6	121.5	130.6	140.1	149.9	160.1	170.9	181.4	192.5	204.1	216.0	54
56	91.4	99.5	107.9	116.8	126.0	135.4	145.3	155.5	166.0	177.2	188.2	199.6	211.6	224.0	56
58	94.7	103.0	111.8	120.9	130.5	140.2	150.5	161.0	172.0	183.5	194.9	206.8	219.2	232.0	58
60	98.0	106.6	115.6	125.1	135.0	145.1	155.7	166.6	177.9	189.8	201.6	213.9	226.7	240.0	60
70	114.3	124.3	134.9	146.0	157.5	169.3	181.7	194.3	207.6	221.5	235.2	249.6	264.5	280.0	70

ROUND TIMBER REDUCED TO SQUARE TIMBER.
INSCRIBED SQUARE RULE.

Length, Feet.	Average Diameter in Inches.														Length, Feet.		
	6	7	8	9	10	11	12	13	14	15	16	17	18	19		20	21
Contents in Cubic Feet.																	
10	1.3	1.7	2.2	2.8	3.5	4.2	5.0	5.9	6.8	7.8	8.9	10.0	11.3	12.5	13.9	15.3	16.8
12	1.5	2.0	2.7	3.4	4.2	5.0	6.0	7.0	8.2	8.8	10.7	12.0	13.5	15.0	16.7	18.4	20.1
14	1.8	2.4	3.1	3.9	4.9	5.9	7.0	8.2	9.5	10.2	12.4	14.1	15.8	17.5	19.4	21.4	23.5
16	2.0	2.7	3.6	4.5	5.6	6.7	8.0	9.4	10.9	11.7	14.2	16.1	18.0	20.0	22.2	24.5	26.9
18	2.3	3.0	4.0	5.1	6.2	7.6	9.0	10.5	12.3	13.2	16.0	18.1	20.3	22.6	25.0	27.6	30.2
20	2.5	3.4	4.4	5.6	7.0	8.4	10.0	11.7	13.6	14.6	17.8	20.1	22.5	25.1	27.8	30.6	33.6
22	2.8	3.7	4.9	6.2	7.6	9.2	11.0	12.9	15.0	16.1	19.5	22.1	24.8	27.6	30.1	33.7	37.0
24	3.0	4.0	5.3	6.7	8.3	10.1	12.0	14.1	16.3	17.5	21.3	24.1	27.0	30.1	33.3	36.7	40.3
26	3.3	4.4	5.8	7.3	9.0	11.0	13.0	15.3	17.7	19.0	23.1	26.1	29.3	32.6	36.1	39.8	43.7
28	3.5	4.7	6.2	7.9	9.7	11.8	14.0	16.4	19.1	20.5	24.9	28.1	31.5	35.1	38.9	42.9	47.0
30	3.8	5.0	6.7	8.4	10.4	12.6	15.0	17.6	20.4	22.0	26.6	30.1	33.8	37.6	41.7	45.9	50.4
32	4.0	5.4	7.1	9.0	11.1	13.4	16.0	18.8	21.8	23.4	28.4	32.1	36.0	40.1	44.4	49.0	53.8
34	4.3	5.7	7.5	9.6	11.8	14.3	17.0	19.9	23.2	24.9	30.2	34.1	38.3	42.6	47.2	52.1	57.1
36	4.5	6.0	8.0	10.1	12.5	15.1	18.0	20.9	24.5	26.3	32.0	36.1	40.2	45.1	50.0	55.1	60.5
38	4.8	6.4	8.4	10.7	13.2	16.0	19.0	22.7	25.9	27.8	33.7	38.2	42.8	47.6	52.8	58.2	63.8
40	5.0	6.7	8.9	11.2	13.9	16.8	20.0	23.4	27.2	29.2	35.6	40.2	45.0	50.1	55.6	61.2	67.2
42	5.3	7.1	9.3	11.8	14.6	17.6	21.0	24.6	28.6	30.7	37.3	42.2	47.3	52.6	58.3	64.3	70.6
44	5.5	7.4	9.8	12.4	15.3	18.5	22.0	25.8	30.0	32.2	39.1	44.2	49.5	55.1	61.1	67.4	73.9
46	5.8	7.7	10.2	12.9	16.0	19.3	23.0	27.0	31.3	33.6	40.8	46.2	51.8	57.6	63.9	70.4	77.3
48	6.0	8.1	10.7	13.5	16.6	20.2	24.0	28.1	32.7	35.1	42.6	48.2	54.0	60.1	66.7	73.5	80.6
50	6.3	8.4	11.1	14.1	17.4	21.0	25.0	29.3	34.1	36.6	44.4	50.2	56.3	62.7	69.5	76.6	84.0
52	6.5	8.7	11.5	14.6	18.0	21.8	26.0	30.5	35.4	38.0	46.2	52.2	58.5	65.2	72.2	79.6	87.4
54	6.8	9.1	12.0	15.2	18.7	22.7	27.0	31.6	36.8	39.5	48.0	54.2	60.8	67.7	75.0	82.7	90.7
56	7.0	9.4	12.4	15.7	19.4	23.5	28.0	32.8	38.1	41.0	49.7	56.2	63.0	70.2	77.8	85.7	94.1
58	7.3	9.7	12.9	16.3	20.1	24.4	29.0	34.1	39.5	42.4	51.5	58.2	65.3	72.7	80.6	88.8	97.4
60	7.5	10.1	13.3	16.9	20.8	25.2	30.0	35.2	40.9	43.9	53.3	60.2	67.5	75.2	83.3	91.9	100.8
70	8.8	11.8	15.5	19.7	24.3	29.4	35.0	41.0	47.7	51.2	62.2	70.3	78.8	87.7	97.2	107.2	117.6

ROUND TIMBER REDUCED TO SQUARE TIMBER—(Continued).

INSCRIBED SQUARE RULE.

Length, Feet.	Average Diameter in Inches.																Length, Feet.
	23	24	25	26	27	28	29	30	31	32	33	34	35	36			
Contents in Cubic Feet.																	
10	18.4	20.0	21.7	23.5	25.3	27.2	29.2	31.8	33.4	35.5	37.8	40.1	42.5	45.0	10		
12	22.0	24.0	26.0	28.2	30.4	32.7	35.1	38.1	40.0	42.6	45.4	48.2	51.0	54.0	12		
14	25.7	28.0	30.4	32.9	35.4	38.1	40.9	44.5	46.7	49.8	52.9	56.2	59.6	63.0	14		
16	29.4	32.0	34.7	37.6	40.5	43.5	46.7	50.8	53.4	56.9	60.5	64.2	68.1	72.0	16		
18	33.1	36.0	39.0	42.3	45.6	49.0	52.6	57.2	60.0	64.0	68.1	72.2	76.6	81.0	18		
20	36.7	40.0	43.4	47.0	50.6	54.4	58.4	63.5	66.7	71.1	75.6	80.3	85.1	90.0	20		
22	40.4	44.0	47.7	51.7	55.7	59.9	64.3	69.9	73.4	78.2	83.2	88.3	93.6	99.0	22		
24	44.1	48.0	52.1	56.4	60.7	65.3	70.1	76.2	80.1	85.3	90.8	96.3	102.1	108.0	24		
26	47.8	52.0	56.4	61.1	65.8	70.7	75.9	82.6	86.7	92.4	98.3	104.3	110.6	117.0	26		
28	51.4	56.0	60.7	65.8	70.9	76.2	81.8	88.9	93.4	99.5	105.9	112.4	119.1	126.0	28		
30	55.1	60.0	65.1	70.5	75.9	81.6	87.6	95.3	100.0	106.6	113.5	120.4	127.6	135.0	30		
32	58.8	64.0	69.4	75.2	81.0	87.1	93.5	101.6	106.8	113.7	121.0	128.4	136.1	144.0	32		
34	62.5	68.0	73.7	79.9	86.1	92.5	99.3	108.0	113.4	120.8	128.6	136.4	144.6	153.0	34		
36	66.1	72.0	78.1	84.6	91.1	98.0	105.2	114.3	120.1	127.9	136.2	144.5	153.1	162.0	36		
38	69.8	76.0	82.4	89.3	96.2	103.4	111.0	120.7	126.7	135.1	143.7	152.5	161.7	171.0	38		
40	73.5	80.0	86.8	94.0	101.2	108.8	116.8	127.0	133.4	142.2	151.3	160.5	170.2	180.0	40		
42	77.2	84.0	91.1	98.7	106.3	114.3	122.7	133.4	140.1	149.3	158.8	168.5	178.7	189.0	42		
44	80.8	88.0	95.4	103.4	111.4	119.7	128.5	139.7	146.8	156.4	166.4	176.6	187.2	198.0	44		
46	84.5	92.0	99.8	108.1	116.4	125.2	134.4	146.1	153.5	163.5	174.0	184.6	195.7	207.0	46		
48	88.2	96.0	104.1	112.8	121.5	130.6	140.2	152.4	160.1	170.6	181.5	192.6	204.2	216.0	48		
50	91.9	100.0	108.5	117.5	126.6	136.1	146.1	158.8	166.8	177.7	189.1	200.7	212.7	225.0	50		
52	95.5	104.0	112.8	122.1	131.6	141.5	151.9	165.1	173.5	184.8	196.7	208.7	221.2	234.0	52		
54	99.2	108.0	117.1	126.8	136.7	146.9	157.7	171.2	180.1	191.9	204.2	216.7	229.7	243.0	54		
56	102.9	112.0	121.5	131.5	141.7	152.4	163.6	177.8	186.8	199.0	211.8	224.7	238.2	252.0	56		
58	106.5	116.0	125.8	136.2	146.8	157.8	169.4	184.2	193.5	206.1	219.4	232.8	246.7	261.0	58		
60	110.2	120.0	130.1	140.9	151.9	163.3	175.3	190.5	200.2	213.2	226.9	240.8	255.2	270.0	60		
70	128.6	140.0	151.8	164.4	177.2	190.5	204.5	222.3	233.5	248.8	264.7	280.9	297.8	315.0	70		

THE NINETEEN-INCH STANDARD RULE.
BASED ON THIRTEEN-FOOT LOGS.

Length, Feet.	Diameter in Inches.																			Length, Feet.
	4	5	6	7	8	9	10	11	12	13	14	15	16	17	18	19	20			
10	0.03	0.05	0.08	0.11	0.14	0.17	0.21	0.26	0.31	0.36	0.42	0.48	0.55	0.62	0.69	0.77	0.85	10		
11	.03	.06	.08	.12	.15	.19	.23	.28	.34	.40	.46	.53	.60	.68	.76	.85	.94	11		
12	.04	.06	.09	.13	.17	.20	.26	.31	.37	.43	.50	.58	.65	.74	.83	.92	1.02	12		
13	.04	.07	.10	.14	.18	.22	.28	.34	.40	.47	.54	.62	.71	.80	.90	1.00	1.11	13		
14	.04	.08	.11	.15	.19	.24	.30	.36	.43	.50	.58	.67	.76	.86	.97	1.08	1.19	14		
15	.05	.08	.12	.16	.21	.25	.32	.39	.46	.54	.63	.72	.82	.92	1.04	1.15	1.28	15		
16	.05	.09	.12	.17	.22	.27	.34	.41	.49	.58	.67	.77	.87	.99	1.10	1.23	1.36	16		
17	.05	.09	.13	.18	.24	.29	.36	.44	.52	.61	.71	.81	.93	1.05	1.17	1.31	1.45	17		
18	.06	.10	.14	.19	.25	.30	.38	.46	.55	.65	.75	.86	.98	1.11	1.24	1.38	1.53	18		
19	.06	.10	.15	.20	.26	.32	.40	.49	.58	.68	.79	.91	1.04	1.17	1.31	1.46	1.62	19		
20	.06	.11	.15	.22	.28	.34	.43	.52	.61	.72	.84	.96	1.09	1.23	1.38	1.54	1.70	20		
21	.06	.11	.16	.23	.29	.36	.45	.54	.64	.76	.88	1.01	1.15	1.29	1.45	1.62	1.79	21		
22	.07	.12	.17	.24	.31	.37	.47	.57	.67	.79	.92	1.05	1.20	1.35	1.52	1.69	1.88	22		
23	.07	.12	.18	.25	.32	.39	.49	.59	.71	.83	.96	1.10	1.25	1.42	1.59	1.77	1.96	23		
24	.07	.13	.18	.26	.33	.41	.51	.62	.74	.86	1.00	1.15	1.31	1.48	1.66	1.85	2.05	24		
25	.08	.13	.19	.27	.35	.42	.53	.65	.77	.90	1.04	1.20	1.36	1.54	1.73	1.92	2.13	25		
26	.08	.14	.20	.28	.36	.44	.55	.67	.80	.94	1.09	1.25	1.42	1.60	1.80	2.00	2.23	26		
27	.08	.15	.21	.29	.37	.46	.58	.70	.83	.97	1.13	1.29	1.47	1.66	1.86	2.08	2.30	27		
28	.09	.15	.22	.31	.39	.49	.60	.72	.86	1.01	1.17	1.34	1.53	1.72	1.93	2.15	2.39	28		
29	.09	.16	.22	.31	.40	.49	.62	.75	.89	1.04	1.21	1.39	1.58	1.79	2.00	2.23	2.47	29		
30	.09	.16	.23	.32	.42	.51	.64	.77	.92	1.08	1.25	1.44	1.64	1.85	2.07	2.31	2.56	30		

THE NINETEEN-INCH STANDARD RULE—(Continued)
 BASED ON THIRTEEN-FOOT LOGS.

Length, Feet.		Diameter in Inches.																Length Feet.
		21	22	23	24	25	26	27	28	29	30	31	32	33	34	35	36	
Contents in Standards.																		
10	0.94	1.03	1.13	1.23	1.33	1.44	1.55	1.67	1.79	1.92	2.05	2.16	2.32	2.46	2.61	2.76	10	
11	1.03	1.13	1.24	1.35	1.46	1.58	1.71	1.84	1.97	2.11	2.25	2.40	2.55	2.71	2.87	3.04	11	
12	1.13	1.24	1.35	1.47	1.60	1.73	1.86	2.00	2.15	2.30	2.46	2.62	2.78	2.96	3.13	3.31	12	
13	1.22	1.34	1.47	1.60	1.73	1.87	2.02	2.17	2.33	2.49	2.66	2.84	3.02	3.20	3.39	3.59	13	
14	1.32	1.44	1.58	1.72	1.86	2.02	2.17	2.34	2.51	2.68	2.87	3.05	3.25	3.45	3.65	3.87	14	
15	1.41	1.55	1.69	1.84	2.00	2.16	2.33	2.51	2.69	2.88	3.07	3.27	3.48	3.69	3.92	4.14	15	
16	1.50	1.65	1.80	1.96	2.13	2.30	2.49	2.67	2.87	3.07	3.28	3.49	3.71	3.94	4.18	4.42	16	
17	1.60	1.75	1.92	2.09	2.26	2.45	2.64	2.84	3.05	3.26	3.48	3.71	3.94	4.19	4.44	4.69	17	
18	1.69	1.86	2.03	2.21	2.40	2.59	2.80	3.01	3.23	3.45	3.69	3.93	4.18	4.43	4.70	4.97	18	
19	1.79	1.96	2.14	2.33	2.53	2.74	2.95	3.17	3.40	3.64	3.89	4.15	4.41	4.68	4.96	5.25	19	
20	1.88	2.06	2.25	2.46	2.66	2.88	3.11	3.34	3.58	3.84	4.10	4.36	4.64	4.93	5.22	5.52	20	
21	1.97	2.17	2.37	2.58	2.80	3.02	3.26	3.51	3.76	4.03	4.30	4.58	4.87	5.17	5.48	5.80	21	
22	2.07	2.27	2.48	2.70	2.93	3.17	3.42	3.68	3.94	4.22	4.51	4.80	5.10	5.42	5.74	6.08	22	
23	2.16	2.37	2.59	2.82	3.06	3.31	3.57	3.84	4.12	4.41	4.71	5.02	5.34	5.66	6.00	6.35	23	
24	2.26	2.48	2.71	2.95	3.20	3.46	3.73	4.01	4.30	4.60	4.91	5.24	5.57	5.91	6.26	6.63	24	
25	2.35	2.58	2.82	3.07	3.33	3.60	3.88	4.18	4.48	4.79	5.12	5.45	5.80	6.16	6.53	6.90	25	
26	2.44	2.68	2.93	3.19	3.46	3.75	4.04	4.34	4.66	4.99	5.32	5.67	6.03	6.40	6.79	7.18	26	
27	2.54	2.78	3.04	3.31	3.60	3.89	4.19	4.51	4.84	5.18	5.53	5.89	6.27	6.65	7.05	7.46	27	
28	2.63	2.89	3.16	3.44	3.73	4.03	4.35	4.68	5.02	5.37	5.73	6.11	6.50	6.90	7.31	7.73	28	
29	2.73	2.99	3.27	3.56	3.86	4.18	4.51	4.84	5.20	5.56	5.94	6.33	6.73	7.14	7.57	8.01	29	
30	2.82	3.09	3.38	3.68	4.00	4.32	4.66	5.01	5.38	5.75	6.14	6.55	6.96	7.37	7.83	8.28	30	

TABLE FOR MEASURING CORD WOOD WITH CALIPERS.

Length Feet.	Diameter in Inches.						
	4	5	6	7	8	9	10
Contents in Cubic Feet of Stacked Wood (Stacked, not Solid, Cubic Feet.)							
6	0.7	1.0	1.5	2.0	2.7	3.3	4.2
7	.8	1.2	1.8	2.3	3.1	3.9	4.8
8	.9	1.3	2.0	2.7	3.5	4.5	5.5
9	1.0	1.6	2.3	3.0	4.0	5.0	6.3
10	1.1	1.8	2.5	3.3	4.4	5.6	6.9
11	1.2	1.9	2.8	3.7	4.8	6.2	7.6
12	1.3	2.1	3.0	4.1	5.3	6.8	8.3
13	1.4	2.3	3.3	4.4	5.8	7.3	9.0
14	1.6	2.4	3.5	4.8	6.2	7.8	9.7
15	1.7	2.6	3.8	5.1	6.7	8.5	10.4
16	1.8	2.8	4.0	5.4	7.1	9.0	11.1
17	1.9	2.9	4.2	5.8	7.5	9.5	11.8
18	2.0	3.1	4.5	6.1	8.0	10.1	12.5
19	2.1	3.3	4.8	6.4	8.4	10.7	13.2
20	2.3	3.5	5.0	6.8	8.8	11.3	13.8

	Diameter in Inches.						
	11	12	13	14	15	16	17
Contents in Cubic Feet of Stacked Wood (Stacked, not Solid, Cubic Feet.)							
6	5.0	6.0	7.0	8.2	9.3	10.7	12.0
7	5.8	7.0	8.2	9.5	10.9	12.4	14.0
8	6.7	8.0	9.3	10.8	12.5	14.2	16.0
9	7.5	9.0	10.5	12.3	14.0	16.0	18.0
10	8.3	10.0	11.7	13.6	15.6	17.8	20.0
11	9.3	11.0	12.8	14.9	17.2	19.5	22.0
12	10.1	12.0	14.1	16.3	18.8	21.3	24.1
13	10.9	13.0	15.3	17.7	20.3	23.1	26.1
14	11.8	14.0	16.4	19.0	21.8	24.8	28.1
15	12.6	15.0	17.6	20.4	23.4	26.7	30.1
16	13.4	16.0	18.8	21.8	25.0	28.4	32.1
17	14.3	17.0	19.9	23.1	26.5	30.2	34.1
18	15.1	18.0	21.1	24.5	28.1	32.0	36.1
19	15.9	19.0	22.3	25.8	29.7	33.8	38.1
20	16.8	20.0	23.4	27.2	31.4	35.5	40.1

TABLE FOR MEASURING CORD WOOD WITH CALIPERS—(Continued).

Length, Feet.	Diameter in Inches.						
	18	19	20	21	22	23	24
Contents in Cubic Feet of Stacked Wood (Stacked, not Solid, Cubic Feet).							
6	13.5	15.0	16.7	18.3	20.2	22.0	24.0
7	15.9	17.6	19.4	21.4	23.5	25.7	28.0
8	18.0	20.0	22.2	24.5	26.8	29.3	32.0
9	20.3	22.5	25.0	27.5	30.3	33.0	36.0
10	22.5	25.0	27.8	30.6	33.6	36.7	40.0
11	24.8	27.4	30.5	33.7	36.9	40.3	44.0
12	27.0	30.1	33.3	36.8	40.3	44.1	48.0
13	29.3	32.6	36.1	39.8	43.7	47.8	52.0
14	31.5	35.1	38.8	42.8	47.0	51.4	56.0
15	33.8	37.6	41.7	45.9	50.4	55.1	60.0
16	36.0	40.1	44.4	49.0	53.8	58.8	64.0
17	38.3	42.6	47.2	52.0	57.1	62.4	68.0
18	40.5	45.1	50.0	55.1	60.5	66.1	72.0
19	42.8	47.3	52.8	58.1	63.8	69.8	76.0
20	45.0	50.1	55.5	61.3	67.2	73.4	80.0

VOLUME TABLES FOR STANDING TREES AND TABLES OF FORM FACTORS.

The majority of volume tables made in this country have been based on diameter without regard to height. They have, therefore, a purely local value and will be replaced by volume tables which take into consideration the height, merchantable length, number of logs, or tree classes. The author has not included in the following pages any tables based on diameter alone.

The tables of form factors of European pine, spruce, beech, and oak are given mainly as illustrations. The forester wishing to make a special study of European form factors should consult the special books on these subjects enumerated in the bibliography.

VOLUME TABLE FOR WHITE PINE.*—CUBIC CONTENTS OF STEMS, INCLUDING BARK.
 [Based on the measurement of 700 trees.]

Diam. Breast-high, Inches.	Height in Feet.														Form Factor.	
	40	45	50	55	60	65	70	75	80	85	90	95	100	105		110
7	5.4	6.0	6.7	7.4	8.0	8.0	8.0	8.0	8.0	8.0	8.0	8.0	8.0	8.0	8.0	0.502
8	6.9	7.8	8.7	9.5	10.4	11.0	11.6	12.2	12.8	13.4	14.0	14.6	15.2	15.8	16.4	.497
9	8.7	9.8	10.9	12.0	13.0	14.1	15.1	16.2	17.2	18.2	19.2	20.2	21.2	22.2	23.2	.492
10	10.7	12.0	13.3	14.6	15.9	17.3	18.6	19.9	21.2	22.4	23.6	24.8	26.0	27.2	28.4	.488
11	12.8	14.4	16.0	17.6	19.2	20.8	22.4	24.0	25.6	27.2	28.8	30.4	32.0	33.6	35.2	.484
12	15.0	17.0	19.0	21.0	23.0	25.0	27.0	29.0	31.0	33.0	35.0	37.0	39.0	41.0	43.0	.480
13	17.4	19.8	22.2	24.6	27.0	29.4	31.8	34.2	36.6	39.0	41.4	43.8	46.2	48.6	51.0	.477
14	20.0	22.8	25.6	28.4	31.2	34.0	36.8	39.6	42.4	45.2	48.0	50.8	53.6	56.4	59.2	.474
15	22.8	25.8	28.8	31.8	34.8	37.8	40.8	43.8	46.8	49.8	52.8	55.8	58.8	61.8	64.8	.470
16	25.8	29.0	32.2	35.4	38.6	41.8	45.0	48.2	51.4	54.6	57.8	61.0	64.2	67.4	70.6	.465
17	29.0	32.4	35.8	39.2	42.6	46.0	49.4	52.8	56.2	59.6	63.0	66.4	69.8	73.2	76.6	.460
18	32.4	36.0	39.6	43.2	46.8	50.4	54.0	57.6	61.2	64.8	68.4	72.0	75.6	79.2	82.8	.452
19	36.0	40.0	44.0	48.0	52.0	56.0	60.0	64.0	68.0	72.0	76.0	80.0	84.0	88.0	92.0	.445
20	40.0	44.4	48.8	53.2	57.6	62.0	66.4	70.8	75.2	79.6	84.0	88.4	92.8	97.2	101.6	.440
21	44.4	49.2	54.0	58.8	63.6	68.4	73.2	78.0	82.8	87.6	92.4	97.2	102.0	106.8	111.6	.430
22	49.2	54.4	59.6	64.8	70.0	75.2	80.4	85.6	90.8	96.0	101.2	106.4	111.6	116.8	122.0	.426
23	54.4	60.0	65.6	71.2	76.8	82.4	88.0	93.6	99.2	104.8	110.4	116.0	121.6	127.2	132.8	.424
24	60.0	66.0	72.0	78.0	84.0	90.0	96.0	102.0	108.0	114.0	120.0	126.0	132.0	138.0	144.0	.423
25	66.0	72.4	78.8	85.2	91.6	98.0	104.4	110.8	117.2	123.6	130.0	136.4	142.8	149.2	155.6	.420
26	72.4	79.2	86.0	92.8	99.6	106.4	113.2	120.0	126.8	133.6	140.4	147.2	154.0	160.8	167.6	.419
27	79.2	86.4	93.6	100.8	108.0	115.2	122.4	129.6	136.8	144.0	151.2	158.4	165.6	172.8	180.0	.418
28	86.4	94.0	101.6	109.2	116.8	124.4	132.0	139.6	147.2	154.8	162.4	170.0	177.6	185.2	192.8	.417
29	94.0	102.0	110.0	118.0	126.0	134.0	142.0	150.0	158.0	166.0	174.0	182.0	190.0	198.0	206.0	.415
30	102.0	110.4	118.8	127.2	135.6	144.0	152.4	160.8	169.2	177.6	186.0	194.4	202.8	211.2	219.6	.413
31	110.4	119.2	128.0	136.8	145.6	154.4	163.2	172.0	180.8	189.6	198.4	207.2	216.0	224.8	233.6	.412
32	119.2	128.4	137.6	146.8	156.0	165.2	174.4	183.6	192.8	202.0	211.2	220.4	229.6	238.8	248.0	.410
33	128.4	138.0	147.6	157.2	166.8	176.4	186.0	195.6	205.2	214.8	224.4	234.0	243.6	253.2	262.8	.409
34	138.0	148.0	158.0	168.0	178.0	188.0	198.0	208.0	218.0	228.0	238.0	248.0	258.0	268.0	278.0	.408
35	148.0	158.4	168.8	179.2	189.6	199.6	209.6	219.6	229.6	239.6	249.6	259.6	269.6	279.6	289.6	.407
36	158.4	169.2	180.0	190.8	201.6	212.4	223.2	234.0	244.8	255.6	266.4	277.2	288.0	298.8	309.6	.406
37	169.2	180.4	191.6	202.8	214.0	225.2	236.4	247.6	258.8	270.0	281.2	292.4	303.6	314.8	326.0	.405

* From the White Pine, Bull. 22, Division of Forestry.

VOLUME TABLE FOR WHITE PINE.—CUBIC CONTENTS OF STEMS, INCLUDING BARK—(Continued).

Diam. Breast- high Inches.	Height in Feet.														Diam. Breast- high Inches.	Form Factor.		
	115	120	125	130	135	140	145	150	155	160	165	170	175					
	Cubic Feet.																	
13	50.6	52.8															13	0.477
14	57.8	60.3															14	.474
15	66.5	69.4	72.3														15	.470
16	74.1	77.3	80.5														16	.465
17	83.0	86.6	90.2														17	.460
18	91.9	95.9	99.9														18	.452
19	100.9	105.3	109.7	114.1													19	.445
20	110.4	115.2	120.0	124.8	140.0												20	.440
21	119.2	124.4	129.6	134.8	140.0	151.6											21	.430
22	129.2	134.8	140.4	146.0	151.6	171.1	177.2										22	.426
23	140.6	146.7	152.8	158.9	165.0	171.1	186.2										23	.424
24	146.6	153.2	159.8	166.4	173.0	179.6	186.2										24	.423
25	164.3	171.4	178.5	185.6	192.7	199.8	206.9										25	.420
26	177.3	185.0	192.7	200.4	208.1	215.8	223.5										26	.419
27	191.1	199.4	207.7	216.0	224.3	232.6	240.9	249.2									27	.418
28	205.0	213.9	222.8	231.7	240.6	249.5	258.4	267.3	276.2								28	.417
29	218.8	228.3	237.8	247.3	256.8	266.3	275.8	285.3	294.8								29	.415
30	233.0	240.1	250.2	260.3	270.4	280.5	290.6	300.7	310.8								30	.413
31	248.3	259.1	269.9	280.7	291.5	302.3	313.1	323.9	334.7								31	.412
32	263.2	274.6	286.0	297.4	308.8	320.2	331.6	343.0	354.4								32	.410
33	279.2	291.3	303.4	315.5	327.6	339.7	351.8	363.9	376.0	388.1							33	.409
34	295.9	308.8	321.7	334.6	347.5	360.4	373.3	386.2	399.1	412.0							34	.408
35	312.7	326.3	339.9	353.5	367.1	380.7	394.3	407.9	421.5	435.1	448.7	462.3	475.9				35	.407
36	329.9	344.2	358.5	372.8	387.1	401.4	415.7	430.0	444.3	458.6	472.9	487.2	501.5				36	.406
37	347.7	362.8	377.9	393.0	408.1	423.2	438.3	453.4	468.5	483.6	498.7	513.8	528.9				37	.405
38	365.9	381.8	397.7	413.6	429.5	445.4	461.3	477.2	493.1	509.0	524.9	540.8	556.7				38	.404
39			418.1	434.8	451.5	468.2	484.9	501.6	518.3	535.0	551.7	568.4	585.1				39	.403
40				437.4	454.9	472.4	489.9	507.4	524.9	542.4	559.9	577.4	594.9	612.4			40	.401
41									513.4	531.7	550.0	568.3	586.6	604.9	623.2	641.5	41	.400
42										537.4	556.6	575.8	595.0	614.2	633.4	652.6	42	.399
43											561.9	582.0	602.1	622.2	642.3	662.4	43	.398
44												586.9	607.8	628.7	649.6	670.5	44	.397
45													612.3	634.2	656.1	678.0	45	.396
46														638.2	661.0	683.8	46	.395
															720.4	752.2		
																775.0		

VOLUME TABLE FOR WHITE PINE OVER 100 YEARS OLD.*

[Based on 100 trees.]

Diam., Breast- high, Inches.	Height of Tree in Feet.																	Diam., Breast- high, Inches.		
	65	70	75	80	85	90	95	100	105	110	115	120	125	130	135	140	145		150	155
10	26	28	30	32	34	10
12	56	61	65	69	74	78	83	12
14	98	105	113	120	128	135	143	150	14
16	...	153	164	175	185	196	207	218	229	240	16
18	227	242	256	272	287	302	317	332	18
20	323	343	363	383	403	423	443	463	20
22	418	444	470	496	522	549	575	601	627	22
24	561	595	627	660	694	726	760	793	826	24
26	720	760	800	840	880	920	960	1000	1040	1080	26
28	911	959	1007	1055	1103	1151	1199	1247	1295	1343	28
30	1138	1195	1252	1308	1365	1422	1479	1536	1593	30
32	1440	1505	1571	1636	1702	1767	1832	2018	32
34	1717	1792	1866	1941	2016	2090	2165	34
36	2033	2118	2203	2288	2372	2457	2541	...	36
38	2394	2490	2585	2680	2776	2871	...	38
40	2802	2909	3018	3125	3233	3340	40

Board Feet by the Doyle Rule.

* From The White Pine, by Gifford Pinchot and H. S. Graves.

VOLUME TABLE FOR SPRUCE, IN BOARD FEET.*

Diam. Breast-high, Inches.	Height of Tree in Feet.																Diam. Breast-high, Inches.		
	25	30	35	40	45	50	55	60	65	70	75	80	85	90	95	100			
9	18	21	24	27	30	34	38	42	48	53	59	65	70	75	80	85	90	95	100
10	25	29	34	38	44	50	55	61	67	73	79	85	91	97	103	109	115	121	127
11	34	39	44	49	55	61	68	74	81	87	93	99	105	111	117	123	129	135	141
12	48	56	63	71	79	87	94	102	110	118	126	134	142	150	158	166	174	182	190
13	63	73	82	92	102	112	122	132	142	152	162	172	182	192	202	212	222	232	242
14	71	82	94	106	118	130	142	154	166	178	190	202	214	226	238	250	262	274	286
15	79	92	106	120	134	148	162	176	190	204	218	232	246	260	274	288	302	316	330
16	102	120	138	156	174	192	210	228	246	264	282	300	318	336	354	372	390	408	426
17	135	152	173	193	214	236	258	280	302	324	346	368	390	412	434	456	478	500	522
18	167	190	214	238	262	286	310	334	358	382	406	430	454	478	502	526	550	574	598
19	207	237	266	296	326	356	386	416	446	476	506	536	566	596	626	656	686	716	746
20	265	294	324	354	384	414	444	474	504	534	564	594	624	654	684	714	744	774	804
21	322	357	392	427	462	497	532	567	602	637	672	707	742	777	812	847	882	917	952
22	390	430	470	510	550	590	630	670	710	750	790	830	870	910	950	990	1030	1070	1110
23	435	475	515	555	595	635	675	715	755	795	835	875	915	955	995	1035	1075	1115	1155
24	509	559	609	659	709	759	809	859	909	959	1009	1059	1109	1159	1209	1259	1309	1359	1409

Contents in Board Feet.†

* From The Adirondack Spruce, by Gifford Pinchot. † By the Scribner Rule.

TABLES FOR STANDING TREES AND FORM FACTORS. 407

VOLUME TABLE FOR SPRUCE, IN CUBIC FEET.*

Diameter, Breast-high, Inches.	Height of Tree in Feet.									
	25	30	35	40	45	50	55	60	65	
	Merchantable Cubic Feet of Pulp-wood.									
5	1.1	1.2	1.3	1.4	1.5	1.6	1.7			
6	1.6	1.8	2.1	2.4	2.8	3.2	3.6	4.0		
7	2.1	2.5	3.0	3.6	4.2	4.8	5.4	6.0	6.6	
8	3.1	3.9	4.8	5.6	6.5	7.3	8.0	8.8	
9	3.8	4.9	5.9	6.9	8.0	9.0	9.9	11.0	
10	6.0	7.2	8.4	9.6	10.9	12.2	13.5	
11	7.1	8.6	10.1	11.6	13.1	14.6	16.1	
12	10.0	11.7	13.5	15.2	17.0	18.8	
13	13.4	15.4	17.3	19.4	21.5	
14	15.1	17.3	19.5	21.8	24.2	

* From The Adirondack Spruce, by Gifford Pinchot.

VOLUME TABLE FOR CHESTNUT.

DOMINANT TREES ABOUT 50 YEARS OLD.

[Based on 99 trees measured in Milford, Pa.]

Diameter, Breast-high, Inches.	Height in Feet.				
	40	45	50	55	60
	Merchantable Cubic Feet.				
6	3.4	3.8	4.1		
7	4.7	5.2	5.6	6.0	
8	6.1	6.7	7.3	7.9	
9	7.8	8.5	9.3	10.0	
10	9.6	10.5	11.4	12.3	
11	11.6	12.7	13.9	14.9	
12	15.2	16.5	17.7	
13	17.8	19.4	20.9	
14	20.6	22.3	24.2	
15	25.8	27.7	
				29.7	

FOREST MENSURATION.

VOLUME TABLES FOR PITCH PINE.

DOMINANT TREES 60 TO 80 YEARS OLD.

[Based on 75 trees measured in Milford, Pa.]

Diameter, Breast-high Inches.	Fuel-wood.		
	45'-54' Trees.	55'-64' Trees.	Trees of all Heights.
	Cubic Feet.		
9	9.6	9.6
10	11.9	15.7	12.3
11	14.6	17.8	15.5
12	18.0	20.5	19.2
13	22.1	23.9	23.4
14	27.0	28.1	28.3
15	33.4	34.0
16	39.8	40.1
17	47.8	47.3

Diameter, Breast-high Inches.	Lumber and Fuel-wood.					
	One-log Trees.		Two-log Trees.		Three-log Trees.	
	Board Feet.	Cords.	Board Feet.	Cords.	Board Feet.	Cords.
9	19	0.045	28	0.023	-	-
10	22	.059	33	.028	43	0.017
11	27	.075	41	.033	52	.021
12	33	.095	51	.039	63	.026
13	41	.120	64	.047	76	.031
14	52	79	.057	93	.038
15	97	.069	114	.046
16	117	141	.056
17	177	.070

VOLUME TABLE FOR RED OAK.

[Based on 130 trees measured at New Haven, Conn.]

Diameter, Breast- high, Inches.	Height of Tree in Feet.							
	20	25	30	35	40	45	50	55
	Merchantable Cord-wood in Cubic Feet.							
5	1.23	1.61	1.91	2.24	2.55	2.91	3.12	3.40
6	1.78	2.31	2.83	3.31	3.77	4.22	4.61	5.04
7	3.79	4.40	5.08	5.68	6.25	6.79
8	4.88	5.75	6.56	7.31	7.99	8.75
9	8.31	9.27	10.13	10.97
10	12.62	13.64
11	15.70	16.87

Diameter, Breast- high, Inches.	Height of Tree in Feet.						
	60	65	70	75	80	85	90
	Merchantable Cord-wood in Cubic Feet.						
5	3.66						
6	5.45	5.81	6.16				
7	7.32	7.81	8.31	8.78	9.27		
8	9.43	10.07	10.70	11.31	11.93		
9	11.76	12.62	13.31	14.04	14.75		
10	14.63	15.62	16.52	17.42	18.30	19.20	
11	18.04	19.16	20.18	21.17	22.15	23.12	24.06
12	22.33	23.62	24.90	26.04	27.15	28.16	29.14
13	27.33	28.85	30.34	31.62	32.98	34.21	35.40

FORM FACTORS OF SCOTCH PINE IN NORTH GERMANY *
 [Based on the volume of wood above 7 centimeters.]

Height, Meters.	Diameter Classes in Centimeters.							
	21-25	26-30	31-35	36-40	41-45	46-50	51-55	56-60
	Form Factors.							
12	.500							
13	.495							
14	.491	.492						
15	.487	.488						
16	.483	.484	.487					
17	.479	.480	.483					
18	.475	.476	.479	.477				
19	.471	.473	.475	.474				
20	.468	.470	.472	.471	.470	.465		
21	.465	.467	.469	.467	.466	.463		
22	.462	.464	.467	.465	.463	.461	.457	
23	.459	.461	.465	.463	.462	.460	.457	
24	.456	.459	.463	.462	.461	.459	.456	.455
25	.453	.457	.461	.461	.460	.459	.456	.455
26	.450	.455	.460	.460	.459	.458	.456	.455
27	.449	.454	.459	.459	.458	.458	.457	.456
28	.448	.454	.458	.459	.458	.458	.457	.457
29453	.457	.458	.458	.458	.458	.457
30453	.456	.457	.458	.458	.458	.458
31455	.457	.457	.457	.458	.459
32455	.457	.457	.458	.459	.460
33457	.458	.459	.460	.460
34457	.459	.460	.461	.461
35459	.461	.462	.461
36460	.461	.462	.461

* From Formzahlen und Massentafeln für die Kiefer, by Dr. Schwappach, 1890.

STEM FORM FACTORS OF SPRUCE OVER 90 YEARS OLD.*

Diameter, Breast- high, Centime- ters.	Form Factor.	Diameter, Breast- high, Centime- ters.	Form Factor.	Diameter, Breast- high, Centime- ters.	Form Factor.	Diameter, Breast- high, Centime- ters.	Form Factor.
10	.559	34	.466	58	.414	80	.370
12	.544	36	.462	60	.410	82	.367
14	.532	38	.457	62	.406	84	.365
16	.522	40	.453	64	.401	86	.363
18	.513	42	.449	66	.397	88	.361
20	.505	44	.444	68	.393	90	.3595
22	.498	46	.440	70	.388	92	.358
24	.492	48	.436	72	.384	94	.3565
26	.486	50	.431	74	.380	96	.355
28	.480	52	.427	76	.376	98	.354
30	.475	54	.423	78	.373	100	.3535
32	.470	56	.419				

* From Behm's Massentafeln.

FORM FACTORS OF EUROPEAN OAK.*

[Based on the volume of wood above 7 centimeters.]

Height, Meters.	Diameter at Breast-height in Centimeters.									
	10	15	20	25	30	35	40	45	50	55
	Form Factors.									
6	.285									
7	.298	.506								
8	.316	.500	.553							
9	.338	.495	.538	.548						
10	.361	.491	.429	.542	.555					
11	.378	.488	.524	.538	.550	.557				
12	.395	.486	.520	.534	.544	.551	.565			
13	.409	.484	.514	.530	.540	.545	.559	.564		
14	.424	.482	.512	.526	.435	.541	.555	.560	.565	.570
15	.437	.481	.507	.523	.431	.536	.550	.556	.560	.566
16	.448	.479	.506	.521	.528	.533	.546	.553	.556	.563
17	.454	.478	.504	.519	.525	.530	.543	.550	.553	.560
18	.460	.477	.502	.517	.523	.528	.541	.548	.550	.557
19476	.501	.515	.521	.526	.537	.545	.547	.554
20475	.500	.513	.519	.524	.534	.542	.545	.551
21474	.499	.511	.517	.523	.531	.538	.542	.548
22474	.498	.510	.516	.522	.529	.535	.539	.545
23497	.509	.515	.521	.527	.532	.536	.542
24496	.508	.514	.520	.526	.530	.534	.539
25495	.505	.513	.519	.524	.528	.532	.537
26496	.503	.511	.518	.523	.527	.531	.536
27501	.510	.517	.522	.526	.530	.535
28497	.508	.516	.521	.525	.529	.534
29494	.506	.514	.520	.523	.528	.532
30491	.504	.512	.519	.522	.526	.531
31488	.502	.510	.518	.521	.526	.530
32500	.509	.516	.520	.524	.529
33498	.507	.514	.519	.523	.527
34497	.504	.511	.516	.521	.525
35495	.502	.509	.513	.519	.523
36493	.500	.505	.511	.516	.521
37497	.503	.508	.514	.519
38495	.500	.505	.511	.516
39493	.498	.503	.509	.514
40490	.496	.501	.507	.512

* From Formzahlen und Massentafeln für die Eiche, by Dr. Schwappach, 1905.

FORM FACTORS OF EUROPEAN OAK—(Continued).

Height, Meters.	Diameter at Breast-height in Centimeters.								
	60	65	70	75	80	85	90	95	100
	Form Factors.								
14	.575								
15	.570	.575							
16	.566	.571	.570						
17	.563	.567	.571	.576					
18	.560	.564	.568	.572	.580				
19	.557	.561	.565	.569	.576	.585			
20	.554	.558	.562	.566	.571	.576			
21	.551	.555	.559	.563	.567	.572	.577		
22	.548	.551	.556	.560	.564	.569	.574	.586	
23	.544	.549	.554	.558	.562	.567	.572	.584	.595
24	.542	.547	.552	.556	.560	.565	.570	.581	.591
25	.541	.545	.550	.555	.558	.563	.569	.577	.587
26	.540	.544	.549	.554	.557	.562	.568	.574	.582
27	.539	.543	.548	.553	.556	.560	.566	.571	.578
28	.538	.542	.547	.551	.554	.559	.564	.568	.573
29	.537	.541	.545	.550	.552	.557	.561	.566	.571
30	.535	.539	.543	.548	.551	.555	.559	.564	.568
31	.534	.537	.542	.546	.549	.554	.556	.562	.566
32	.533	.536	.540	.544	.547	.552	.555	.560	.564
33	.531	.534	.537	.542	.545	.550	.553	.558	.562
34	.530	.533	.535	.541	.543	.548	.551	.555	.559
35	.528	.532	.534	.539	.542	.546	.549	.553	.556
36	.526	.530	.533	.538	.541	.544	.547	.550	.553
37	.524	.528	.531	.536	.538	.542	.544	.547	.549
38	.522	.526	.529	.533	.536	.539	.541	.544	.545
39	.519	.524	.527	.530	.531	.532	.534	.536	.538
40	.517	.522	.526	.529	.530	.531	.533	.535	.537

FORM FACTORS OF EUROPEAN BEECH—(Continued).

Height, Meters.	Diameter at Breast-height in Centimeters.																Height, Meters.	
	40	42	44	46	48	50	52	54	56	58	60	62	64	66	68	70		72
20	501
21	502	505
22	504	506	507
23	505	507	508	509	511	513	515	516	519	521	523	525	527	529	531	533	535	536
24	506	508	509	511	512	514	516	518	520	522	524	526	528	530	532	534	536	538
25	507	508	510	512	513	515	517	519	521	523	525	527	529	531	533	535	537	539
26	508	509	511	513	515	516	518	521	522	524	526	528	530	532	534	536	538	540
27	509	510	512	514	516	518	519	522	524	526	528	530	532	534	536	538	540	541
28	510	511	513	515	517	519	521	523	525	527	529	531	533	535	537	539	541	542
29	510	512	514	516	518	520	522	524	526	528	530	532	534	536	538	540	541	542
30	511	514	516	518	520	522	525	527	529	531	533	535	537	539	541	542	543	544
31	513	515	517	519	521	523	526	528	530	532	534	536	538	540	542	544	546	547
32	514	515	517	519	522	523	526	527	530	532	534	536	538	540	542	544	546	547
33	515	516	519	520	523	525	527	529	531	533	535	536	538	539	540	542	543	544
34	516	517	520	522	524	526	528	530	532	534	536	538	539	540	542	543	544	544
35	517	519	521	523	525	527	529	531	534	535	538	539	540	541	543	545	546	546
36	518	520	522	524	526	528	530	532	535	537	538	541	542	543	544	546	547	547
37	518	521	523	525	527	529	531	534	536	538	539	541	543	545	546	547	549	549
38	519	522	524	526	528	530	532	535	537	538	540	542	544	546	547	548	549	549
39	520	523	525	527	529	531	533	535	537	539	541	544	546	548	549	549	550	550

FORM FACTORS OF EUROPEAN TREES.

[Based on heights.]

Height, Meters.	Spruce (after Baur).		Scotch Pine (after Kunze).		Silver Fir (after Schuberg).		Beech (after Kunze).	
	Tree Form Factor.	Merch. Form Factor.*	Tree Form Factor.	Merch. Form Factor.*	Tree Form Factor.	Merch. Form Factor.*	Tree Form Factor.	Merch. Form Factor.*
5	.9793	.07	.9784	
6	.89	.10	.84	.14	.8980	
7	.85	.18	.78	.21	.83	.31	.75	.01
8	.81	.27	.73	.27	.79	.35	.72	.07
9	.77	.33	.68	.33	.76	.42	.69	.14
10	.75	.38	.65	.36	.73	.47	.66	.20
11	.73	.42	.63	.40	.71	.50	.64	.28
12	.70	.45	.61	.44	.69	.51	.62	.37
13	.69	.48	.59	.47	.68	.52	.61	.41
14	.67	.49	.58	.48	.67	.53	.60	.43
15	.66	.50	.57	.48	.65	.53	.59	.44
16	.65	.51	.56	.48	.65	.53	.58	.46
17	.64	.51	.55	.47	.64	.53	.58	.47
18	.63	.51	.54	.47	.63	.53	.58	.47
19	.62	.51	.53	.47	.63	.53	.57	.48
20	.62	.51	.53	.46	.62	.53	.57	.48
21	.61	.51	.52	.46	.62	.53	.57	.49
22	.60	.51	.52	.46	.61	.53	.57	.49
23	.59	.51	.51	.45	.60	.52	.57	.49
24	.58	.50	.51	.45	.60	.52	.57	.49
25	.58	.50	.50	.45	.59	.52	.57	.50
26	.57	.49	.50	.45	.59	.51	.56	.50
27	.56	.49	.50	.45	.58	.51	.56	.50
28	.55	.49	.50	.45	.58	.51	.56	.50
29	.55	.48	.49	.45	.57	.50	.56	.50
30	.54	.48	.49	.45	.56	.50	.56	.50
31	.53	.47	.49	.46	.56	.49	.56	.50
32	.52	.47	.49	.46	.55	.49	.56	.50
33	.52	.46	.49	.46	.54	.48	.56	.50
34	.51	.46	.49	.46	.54	.47		
35	.51	.4653	.47		
36	.50	.4552	.47		
37	.49	.4551	.46		
38	.49	.4450	.45		
39	.48	.4449	.45		
40	.48	.4348	.44		

* Based on the volume of wood over 7 centimeters in diameter.

TABLES OF GROWTH AND YIELD.

The U. S. Forest Service has made extensive local studies of growth of a large number of different species, but the material has for the most part not yet been published and is, therefore, not available for this work. The author has, in consequence, not attempted to give an exhaustive list of tables of growth. A few tables have, however, been given which are likely to prove of general use.

The investigations in the study of yield have not yet progressed far enough to justify the publication of a series of yield tables. A number of local yield tables for many-aged forests have been published, but the majority cannot be used, except in the localities where they were made. The yield tables for spruce shown on pages 422 and 424 are included for the purpose of illustration. In the absence of general yield tables for spruce they may serve a useful purpose. They have been constructed to show the future yield, after cutting to diameter limits of 10, 12, and 14 inches, of stands having an original yield, for trees 10 inches and over in diameter, of 1000, 2000, 3000 board feet, etc. They were prepared for use on a tract of 40,000 acres at Nehasane, Herkimer Co., N. Y.

The author has translated portions of the German yield tables of Scotch pine, spruce, and beech. These tables will be useful as a standard of comparison when similar tables are constructed in this country. The tables on page 435 were used in translating from the metric to the English units.

NORMAL YIELD TABLE FOR SPRUCE.*

QUALITY I.

Age, Years.	Number of Trees per Acre.	Basal Area, Sq. Ft.	Average Height, Feet.	Diameter of Average Tree, Inches.	Yield per Acre, Cu. Ft.	Yield per Acre of Thinnings, Cu. Ft.	Forest Form Factor.
10	37.2	7.5		
20	2940	97.3	20.0	2.6	700	..	.360
30	1780	168.5	35.1	4.2	2915	57	.490
40	1120	205.6	51.5	5.8	5545	214	.519
50	716	226.8	65.3	7.6	7746	386	.519
60	500	242.0	76.4	9.4	9546	457	.511
70	380	252.3	85.3	11.0	11018	457	.505
80	308	260.9	92.8	12.4	13247	414	.500
90	256	269.1	99.0	13.9	13205	357	.495
100	220	276.5	104.3	15.2	14248	314	.490
110	200	283.0	108.6	16.1	15120	271	.488
120	189	288.6	111.9	16.7	15892	243	.487

* From Wachstum und Ertrag normaler Fichtenbestände, by Adam Schwappach, Berlin, 1890.

NORMAL YIELD TABLE FOR SPRUCE.

QUALITY III.

Age, Years.	Number of Trees per Acre.	Basal Area, Sq. Ft.	Average Height, Feet.	Diameter of Average Tree, Inches.	Yield per Acre, Cu. Ft.	Yield per Acre of Thinnings, Cu. Ft.	Forest Form Factor.
10	3.6				
20	61.3	10.2	
30	3300	102.3	19.4	2.4	672331
40	1924	140.8	30.2	3.7	2115	29	.495
50	1216	162.4	42.0	4.9	3673	129	.534
60	840	178.9	52.2	6.2	5959	229	.539
70	628	189.2	61.0	7.4	6274	243	.539
80	500	200.0	68.9	8.5	7317	229	.534
90	424	209.5	73.6	9.5	8217	200	.528
100	380	217.7	78.4	10.2	8960	186	.522
110	346	224.2	82.0	10.9	9632	171	.520
120	320	229.8	84.6	11.8	10232	143	.520

NORMAL YIELD TABLE FOR SPRUCE.

QUALITY V.

Age, Years.	Number of Trees per Acre.	Basal Area, Sq. Ft.	Average Height, Feet.	Diameter of Average Tree, Inches.	Yield per Acre, Cu. Ft.	Yield per Acre of Thinnings, Cu. Ft.	Forest Form Factor.
10	1.3				
20	38.0	4.2				
30	60.5	8.9	
40	3920	86.4	15.1	2.0	343	..	.261
50	2128	107.1	22.0	3.0	957	..	.403
60	1356	121.8	29.5	4.1	1872	43	.516
70	988	133.1	37.1	5.0	2758	86	.555
80	800	142.6	43.0	5.7	3530	86	.567
90	696	150.8	47.5	6.3	4144	71	.573
100	640	157.2	50.8	6.7	4630	71	.574

NORMAL YIELD TABLE FOR BEECH.*

QUALITY I.

Age, Years.	Number of Trees per Acre.	Basal Area, Sq. Ft.	Average Height, Feet.	Diameter of Average Tree, Inches.	Yield per Acre, Cu. Ft.	Yield per Acre of Thinnings, Cu. Ft.	Forest Form Factor.
20	2524	39.1	18.0	1.7			
30	1526	73.4	31.5	3.0	68629
40	934	104.5	44.6	4.5	1943	129	.41
50	598	129.6	56.1	6.3	3330	229	.45
60	423	146.9	66.9	7.9	4602	286	.46
70	327	159.0	76.4	9.4	5802	314	.47
80	269	168.5	84.6	10.7	6903	314	.48
90	228	175.8	91.5	11.9	7905	314	.49
100	196	182.3	97.1	13.0	8860	286	.50
110	174	187.5	102	14.0	9732	271	.50
120	157	192.2	106	15.0	10518	257	.51

* From Wachstum und Ertrag normaler Rothbuchenbestände, by Adam Schwappach, Berlin, 1893.

NORMAL YIELD TABLE FOR BEECH.

QUALITY III.

Age, Years.	Number of Trees per Acre.	Basal Area, Sq. Ft.	Average Height, Feet.	Diameter of Average Tree, Inches.	Yield per Acre, Cu. Ft.	Yield per Acre of Thinnings, Cu. Ft.	Forest Form Factor.
30	2044	52.7	23.0	2.1	86		
40	1372	79.9	33.5	3.3	943	..	.35
50	960	103.7	43.0	4.4	2001	86	.45
60	724	120.1	51.8	5.5	2915	143	.46
70	572	130.0	59.7	6.4	3716	171	.47
80	460	136.1	66.9	7.3	4430	186	.48
90	380	140.0	73.2	8.2	5045	200	.49
100	320	143.0	78.7	9.0	5573	200	.49
110	275	145.6	83.3	9.8	6045	200	.49
120	239	148.2	86.9	10.6	6459	200	.50

NORMAL YIELD TABLE FOR BEECH.

QUALITY V.

Age, Years.	Number of Trees per Acre.	Basal Area, Sq. Ft.	Average Height, Feet.	Diameter of Average Tree, Inches.	Yield per Acre, Cu. Ft.	Yield per Acre of Thinnings, Cu. Ft.	Forest Form Factor.
40	1976	56.2	20.3	2.3	400	..	.35
50	1496	79.1	27.9	3.1	929	..	.42
60	1192	97.2	34.1	3.8	1529	..	.46
70	984	107.6	39.4	4.4	2044	..	.48
80	824	113.6	43.6	5.0	2415	43	.48
90	696	116.3	47.2	5.1	2672	71	.48
100	600	117.1	49.9	6.0	2858	71	.48
110	524	116.2	52.2	6.4	2987	86	.49
120	464	115.3	54.1	6.7	3073	86	.49

NORMAL YIELD TABLE FOR SCOTCH PINE.*

QUALITY I.

Age, Years.	Number of Trees per Acre.	Basal Area, Sq. Ft.	Average Height, Feet.	Diameter of Average Tree, Inches.	Yield per Acre, Cu. Ft.	Yield per Acre of Thinnings, Cu. Ft.	Forest Form Factor.
10	12.1				
20	1696	107.1	29.2	3.4	957304
30	1076	141.7	43.6	4.9	2244	171	.361
40	696	162.0	55.4	6.5	3573	214	.394
50	464	175.4	65.0	8.2	4602	271	.400
60	328	184.9	73.2	10.1	5459	286	.401
70	256	191.4	80.0	11.7	6202	271	.401
80	218	196.6	85.9	12.8	6831	229	.401
90	196	200.9	91.4	13.7	7346	196	.398
100	179	205.2	95.8	14.4	7760	157	.391
110	166	208.7	99.7	15.2	8117	143	.387
120	154	212.1	103	15.9	8446	143	.383

* From Wachstum und Ertrag normaler Kiefernbestände, by Adam Schwappach Berlin, 1889.

NORMAL YIELD TABLE FOR SCOTCH PINE.

QUALITY III.

Age, Years.	Number of Trees per Acre.	Basal Area, Sq. Ft.	Average Height, Feet.	Diameter of Average Tree, Inches.	Yield per Acre, Cu. Ft.	Yield per Acre of Thinnings, Cu. Ft.	Forest Form Factor.
10	6.6				
20	2600	60.9	17.4	2.2	329312
30	1784	101.1	30.2	3.2	1200	100	.388
40	1228	123.6	39.4	4.3	2086	143	.425
50	848	135.6	46.3	5.4	2829	200	.448
60	596	143.4	52.2	6.6	3458	229	.459
70	440	149.0	57.4	7.9	3973	214	.459
80	348	153.8	62.7	9.0	4387	186	.452
90	292	157.7	67.3	9.9	4745	143	.443
100	255	160.7	71.8	10.8	5045	129	.433
110	228	162.9	75.8	11.5	5288	100	.425
120	205	164.2	79.1	12.1	5488	86	.417

NORMAL YIELD TABLE FOR SCOTCH PINE.

QUALITY V.

Age Years.	Number of Trees per Acre.	Basal Area, Sq. Ft.	Average Height, Feet.	Diameter of Average Tree, Inches.	Yield per Acre, Cu. Ft.	Yield per Acre of Thinnings, Cu. Ft.	Forest Form Factor.
10	2.3				
20	6.6				
30	3200	57.9	14.8	1.9	186225
40	2256	81.2	21.0	2.6	586	57	.349
50	1588	93.3	25.9	3.3	1058	86	.455
60	1152	100.2	30.2	4.0	1429	86	.485
70	828	104.1	34.1	4.8	1743	86	.492
80	640	106.3	38.0	5.5	1986	71	.486
90	520	107.6	41.3	6.1	2158	57	.479
100	428	108.4	44.3	6.8	2287	57	.472

YIELD OF FULLY STOCKED STANDS OF SECOND-GROWTH WHITE PINE.*

Age of Stand Years.	Average Height, Feet.	Total Trees per Acre.	Merchantable Trees per Acre.	Yield per Acre, Cords.
10	5	2220		
15	9	1700		
20	14	1600		
25	22	1310	400	11
30	32	1090	510	21
35	45	885	620	30
40	54	690	540	38
45	62	510	460	45
50	68	400	380	53
55	72	300	300	65
60	76	260	260	80

* From The Natural Replacement of White Pine on Old Fields in New England, by S. N. Spring, Bull. No. 63, U. S. Forest Service, 1905.

LOCAL YIELD TABLE FOR ADIRONDACK SPRUCE.

TABLE A.

[Spruce per acre, 10 inches and over in diameter, breast-high.]

Yield of all Trees 10 Inches and over in Diameter. Breast-high in Thousand Feet, Board Measure.	Number of Acres Meas- ured.	Amount of First Cut, Board Feet.	Second Cut After Ten Years.		Second Cut After Twenty Years.		Second Cut After Thirty Years.		Interval Required Between Equal Cuts, Years.
			Number of Merchant- able Trees.	Board Feet.	Number of Merchant- able Trees.	Board Feet.	Number of Merchant- able Trees.	Board Feet.	
1	139	1416	5.3	255	12.1	738	20.8	1685	27
2	213	2382	5.4	323	12.8	868	21.1	1991	34
3	223	3480	6.5	325	14.3	914	23.5	2183	37
4	204	4228	7.5	375	15.7	1070	25.9	2420	39
5	106	5213	7.3	365	16.2	1087	26.8	2483	43
6	71	6005	8.8	440	18.5	1581	30.4	2913	43
7	37	7405	10.3	515	20.9	1436	33.7	2958	45
8	21	7868	9.4	517	19.2	1366	32.1	2899	47
9	4	9449	7.2	396	18.2	1239	30.9	2670	52
10	5	10499	8.6	473	17.0	1043	29.6	2938	51
11	1	11095	10.0	550	30.0	1980	47.0	4488	46
12	2	11772	13.0	715	26.5	1887	46.0	4542	48

LOCAL YIELD TABLE FOR ADIRONDACK SPRUCE—(Continued).

TABLE B.

[Spruce per acre, 12 inches and over in diameter, breast-high.]

Yield of all Trees 10 inches and over in Diameter. Breast-high, in Thousand Feet, Board Measure.	Amount of First Cut [Trees 12 ins. and over in Diameter]. Board Feet.		Second Cut After Ten Years.		Second Cut After Twenty Years.		Second Cut After Thirty Years.		Interval Required between Equal Cuts, Years.
	Number of Merchantable Trees [12 ins. and over].	Board Feet.	Number of Merchantable Trees [12 ins. and over].	Board Feet.	Number of Merchantable Trees [12 ins. and over].	Board Feet.	Number of Merchantable Trees [12 ins. and over].	Board Feet.	
1	7.8	632	13.1	1336	19.9	2504	16		
2	9.1	845	14.5	1560	21.9	2935	23		
3	11.4	1029	17.9	1850	25.7	3471	25		
4	12.4	1131	19.9	2115	28.1	3924	29		
5	14.3	1208	21.6	2325	30.5	4109	32		
6	15.5	1412	24.3	2685	34.0	4778	32		
7	19.4	1792	29.7	3320	40.3	5636	32		
8	17.0	1696	26.4	3019	36.2	5264	37		
9	19.5	1946	26.9	3148	37.9	5538	37		
10	16.8	1711	25.4	2964	33.8	5283	40		
11	20.0	2084	30.0	3564	50.0	7182	39		
12	29.0	2957	42.0	4759	55.5	8767	32		

LOCAL YIELD TABLE FOR ADIRONDACK SPRUCE—(Continued).

TABLE C.

[Spruce per acre, 14 inches and over in diameter, breast-high.]

Yield of all Trees 10 inches and over in Diameter, Breast-high, in Thousand Feet, Board Measure.	Amount of First Cut [Trees 14 Ins. and over in Diameter], Board Feet.	Second Cut After Ten Years.		Second Cut After Twenty Years.		Second Cut After Thirty Years.		Interval Required between Equal Cuts, Years.
		Number of Merchantable Trees [14 Ins. and over].	Board Feet.	Number of Merchantable Trees [14 Ins. and over].	Board Feet.	Number of Merchantable Trees [14 Ins. and over].	Board Feet.	
1	744	3.5	441	6.7	1092	16.6	2919	15
2	1425	6.2	990	10.0	1864	20.7	4041	15
3	2109	7.7	1100	12.3	2166	25.6	4926	20
4	2846	9.4	1339	14.9	2624	29.3	5810	21
5	3382	10.3	1470	16.8	3044	40.8	6351	21
6	4035	11.7	1846	18.5	3369	36.0	7531	22
7	4836	14.2	2024	23.8	4279	43.9	8282	21
8	5380	13.5	2043	20.9	4095	39.9	8378	23
9	6783	14.7	2511	23.2	4598	41.4	9541	24
10	7835	15.2	2465	23.8	4769	40.6	9349	27
11	6608	31.0	2646	43.0	8851	61.0	15192	17
12	7072	31.0	5047	46.0	9381	73.0	17409	15

DIAMETER OF LOBLOLLY PINE IN DIFFERENT TYPES.*

Age.	On Old Fields.	In Pure Groups on the Wet Prairie.	In Pure Stands on Fairly Well-drained, Light Soil.	Mixed with Hardwoods.	
				On Well-drained, Fertile Soil.	On Poorly Drained Soil (thicket).
Years.	Inches.	Inches.	Inches.	Inches.	Inches.
5	1.9	1.5	0.2	0.2	0.2
10	4.3	3.7	2.2	2.1	0.9
15	6.1	5.5	4.8	4.0	1.6
20	7.6	6.7	7.6	6.1	2.2
25	8.5	7.7	10.4	7.9	3.0
30	9.3	8.8	12.8	9.5	3.8
35	9.9	9.9	15.0	10.9	4.7
40	16.9	12.4	5.6
50	20.0	15.0	7.8
60	22.3	17.2	9.8
70	24.0	19.3	11.9

* From The Loblolly Pine in Eastern Texas, by R. Zon, Bull. No. 64, U. S. Forest Service, 1905.

HEIGHT OF LOBLOLLY PINE IN DIFFERENT SITUATIONS.*

Age.	On Old Fields.	In Pure Groups on the Wet Prairie.	In Pure Stands on Fairly Well-drained, Light Soil.	Mixed with Hardwoods.	
				On Well-drained, Fertile Soil.	On Poorly Drained Soil (thicket).
Years.	Feet.	Feet.	Feet.	Feet.	Feet.
5	18	11	6	7	5
10	34	29	21	23	13
15	50	45	35	34	21
20	62	57	45	45	28
25	69	67	53	55	34
30	74	73	60	65	39
35	78	79	67	75	44
40	82	84	73	85	49
45	..	89	78	95	53
50	..	95	83	105	57
60	88	..	64
70	91	..	72

* From The Loblolly Pine in Eastern Texas, by R. Zon, Bull. No. 64, U. S. Forest Service 1905.

COMPARATIVE RATE OF GROWTH IN HEIGHT AND DIAMETER
OF CHESTNUT FROM THE SEED AND COPPICE.*

[From the measurement of 1245 trees in Maryland.]

Age, Years.	Height.		Growth each Ten Years.		Annual Growth each Ten Years.	
	Trees from Seed, Feet.	Coppice, Feet.	Trees from Seed, Feet.	Coppice, Feet.	Trees from Seed, Feet.	Coppice Feet.
10	7	23	7	23	0.7	2.3
20	17	42	10	19	1.0	1.9
30	33	57	16	15	1.6	1.5
40	52	69	19	12	1.9	1.2
50	64	77	12	8	1.2	.8
60	73	83	9	6	.9	.6
70	80	87	7	4	.7	.4
80	84	90	4	3	.4	.3
90	88	92	4	2	.4	.2
100	91	93	3	1	.3	.1
110	93	94	2	1	.2	.1
120	95	95	2	1	.2	.1

Age, Years.	Diameter, Breast-high.		Growth each Ten Years.		Annual Growth each Ten Years.	
	Trees from Seed, Inches.	Coppice, Inches.	Trees from Seed, Inches.	Coppice, Inches.	Trees from Seed, Inches.	Coppice, Inches.
10	0.8	3.8	0.8	3.8	0.1	0.4
20	3.4	6.8	2.6	3.0	.3	.3
30	6.0	9.3	2.6	2.5	.3	.3
40	8.7	11.4	2.7	2.1	.3	.2
50	11.2	13.4	2.5	2.0	.3	.2
60	13.4	15.1	2.2	1.7	.2	.2
70	15.4	16.7	2.0	1.6	.2	.2
80	17.2	18.0	1.8	1.3	.2	.1
90	18.8	19.2	1.6	1.2	.2	.1
100	20.1	19.8	1.3	.6	.1	.1
110	21.0	20.4	.9	.6	.1	.1
120	21.6	20.8	.6	.4	.1	.1

* From Chestnut in Southern Maryland, by R. Zon, Bull. No. 53, U. S. Forest Service.

RATE OF GROWTH OF CHESTNUT.

[From the measurement of 68 trees in Connecticut.]

A. DOMINANT TREES IN THE FOREST.

Age. Years.	Diameter on Stump. Inside Bark. Inches.	Diameter Breast-high. Outside Bark. Inches.	Diameter at 10 Ft. above Stump. Inside Bark. Inches.	Diameter at 20 Ft. above Stump. Inside Bark. Inches.	Diameter at 30 Ft. above Stump. Inside Bark. Inches.	Diameter at 35 Ft. above Stump. Inside Bark. Inches.
10	2.1	2.1	1.35	0.3		
20	5.4	5.1	4.3	3.4	0.9	
30	8.7	7.8	6.9	6.1	3.7	2.9
40	11.45	9.7	8.9	8.0	5.8	5.0
50	13.7	11.3	10.6	9.5	7.25	6.5
60	12.5	11.9	10.7	8.55	7.8

B. TREES IN THE OPEN.

10	3.0	3.0	2.2			
20	7.8	7.4	5.9	4.5	2.5	
30	13.2	11.5	9.8	8.0	6.0	
40	18.5	15.3	13.2	11.0	7.9	
50	23.4	18.5	15.9	13.4	11.2	

RATE OF GROWTH OF RED CEDAR.

[Based on the measurement of 23 trees near New Haven, Conn.]

A. TREES IN THE OPEN.

Age. Years.	Diameter, Inside Bark on Stump. Inches.	Diameter, Inside Bark at 6 Ft. above Stump. Inches.	Diameter, Inside Bark at 12 Ft. above Stump. Inches.	Diameter, Inside Bark at 18 Ft. above Stump. Inches.
30	5.5	4.0	2.3	1.6
40	6.8	5.1	3.5	2.6
50	7.8	5.9	4.5	3.6

B. TREES CROWDED, BUT NOT OVERTOPPED.

30	4.8	3.7	2.3	1.3
40	5.9	5.0	3.3	2.1
50	6.8	6.0	4.1	2.6
60	7.4	6.6	4.6	2.8

C. TREES FREE IN YOUTH, BUT LATER ON OVERTOPPED.

40	4.4	3.7	2.7	1.4
50	5.1	4.5	3.4	2.2
60	5.5	4.8	3.7	3.0

FOREST MENSURATION.

RED OAK.

MAXIMUM GROWTH OF TREES IN A SPROUT STAND.

[Based on the measurement of 53 trees near New Haven, Conn.]

Age Years.	Diameter Breast-high, Outside Bark, Inches.	Height, Feet.
20	3.5	36
30	5.4	47
40	7.3	57
50	8.8	65
60	10.4	70
70	11.2	..

PITCH PINE IN PIKE COUNTY, PENNSYLVANIA.

RATE OF GROWTH IN DIAMETER.

Age, Years.	Diameter Breast-high, Inches.	Diameter Inside the Bark.					
		1' High, Inches.	11' High, Inches.	21' High, Inches.	31' High, Inches.	41' High, Inches.	51' High, Inches.
10	2.7	2.1					
20	4.6	4.0	0.6				
30	6.4	5.8		0.8			
40	8.0	7.4	4.6	2.7	0.2		
50	9.4	8.8	6.2	4.3	2.0		
60	10.5	9.9	7.4	5.6	3.6	0.7	
70	11.2	10.6	8.4	6.7	4.9	2.5	
80	11.6	11.0	9.1	7.7	6.0	3.7	0.6
90	11.9	11.3	9.6	8.3	6.8	4.8	2.0
100	12.1	11.5	10.0	9.2	7.4	5.7	3.2

RATE OF GROWTH IN VOLUME.

Age, Years.	Fuel-wood.		Lumber.		
	Whole Trees.		One-log Trees, Board Feet.	Two-log Trees, Board Feet.	Three-log Trees, Board Feet.
	Cubic Feet.	Cords.			
40	6.5	0.073			
50	10.6	.119	20.0	29.7	
60	13.4	.161	24.3	36.9	47.2
70	16.3	.182	28.0	42.9	53.8
80	17.7	.198	30.5	47.1	58.4
90	18.8	.210	32.3	50.3	61.9
100	19.6	.219	33.8	52.6	64.4

MISCELLANEOUS TABLES.

There are included under this head tables to which a forester has frequently occasion to refer and which often are not easily accessible.

The forester has constant use for the table of basal areas in determining the cubic contents of logs and trees, and in using accurate methods to determine the cubic contents of stands.

The tables for converting the metric into the English measure will be found useful in comparing the volume and the growth and yield of European trees with our own.

The table of natural tangents is included to assist in using height measures which show angles in degrees.

AREAS OF CIRCLES.

Diameter, Inches.	Area, Square Feet.	Diameter, Inches.	Area, Square Feet.	Diameter, Inches.	Area, Square Feet.	Diameter, Inches.	Area, Square Feet.	Diameter, Inches.	Area, Square Feet.	Diameter, Inches.	Area, Square Feet.
1.0	.006	2.0	.022	3.0	.049	4.0	.087	5.0	.136	6.0	.196
.1	.007	.1	.024	.1	.052	.1	.092	.1	.142	.1	.203
.2	.008	.2	.026	.2	.056	.2	.096	.2	.147	.2	.210
.3	.009	.3	.029	.3	.059	.3	.101	.3	.153	.3	.216
.4	.011	.4	.031	.4	.063	.4	.106	.4	.159	.4	.223
1.5	.012	2.5	.034	3.5	.067	4.5	.111	5.5	.165	6.5	.230
.6	.014	.6	.037	.6	.071	.6	.115	.6	.171	.6	.238
.7	.016	.7	.040	.7	.075	.7	.121	.7	.177	.7	.245
.8	.018	.8	.043	.8	.079	.8	.126	.8	.184	.8	.252
.9	.020	.9	.046	.9	.083	.9	.131	.9	.190	.9	.260
7.0	.267	8.0	.349	9.0	.442	10.0	.545	11.0	.660	12.0	.785
.1	.275	.1	.358	.1	.452	.1	.556	.1	.672	.1	.799
.2	.283	.2	.367	.2	.462	.2	.568	.2	.684	.2	.812
.3	.291	.3	.376	.3	.472	.3	.579	.3	.697	.3	.825
.4	.299	.4	.385	.4	.482	.4	.590	.4	.709	.4	.839
7.5	.307	8.5	.394	9.5	.492	10.5	.601	11.5	.721	12.5	.852
.6	.315	.6	.403	.6	.503	.6	.613	.6	.734	.6	.866
.7	.323	.7	.413	.7	.513	.7	.625	.7	.747	.7	.880
.8	.332	.8	.422	.8	.524	.8	.636	.8	.760	.8	.894
.9	.340	.9	.432	.9	.535	.9	.648	.9	.772	.9	.908
13.0	.922	14.0	1.069	15.0	1.227	16.0	1.396	17.0	1.576	18.0	1.767
.1	.936	.1	1.084	.1	1.244	.1	1.414	.1	1.595	.1	1.787
.2	.950	.2	1.100	.2	1.260	.2	1.431	.2	1.614	.2	1.807
.3	.965	.3	1.115	.3	1.277	.3	1.449	.3	1.632	.3	1.827
.4	.979	.4	1.131	.4	1.294	.4	1.467	.4	1.651	.4	1.847
13.5	.994	14.5	1.147	15.5	1.310	16.5	1.485	17.5	1.670	18.5	1.867
.6	1.009	.6	1.163	.6	1.327	.6	1.503	.6	1.689	.6	1.887
.7	1.024	.7	1.179	.7	1.344	.7	1.521	.7	1.709	.7	1.907
.8	1.039	.8	1.195	.8	1.362	.8	1.539	.8	1.728	.8	1.928
.9	1.054	.9	1.211	.9	1.379	.9	1.558	.9	1.748	.9	1.948

AREAS OF CIRCLES—Continued.

Diameter Inches.	Area, Square Feet.	Diameter, Inches.	Area, Square Feet.	Diameter, Inches.	Area, Square Feet.	Diameter, Inches.	Area, Square Feet.	Diameter, Inches.	Area, Square Feet.	Diameter, Inches.	Area, Square Feet.
19.0	1.969	20.0	2.182	21.0	2.405	22.0	2.640	23.0	2.885	24.0	3.142
.1	1.990	.1	2.204	.1	2.428	.1	2.664	.1	2.910	.1	3.168
.2	2.011	.2	2.226	.2	2.451	.2	2.688	.2	2.936	.2	3.194
.3	2.032	.3	2.248	.3	2.475	.3	2.712	.3	2.961	.3	3.221
.4	2.053	.4	2.270	.4	2.498	.4	2.737	.4	2.986	.4	3.247
19.5	2.074	20.5	2.292	21.5	2.521	22.5	2.761	23.5	3.012	24.5	3.275
.6	2.095	.6	2.315	.6	2.545	.6	2.786	.6	3.038	.6	3.301
.7	2.117	.7	2.337	.7	2.568	.7	2.810	.7	3.064	.7	3.328
.8	2.138	.8	2.360	.8	2.592	.8	2.835	.8	3.089	.8	3.355
.9	2.160	.9	2.383	.9	2.616	.9	2.860	.9	3.115	.9	3.382
25.0	3.409	26.0	3.687	27.0	3.976	28.0	4.276	29.0	4.587		
.1	3.436	.1	3.715	.1	4.006	.1	4.307	.1	4.619		
.2	3.464	.2	3.744	.2	4.035	.2	4.337	.2	4.650		
.3	3.491	.3	3.773	.3	4.065	.3	4.368	.3	4.682		
.4	3.519	.4	3.801	.4	4.095	.4	4.399	.4	4.714		
25.5	3.547	26.5	3.830	27.5	4.125	28.5	4.430	29.5	4.746		
.6	3.574	.6	3.860	.6	4.155	.6	4.461	.6	4.779		
.7	3.602	.7	3.888	.7	4.185	.7	4.493	.7	4.811		
.8	3.631	.8	3.917	.8	4.215	.8	4.524	.8	4.844		
.9	3.659	.9	3.947	.9	4.246	.9	4.555	.9	4.876		
30.0	4.909	31.0	5.241	32.0	5.585	33.0	5.940	34.0	6.305		
35.0	6.681	36.0	7.069	37.0	7.467	38.0	7.876	39.0	8.296		
40.0	8.727	41.0	9.168	42.0	9.621	43.0	10.085	44.0	10.559		
45.0	11.045	46.0	11.541	47.0	12.048	48.0	12.566	49.0	13.095		
50.0	13.635	51.0	14.186	52.0	14.748	53.0	15.321	54.0	15.904		
55.0	16.499	56.0	17.104	57.0	17.721	58.0	18.348	59.0	18.986		
60.0	19.635										

AREAS OF CIRCLES.*

[Metric System.]

Diameter, Centimeters.	Area, Square Meters.	Diameter, Centimeters.	Area, Square Meters.	Diameter, Centimeters.	Area, Square Meters.	Diameter, Centimeters.	Area, Square Meters.
100	0.78540	135	1.43139	170	2.26980	205	3.30064
101	0.80118	136	1.45267	171	2.29658	206	3.33292
102	0.81713	137	1.47411	172	2.32352	207	3.36535
103	0.83323	138	1.49571	173	2.35062	208	3.39795
104	0.84949	139	1.51747	174	2.37787	209	3.43070
105	0.86590	140	1.53938	175	2.40528	210	3.46361
106	0.88247	141	1.56145	176	2.43285	211	3.49667
107	0.89920	142	1.58368	177	2.46057	212	3.52989
108	0.91609	143	1.60606	178	2.48846	213	3.56327
109	0.93313	144	1.62860	179	2.51649	214	3.59681
110	0.95033	145	1.65130	180	2.54469	215	3.63050
111	0.96769	146	1.67415	181	2.57304	216	3.66435
112	0.98520	147	1.69717	182	2.60155	217	3.69836
113	1.00287	148	1.72034	183	2.63022	218	3.73253
114	1.02070	149	1.74366	184	2.65904	219	3.76685
115	1.03869	150	1.76715	185	2.68803	220	3.80133
116	1.05683	151	1.79079	186	2.71716	221	3.83596
117	1.07513	152	1.81458	187	2.74646	222	3.87076
118	1.09359	153	1.83854	188	2.77591	223	3.90571
119	1.11220	154	1.86265	189	2.80552	224	3.94081
120	1.13097	155	1.88692	190	2.83529	225	3.97608
121	1.14990	156	1.91134	191	2.86521	226	4.01150
122	1.16899	157	1.93593	192	2.89529	227	4.04708
123	1.18823	158	1.96067	193	2.92553	228	4.08281
124	1.20763	159	1.98557	194	2.95592	229	4.11871
125	1.22718	160	2.01062	195	2.98648	230	4.15476
126	1.24690	161	2.03583	196	3.01719	231	4.19096
127	1.26677	162	2.06120	197	3.04805	232	4.22733
128	1.28680	163	2.08672	198	3.07907	233	4.26385
129	1.30698	164	2.11241	199	3.11026	234	4.30053
130	1.32732	165	2.13825	200	3.14159	235	4.33736
131	1.34782	166	2.16424	201	3.17309	236	4.37435
132	1.36848	167	2.19040	202	3.20474	237	4.41150
133	1.38929	168	2.21671	203	3.23655	238	4.44881
134	1.41026	169	2.24318	204	3.26851	239	4.48627

* The areas of circles having diameters less than 100 centimeters may be obtained from this table by moving the decimal point.

AREAS OF CIRCLES—(Continued).

Diameter, Centimeters.	Area, Square Meters.	Diameter, Centimeters.	Area, Square Meters.	Diameter, Centimeters.	Area, Square Meters.	Diameter, Centimeters.	Area, Square Meters.
240	4.52389	275	5.93957	310	7.54768	345	9.34820
241	4.56167	276	5.98285	311	7.59645	346	9.40247
242	4.59961	277	6.02628	312	7.64538	347	9.45690
243	4.63770	278	6.06987	313	7.69447	348	9.51149
244	4.67595	279	6.11362	314	7.74371	349	9.56623
245	4.71435	280	6.15752	315	7.79311	350	9.62113
246	4.75292	281	6.20158	316	7.84267	351	9.67618
247	4.79164	282	6.24580	317	7.89239	352	9.73140
248	4.83051	283	6.29018	318	7.94226	353	9.78677
249	4.86955	284	6.33471	319	7.99229	354	9.84230
250	4.90874	285	6.37940	320	8.04248	355	9.89798
251	4.94809	286	6.42424	321	8.09282	356	9.95382
252	4.98759	287	6.46925	322	8.14332	357	10.0098
253	5.02726	288	6.51441	323	8.19398	358	10.0660
254	5.06707	289	6.55972	324	8.24480	359	10.1223
255	5.10705	290	6.60520	325	8.29577	360	10.1788
256	5.14719	291	6.65083	326	8.34690	361	10.2354
257	5.18748	292	6.69662	327	8.39818	362	10.2922
258	5.22792	293	6.74256	328	8.44963	363	10.3491
259	5.26853	294	6.78867	329	8.50123	364	10.4062
260	5.30929	295	6.83493	330	8.55299	365	10.4635
261	5.35021	296	6.88134	331	8.60490	366	10.5209
262	5.39129	297	6.92792	332	8.65697	367	10.5784
263	5.43252	298	6.97465	333	8.70920	368	10.6362
264	5.47391	299	7.02154	334	8.76159	369	10.6941
265	5.51546	300	7.06858	335	8.81413	370	10.7521
266	5.55716	301	7.11579	336	8.86683	371	10.8103
267	5.59902	302	7.16315	337	8.91969	372	10.8687
268	5.64104	303	7.21066	338	8.97270	373	10.9272
269	5.68322	304	7.25834	339	9.02587	374	10.9858
270	5.72555	305	7.30617	340	9.07920	375	11.0447
271	5.76804	306	7.35415	341	9.13269	376	11.1036
272	5.81069	307	7.40230	342	9.18633	377	11.1628
273	5.85349	308	7.45060	343	9.24013	378	11.2221
274	5.89646	309	7.49906	344	9.29409	379	11.2815

AREAS OF CIRCLES—(Continued).

Diameter. Centimeters.	Area, Square Meters.	Diameter. Centimeters.	Area, Square Meters.	Diameter. Centimeters.	Area, Square Meters.	Diameter. Centimeters.	Area, Square Meters.
380	11.3411	410	13.2025	440	15.2053	470	17.3494
381	11.4009	411	13.2670	441	15.2745	471	17.4234
382	11.4608	412	13.3317	442	15.3439	472	17.4974
383	11.5209	413	13.3965	443	15.4134	473	17.5716
384	11.5812	414	13.4614	444	15.4830	474	17.6460
385	11.6416	415	13.5265	445	15.5528	475	17.7205
386	11.7021	416	13.5918	446	15.6228	476	17.7952
387	11.7628	417	13.6572	447	15.6930	477	17.8701
388	11.8237	418	13.7228	448	15.7633	478	17.9451
389	11.8847	419	13.7885	449	15.8337	479	18.0203
390	11.9459	420	13.8544	450	15.9043	480	18.0956
391	12.0072	421	13.9205	451	15.9751	481	18.1711
392	12.0687	422	13.9867	452	16.0460	482	18.2467
393	12.1304	423	14.0531	453	16.1171	483	18.3225
394	12.1922	424	14.1196	454	16.1883	484	18.3984
395	12.2542	425	14.1863	455	16.2597	485	18.4745
396	12.3163	426	14.2531	456	16.3313	486	18.5508
397	12.3786	427	14.3201	457	16.4030	487	18.6272
398	12.4410	428	14.3872	458	16.4748	488	18.7038
399	12.5036	429	14.4545	459	16.5468	489	18.7805
400	12.5664	430	14.5220	460	16.6190	490	18.8574
401	12.6293	431	14.5896	461	16.6914	491	18.9345
402	12.6923	432	14.6574	462	16.7639	492	19.0117
403	12.7556	433	14.7254	463	16.8365	493	19.0890
404	12.8190	434	14.7934	464	16.9093	494	19.1665
405	12.8825	435	14.8617	465	16.9823	495	19.2442
406	12.9462	436	14.9301	466	17.0554	496	19.3221
407	13.0100	437	14.9987	467	17.1287	497	19.4000
408	13.0741	438	15.0674	468	17.2021	498	19.4782
409	13.1382	439	15.1363	469	17.2757	499	19.5565

TABLES FOR THE CONVERSION OF THE METRIC TO THE ENGLISH SYSTEM.

<p>Hectares to Acres.</p> <p>1 = 2.47109 2 = 4.94213 3 = 7.41327 4 = 9.88436 5 = 12.35545 6 = 14.82654 7 = 17.29763 8 = 19.76872 9 = 22.23981</p> <p>Kilos to Pounds.</p> <p>1 = 2.20462 2 = 4.40924 3 = 6.61386 4 = 8.81848 5 = 11.02310 6 = 13.22772 7 = 15.43234 8 = 17.63696 9 = 19.84158</p> <p>Centimeters to Inches.</p> <p>1 = .39370423 2 = .78740846 3 = 1.18111269 4 = 1.57481692 5 = 1.96852115 6 = 2.36222538 7 = 2.75592961 8 = 3.14963384 9 = 3.54333807</p> <p>Meters to Feet.</p> <p>1 = 3.280869 2 = 6.561738 3 = 9.842607 4 = 13.123476 5 = 16.404345 6 = 19.685214 7 = 22.966083 8 = 26.246952 9 = 29.527821</p>	<p>Acres to Hectares.</p> <p>1 = .40467 2 = .80934 3 = 1.21401 4 = 1.61868 5 = 2.02335 6 = 2.42802 7 = 2.83269 8 = 3.23736 9 = 3.64203</p> <p>Cubic Meters per Hectare to Cubic Feet per Acre.</p> <p>1 = 14.291 2 = 28.582 3 = 42.873 4 = 57.164 5 = 71.455 6 = 85.746 7 = 100.037 8 = 114.328 9 = 128.619</p> <p>Kilometers to Miles.</p> <p>1 = .62137676 2 = 1.24275352 3 = 1.86413028 4 = 2.48550704 5 = 3.10688380 6 = 3.72826056 7 = 4.34963732 8 = 4.97101408 9 = 5.59239084</p> <p>Cubic Meters to Cubic Feet.</p> <p>1 = 35.315617 2 = 70.631234 3 = 105.946851 4 = 141.262468 5 = 176.578085 6 = 211.893702 7 = 247.209319 8 = 282.524936 9 = 317.840553</p>
--	---

TABLE OF NATURAL TANGENTS
EXPRESSED AS PERCENTS.

Minutes.	Degrees.							
	0	1	2	3	4	5	6	7
	Percents.							
0	...	1.75	3.49	5.24	6.99	8.75	10.51	12.28
5	.15	1.89	3.64	5.39	7.14	8.90	10.66	12.43
10	.29	2.04	3.78	5.53	7.29	9.04	10.80	12.57
15	.44	2.18	3.93	5.68	7.43	9.19	10.95	12.72
20	.58	2.33	4.07	5.82	7.58	9.34	11.10	12.87
25	.73	2.47	4.22	5.97	7.72	9.48	11.25	13.02
30	.87	2.62	4.37	6.12	7.87	9.63	11.39	13.17
35	1.02	2.76	4.51	6.26	8.02	9.78	11.54	13.31
40	1.16	2.91	4.66	6.41	8.16	9.92	11.69	13.46
45	1.31	3.06	4.80	6.55	8.31	10.07	11.84	13.61
50	1.46	3.20	4.95	6.70	8.46	10.22	11.98	13.76
55	1.60	3.35	5.09	6.85	8.60	10.36	12.13	13.91

Minutes.	Degrees.							
	8	9	10	11	12	13	14	15
	Percents.							
0	14.05	15.84	17.63	19.44	21.26	23.09	24.93	26.79
5	14.20	15.99	17.78	19.59	21.41	23.24	25.09	26.95
10	14.35	16.14	17.93	19.74	21.56	23.39	25.24	27.11
15	14.50	16.29	18.08	19.89	21.71	23.55	25.40	27.26
20	14.65	16.44	18.23	20.04	21.86	23.70	25.55	27.42
25	14.80	16.58	18.38	20.19	22.02	23.85	25.71	27.58
30	14.95	16.73	18.53	20.35	22.17	24.01	25.86	27.73
35	15.09	16.88	18.68	20.50	22.32	24.16	26.02	27.89
40	15.24	17.03	18.83	20.65	22.47	24.32	26.17	28.05
45	15.39	17.18	18.99	20.80	22.63	24.47	26.33	28.20
50	15.54	17.33	19.14	20.95	22.78	24.62	26.48	28.36
55	15.69	17.48	19.29	21.10	22.93	24.78	26.64	28.52

Minutes.	Degrees.							
	16	17	18	19	20	21	22	23
	Percents.							
0	28.67	30.57	32.49	34.43	36.40	38.39	40.40	42.45
5	28.83	30.73	32.65	34.60	36.56	38.55	40.57	42.62
10	28.99	30.89	32.81	34.76	36.73	38.72	40.74	42.79
15	29.15	31.05	32.98	34.92	36.89	38.89	40.91	42.96
20	29.31	31.21	33.14	35.08	37.06	39.06	41.08	43.14
25	29.46	31.37	33.30	35.25	37.22	39.22	41.25	43.31
30	29.62	31.53	33.46	35.41	37.39	39.39	41.42	43.48
35	29.78	31.69	33.62	35.58	37.55	39.56	41.59	43.65
40	29.94	31.85	33.78	35.74	37.72	39.73	41.76	43.83
45	30.10	32.01	33.95	35.90	37.89	39.90	41.93	44.00
50	30.26	32.17	34.11	36.07	38.05	40.06	42.10	44.17
55	30.41	32.33	34.27	36.23	38.22	40.23	42.28	44.35

TABLE OF NATURAL TANGENTS—(Continued).

Minutes.	Degrees.						
	24	25	26	27	28	29	30
	Percents.						
0	44.52	46.63	48.77	50.95	53.17	55.43	57.74
5	44.70	46.81	48.95	51.14	53.36	55.62	57.93
10	44.87	46.99	49.13	51.32	53.54	55.81	58.12
15	45.05	47.16	49.31	51.50	53.73	56.00	58.32
20	45.22	47.34	49.50	51.69	53.92	56.19	58.51
25	45.40	47.52	49.68	51.87	54.11	56.39	58.71
30	45.57	47.70	49.86	52.06	54.30	56.58	58.90
35	45.75	47.88	50.04	52.24	54.48	56.77	59.10
40	45.92	48.06	50.22	52.43	54.67	56.96	59.30
45	46.10	48.23	50.40	52.61	54.86	57.15	59.49
50	46.28	48.41	50.59	52.80	55.05	57.35	59.69
55	46.45	48.59	50.77	52.98	55.24	57.54	59.89

Minutes.	Degrees.						
	31	32	33	34	35	36	37
	Percents.						
0	60.09	62.49	64.94	67.45	70.02	72.65	75.36
5	60.28	62.69	65.15	67.66	70.24	72.88	75.58
10	60.48	62.89	65.36	67.87	70.46	73.10	75.81
15	60.68	63.10	65.56	68.09	70.67	73.32	76.04
20	60.88	63.30	65.77	68.30	70.89	73.55	76.27
25	61.08	63.50	65.98	68.51	71.11	73.77	76.50
30	61.28	63.71	66.19	68.73	71.33	74.00	76.73
35	61.48	63.91	66.40	68.94	71.55	74.22	76.96
40	61.68	64.12	66.61	69.16	71.77	74.45	77.20
45	61.88	64.32	66.82	69.37	71.99	74.67	77.43
50	62.08	64.53	67.03	69.59	72.21	74.90	77.66
55	62.28	64.73	67.24	69.80	72.43	75.13	77.89

Minutes.	Degrees.						
	38	39	40	41	42	43	44
	Percents.						
0	78.13	80.98	83.91	86.93	90.04	93.25	96.57
5	78.36	81.22	84.16	87.18	90.30	93.52	96.85
10	78.60	81.46	84.41	87.44	90.57	93.80	97.13
15	78.83	81.70	84.66	87.70	90.83	94.07	97.42
20	79.07	81.95	84.91	87.96	91.10	94.35	97.70
25	79.31	82.19	85.16	88.21	91.37	94.62	97.98
30	79.54	82.43	85.41	88.47	91.63	94.90	98.27
35	79.78	82.68	85.66	88.73	91.90	95.17	98.56
40	80.02	82.92	85.91	88.99	92.17	95.45	98.84
45	80.26	83.17	86.17	89.25	92.44	95.73	99.13
50	80.50	83.42	86.42	89.52	92.71	96.01	99.42
55	80.74	83.66	86.67	89.78	92.98	96.29	99.71

INDEX.

	PAGE
Abney Hand Level.....	122, 145, 146
Accretion (see Growth).....	254
Accuracy in Measurements.....	79
Adirondack Standard.....	9, 54, 56
Age, below Stump.....	244
Classes.....	178
Economic.....	251
Estimating, Methods of.....	246
External Signs of.....	247
Influence on Form Factor.....	178
Age of Stands.....	248
Determined by Arithmetic Method.....	250
“ “ Basal Area Method.....	252
“ “ Smalian's Method.....	251
Age of Suppressed Trees.....	249, 252
Tropical Trees.....	247
Age of Trees, Determination of.....	244
Ake Log Rule.....	24, 52
Alabama, Log Rules in.....	50
Allowance Plank.....	32
Analysis, Tree.....	256, 264
Partial Tree or Section.....	257
Section.....	257
Stem (see Tree Analysis).	
Stump.....	257
Angle Mirror.....	212
Adjustable.....	213
Annual Rings.....	244
Counting of.....	245
Measurement of.....	258, 260, 261, 262, 277
Arbitrary Group Method.....	229

	PAGES
Area Growth.	254, 282, 303
Areas of Circles.	90, 430
Cross-sections.	90, 258
Arithmetic Average Tree.	225
Arkansas, Log Rules in.	21, 38, 50, 359
Average Age, Determination of.	248
Average Diameter.	225, 259, 271
Average Radius.	258
Average Tree.	158, 160, 193, 225, 241, 249, 270
Ballon Log Rule.	24, 51
Balsam Fir.	35, 276
Bangor Log Rule.	24, 35
Bark, Measurement of.	61, 78, 153
Bark Blazer.	216
Basal Area.	90
Table of.	430, 432
Multiple Table of.	376
Baughman's Log Rules.	24, 48
Baur, Franz, Investigations by.	8, 103, 178, 181, 319, 325, 415
Bavarian Tables.	181
Baxter Log Rule.	24, 48
Beech.	169, 188
Beech, Form Factors of.	413, 415
Yield Tables for.	418
Behm's Tables.	180
Big Sandy Cube Rule.	57
Birch.	169, 268
Block's Method.	240
Bloedgett Log Rule.	55, 65
Board Foot.	9, 11
Board Measure.	9, 11
Applied to Round Logs.	12
Ratio to Cord Measure.	110
" " Cubic Measure.	110
" " Standard Measure.	55, 56, 57, 59
Value of.	14
Bose's Height Measure.	148
Boynton Log Rule.	24, 51
Branches, Measurement of.	115
Brandis Height Measure.	122, 141
Breast-height Diameter.	112
Breast-height Form Factor.	174
Breyman's Formula.	97
British Columbia Log Rule.	21, 24, 46

	PAGES
Brunton's Compass.....	214
Burt's Quarter Girth Method.....	96
California, Log Rules in.....	45, 360
Calipers.....	65, 81, 102
European.....	82
For Measuring Growth.....	260
Use of.....	77, 78, 207
Canadian Log Rules.....	21, 24, 47
Canadian Standard Rules.....	59
Carey Log Rule.....	24, 51, 61
Center-rot.....	66
Champlain Log Rule.....	24, 27, 30
Chapin Log Rule.....	24, 50
Chestnut.....	162, 173, 275, 312, 407, 426, 427
Growth of.....	297, 426, 427
Volume Table for.....	407
Christen Height Measure.....	122, 131
Circle Method of Estimating.....	193
Circles, Areas of.....	90, 376, 430
Circumference, Measurement of.....	77, 90
Clark's Log Rule.....	20, 35
Clear Length.....	116
Clearings, Growth on.....	269
Climate, Influence on Form of Trees.....	178
Combined Doyle and Scribner Log Rule.....	50
Cone.....	85, 87, 92, 93, 94, 95, 114, 156, 183
Connecticut River Log Rule.....	38
Constantine Log Rule.....	24, 26, 28, 47
Conversion of Volume Tables, Cubic to Board Measure.....	168
Converting Tables, Metric to English Measure.....	435
Cook Log Rule.....	49
Cord Foot.....	101
Cord Measure.....	9, 76, 101
Ratio to Board Measure.....	109
" " Cubic Measure.....	103
" " Standard Measure.....	109
Cord-wood, Estimating.....	215, 217, 223, 224, 243
Measurement of.....	75, 101, 102
Seasoning of.....	105
Stacking of.....	105
Table for Measuring.....	400
Volume Tables for.....	165, 173
Yield Tables for.....	343
Crook in Logs.....	20, 35, 73

	PAGES
Crooked River Log Rule.	49
Cross-sections, Age at.	244
Area of.	90
Diameter of.	259
Growth of.	258, 261
Cross Staff-head.	211
Crown Description.	119
Crown Measurement.	116, 118
Cruising, Timber.	191
Cube Rule.	57
Cubic Contents of Logs.	76, 85
Cubic Measure.	9, 76
Use in America.	76
Contents of Logs in.	76, 77
" " Standing Trees in.	155
Ratio to Board Measure.	110
" " a Cord Measure.	103
Cull.	75
Cull Tables.	71
Culling Logs, Methods of.	66
Cumberland River Log Rule.	24, 26, 49
Current Annual Growth.	254
Curve Drawing, 43, 162, 163, 164, 167, 180, 220, 224, 232, 266, 273, 274, 287, 292, 294, 325, 326, 331, 343, 349	
Cylinder.	86
Cylindrical Foot.	102
Cypress.	65
Damage to Forests, Estimate of.	5
Daniels' Log Rules.	20, 24, 27, 32
Death of Young Trees by Lumbering.	336
Death of Young Trees by Shading.	335
Decimal Log Rule.	42
Defects in Logs.	14, 49, 65, 69, 75
Defects in Trees.	207
Dendrometers.	138, 150
Density, Effect on Form.	165, 177
" " Growth.	268, 284
Denzin's Method.	155
Derby Log Rule.	24, 51
Description, Condition of Tree.	119
Crown.	119
Forest.	206, 324, 337, 342, 345, 348
Stem.	119
Tree.	118, 263

	PAGES
Description Plots.....	348
Diagrams Used in Log Rules.....	12, 41, 42, 45, 48
Diagrams of Trees.....	118, 119
Diameter Groups.....	229, 236, 237, 239, 240
Diameter Growth.....	254
Computation of.....	266
For Short Periods.....	277
In Even-aged Stands.....	268, 272, 273, 274
In Uneven-aged Stands.....	275, 276, 278
Investigations of.....	265
Maximum.....	272
Measurement of.....	258, 261, 262
Minimum.....	273
Of Trees of Different Diameters.....	278
Problems of.....	268
Purpose of Studying.....	265
Diameter, Influence on Form Factors.....	179
Diameter Limit.....	334, 337
Diameter Measurements.....	61, 62, 77, 111, 112, 258
Diameter Tape.....	80
Dimick's Standard Rule.....	54
Discounting for Defects in Logs.....	65
Dominant Trees, Growth of.....	271
Doyle Log Rule.....	21, 23, 24, 35, 38, 65, 153, 154
Draudt Method.....	233
Drew Log Rule.....	21, 24, 35, 46
Dusenberry Log Rule.....	24, 48
Dyewood.....	17
Economic Age.....	252
Edging, Waste by.....	29, 32, 38, 39
Ellipse, Area of.....	91
Empirical Yield Tables.....	341, 343
Equivalents, Board Feet in a Cord.....	110
" " " Cubic Foot.....	110
" " " Standard.....	54, 55, 56, 57, 58
Cubic " " Cord.....	103
Standards in a Cord.....	110
Erickson's Method of Estimating.....	198
Estimating Diameters.....	152
Estimating Heights.....	120
Estimating Timber.....	152, 191
By the Eye.....	152, 191
By Inspecting Each Tree.....	194
By Volume Tables.....	219

	PAGES
Estimating Timber, Erickson's Method of.....	198
In 40-rod Strips.	198
In Small Squares.	197
Method Used in Michigan for.....	196
Stand Tables Used in.....	200
Strip Surveys Used in.....	205
European Methods of Scaling Logs.....	93
European Volume Tables.....	166
European Yield Tables.....	317
Evansville Log Rule.....	49
Even-aged Stands, Age of.....	249
Growth in Diameter.....	268, 272, 273, 274
" " Height.....	287
Sample Plots in.....	345
Yield Tables for.....	315
Excelsior-wood.....	9
Exponent of Form.....	183
Extract Wood.....	109
Fabian Log Rule.....	43
Faustmann Height Measure.....	122, 123
Favorite Rule.....	24, 48
Felled Trees, Contents of.....	111
Measurement of.....	111, 224
Field Records.....	63, 119, 208, 219, 221, 222, 223, 224, 264
Fifth Girth Method.....	22, 95
Financial Maturity.....	310
Financial Returns of Forestry.....	2
Finch and Apgar Log Rule.....	24, 52
Fir.....	180, 181
Fire, Growth after.....	269
Fire-wood, Scaling of.....	101
Five-line Rule.....	65
Flats, Scaling of.....	75
Florida, Log Rules in.....	21, 38, 360
Forest Description.....	206, 265
Forest Form Factor.....	241, 321
Forest Management.....	314, 322, 335
Forest Maps.....	199, 206
Forest Mensuration, Definition of.....	1
Graphic Methods in.....	349
Importance of.....	2
Literature of.....	7, 368
Relation to Forest Management.....	1
Relation to Silviculture.....	1

	PAGES
Forest Regions.	318
Forest Types.	192, 343
Form Exponents.	182, 186
Form Factors.	155, 168, 174
Absolute.	174, 182, 186, 187, 242
Breast-height.	174
Construction of Tables of.	179
Definition of.	174
False.	176
Influences Affecting Value of.	177
Local or General.	178
Merchantable.	175
Normal.	174, 182
Obtained from Form Exponent.	186
Relation of Form Quotient to.	188
Stem.	175
Tables of.	410, 411, 412, 413, 414, 415
Timber.	175
Tree.	175
True.	175
Use of.	176
Used in Study of Volume Growth.	300
Variations of.	176
Form Height.	184
Form Quotient.	188
Form of Cord-wood Sticks.	103
Form of Logs.	85
Form of Trees.	155, 174
Formulæ for Cubing Logs.	91, 93, 94, 95, 96, 97
Formulæ for Cubing Square Timber.	99, 100
Formulæ for Geometric Bodies.	87
Forty-five Log Rule.	24, 51
France, Scaling in.	96
Fricke's Height Measure.	148
Friedrich's Dendrometer.	150
General Growth Studies.	265
General Volume Tables.	158
General Yield Tables.	316
Geometric Average Age.	251
Geometric Average Tree.	225
Geometric Height Measures.	122
Georgia, Log Rules in.	51
Germany, Scaling in.	92
Girth Measurements.	77

	PAGES
Glens Falls Standard Rule.....	54
Goulier Height Measure.....	122, 144
Graded Log Rules.....	21
Grading of Lumber.....	1
Graphic Interpolation, Described.....	349
Gridironing Method of Strip Surveys.....	204
Groups, Diameter.....	229, 236, 237, 239, 240
Growth, Defined.....	254
After Lumbering.....	338
Current Annual.....	254
In Area.....	254, 282
In Diameter.....	254
In Height.....	254, 283, 284, 289
In Volume.....	254, 270
In Weight.....	254
Mean Annual.....	255, 276
Mean and Current Annual Compared.....	256
Measurement of Diameter.....	258, 260, 261, 262
Of Stands.....	309
Of a Whole Forest.....	313
Of Stands after Thinning.....	274
Of Stands for Short Periods.....	309
On Clearings.....	327
Percent.....	255, 301, 304, 307
Periodic.....	255
Periodic Annual.....	255
Price.....	254
Quality.....	254
Stimulated.....	274, 280
Total.....	255
Guttenberg Dendrometer.....	150
Hand Level, Abney.....	145, 146
Hanna Log Rule.....	24, 38, 45
Hardwoods, Northern.....	35
Southern.....	169
Volume Table for.....	165
Harmonized Curves.....	164, 167, 354
Hartig's Method.....	240
Havlick's Height Measure.....	148
Heading.....	9, 101
Heart-rot.....	67
Height, Average of Stands.....	287
Index of Site.....	284, 320, 322, 326
Height Growth.....	254, 283

	PAGES
Height Growth, Computation of	283
In Even-aged Stands.	287
Maximum and Average.	288, 289
Purpose of Studying.	283
Of Trees of Different Diameter.	288
Height Measures.	122
Choice of.	149
Height of Trees, Measurement of.	120, 148
Hemlock.	276, 283
Herring Log Rule.	24, 49
Heyer's Height Measure.	148
Hickory.	76
Holland Log Rule.	24
Hoop-poles.	9
Hoppus' Rule.	99
Hossfeldt's Method.	94, 155
Huber's Method of Cubing Logs.	93, 115
Humphrey Log Rule.	24, 48
Hypsometers.	122
Hyslop's Log Rule.	42
Idaho, Log Rules in.	21, 41, 50, 360
Illinois, Log Rules in.	49, 50, 51
Increment (see Growth).	254
Borer.	246, 300, 305
Calipers.	260
India, Scaling in.	99
Indian Literature.	8
Indian Yield Tables.	338
Indiana, Log Rules in.	48, 49, 50
Inscribed Square Rule.	100, 396
Instrument-makers.	129, 131, 136, 144, 148, 150, 151, 212, 214
International Log Rule.	24, 35, 36
Iowa, Log Rules in.	50, 360
Isolation Strips.	344
Jack Pine.	269
Kentucky, Log Rules in.	49, 50
Klaussner Height Measure.	122, 133, 134, 149, 151
Knots, Interference in Measuring Logs.	78
Konig, Studies in Cord-wood.	104
Lagging, Scaling of.	75
Larch.	180

	PAGES
Lath.	16
Legislation regarding Log Rules.	21, 359
Lehigh Log Rule.	49
Length Measurements.	62, 84, 111, 113
Limb-wood, Volume of.	115
Literature on Forest Mensuration.	7, 368
Loblolly Pine.	35, 169, 269, 322, 425
Local Volume Tables.	181
Local Yield Tables.	317
Location of Plots in Estimating.	216
Location of Plots for Yield Tables.	327
Location of Strip Surveys.	203
Lodge-pole Pine.	269
Log Lengths.	112
Log Rules.	12
Comparison of.	24, 26
Graded.	21
History of.	22
Local.	18, 21
Mathematics of.	27, 35
Number of.	14
Principles of Constructing.	12
Statute.	21
Universal.	17, 18, 20
Used in Estimating.	152
Log Scales (see Log Rules).
Log Tables (see Log Rules).
Longleaf Pine.	169
Louisiana, Log Rules in.	21, 38, 50, 361
Maine, Log Rules in.	43, 51, 361
Maine Log Rule.	21, 24, 35, 42, 64
Many-aged Stands.	334
Growth in.	275
Permanent Sample Plots in.	346
Yield Tables for.	316, 334
Maple.	169, 284
Market Boards.	23
Marking Logs.	63
Massachusetts, Log Rules in.	45, 49, 51, 52, 362
Maximum Growth, Studies of.	272
Used in Yield Tables.	329
Mayer's Height Measure.	148
Mean Annual Diameter Growth.	276
Mean Annual Growth.	355

	PAGES
Mean Annual Growth of a Forest.	313
of Stands.	312
Used in Yield Tables.	343
Mean Sample-tree Method.	224
Merchantable Length.	116, 164
Metric System.	9
Converting Factors.	435
Metzger's Method.	242
Michigan, Log Rules in.	48, 49, 50
Methods of Estimating in.	196, 198
Mill-scale.	13, 29, 169
Mine Props.	9, 75
Minnesota, Legislation regarding Log Rules.	21, 41, 362
Mississippi, Log Rules in.	50
Missouri, Log Rules in.	48, 50
Mixed Stands, Yield Tables for.	330, 331
Model Acre.	337
Montana, Log Rules in.	50, 52
Moore and Beeman Log Rule.	38
Müller, Udo, Investigations of.	8, 104, 122, 184
Natural Pruning.	116
Natural Tangents, Table of.	436
Neiloid.	86, 89, 95, 183
New Brunswick Log Rule.	21, 24, 47
New Hampshire Log Rule.	21, 24, 35, 55, 61, 64, 363
New Jersey, Log Rules in.	49, 50
Newton's Formula for Cubing Logs.	95
New York, Log Rules in.	45, 48, 50, 51, 54, 57
Nineteen-inch Standard.	54, 398
Noble and Cooley Log Rule.	49
Normal Crook.	35
Normal Form Factors.	174
Normal Stands.	318, 319, 323, 326
Normal Trees.	160
Normal Yield Tables.	318
Construction of.	325
Contents of.	321
Data for.	322, 323
For Thinned Stands.	328
" Unthinned Stands.	327
" Mixed Forests.	331
In this Country.	326
Uses of.	321
North Carolina, Log Rules in.	48, 49

	PAGES
Northwestern Log Rule.....	24, 50
Nosseck's Method of Form Factors.....	186
Novelty Wood.....	9
Number of Log Rules.....	14
Oak.....	76, 283, 332, 333, 334
Form Factors of.....	411
Ocular Estimating.....	152, 191
Oetzel's Formulæ.....	98
Ohio, Log Rules in.....	48, 49, 50
Omnimeter.....	148
Orange River Log Rule.....	24, 50
Oregon, Legislation regarding Log Rules.....	41, 364
Paraboloid.....	85, 88, 91, 93, 94, 156, 183
Parameters.....	183
Parson's Log Rule.....	24, 26, 51, 61
Partial Tree Analysis.....	257
Partridge Log Rule.....	24, 51
Pecky Cypress.....	65
Peltzmann's Dendrometer.....	150
Pennsylvania, Log Rules in.....	45, 48, 49, 50, 51, 52
Percents of Angles.....	436
Periodic Annual Growth.....	255
Periodic Growth.....	255, 277, 278
Periodic Measurements of Plots.....	322
Permanent Sample Plots.....	344, 345
In Europe.....	344
Philippine Islands.....	9
Philipp's Method of Form Factors.....	185
Piles.....	9, 173
Pinchot, White Pine Study.....	316
Pitch Pine.....	173, 269, 283
Growth of.....	428
Volume Tables for.....	408
Plank Measure.....	11
Plot Surveys.....	202, 209
Calipering on.....	216
Instruments for Laying Out.....	210
Irregular.....	214
Necessary Precision in Laying Off.....	214
Plotting on Cross-section Paper.....	350
Pocket Compass.....	214
Poles.....	9, 173
Growth of.....	208

	PAGES
Poplar.	268
Portland Scale.	49
Possible Merchantable Length.	117
Posts.	75, 173
Prediction of Profits of Forestry.	2
Volume Growth.	299
Yield.	335
Pressler's Increment Borer.	246, 255, 300, 305
Method (Contents Standing Trees).	156
" of Determining Volume Growth.	299
" " Estimating Growth of Standing Trees.	304
" " Form Factors.	186
Telescope.	157
Price Growth.	254
Profits of Forestry, Prediction of.	2
Pruning, Natural.	116
Pulp-wood.	9, 16, 65, 101, 109
Pure Stands.	327, 332
Location of Plots in.	216, 327
Purpose of Yield Tables.	321, 335
Quality Growth.	254
Quality of Site.	284
Quarter Girth Method.	99
Quebec Log Rule.	21, 24, 47
Radius, Average.	258
Railroad Ties.	9, 75, 171, 172, 173
Rectangular Coördinates.	350
Red Birch.	170
Red Cedar.	275
Growth of.	427
Red Fir.	269
Red Maple.	310
Red Oak.	284, 312
Growth of.	428
Volume Table for.	409
Red Pine.	269
Relative Diameter.	305
Reproduction Plots.	346
Right Angles, Obtained by Instruments.	210
" " Tape.	214
Rise or Taper.	64
River Logs.	26, 49
Rock Oak.	312

	PAGES
Root Flare.	115
Roots, Volume of.	115
Ropp Rule.	24, 51
Rough Estimating.	120, 190
Rough Sample Plots.	192
Rough Strips.	193
Roughage.	32
Rudorf's Formula.	97
Rueprecht's Height Measure.	148
Saco River Log Rule.	24, 51
Sal.	340
Sample Areas.	202
Sample Plots.	202, 209
Estimate by.	209, 217
In Empirical Yield Tables.	342
" Yield Tables.	323
Location of.	216
Marking Boundaries of.	215
Permanent.	344
Selection for Yield Tables.	323
Shape and Size.	215
Used in Studying Diameter Growth.	270, 271
" " Making Yield Tables.	323, 324
Sample Trees, Permanent.	344
Sanlavlille's Dendrometer.	151
Sap, Rotten, Discount for.	73
Sap-wood, Measurement of.	111
Saranac River Standard Rule.	59
Scale Paddle.	62
Scale Stick.	58, 60
Scaling.	60
In Europe.	92, 93
Logs, Methods of.	60
Rules, on Forest Reserves.	74
Scantling Measure.	11
Scarf, Errors due to.	113
Schaal's Method of Form Factors.	187
Schenck, Method of Cubing Trees.	153
Schneider's Method of Estimating Growth of Standing Trees.	307
Schuberg, Form Factor Tables.	181
Schwappach Normal Yield Tables.	317, 417, 418, 419, 420
Scotch Pine.	180, 181, 188, 318, 324
Form Factors of.	410, 415
Yield Tables for.	420

	PAGES
Scratchers.	210
Scribner Decimal Rule.	42
Scribner Log Rule.	21, 24, 26, 38, 41, 75
Seamy Logs.	73
Seasoning.	105
Second Growth, Estimate of.	201, 209
Value of.	5
Yield Tables.	342
Section Analysis.	257
Sectional Areas.	90
Selection System.	334
Senkendorf, Cord-wood Studies.	103
Seventeen-inch Rule.	100
Shake, Discount for.	70
In Logs.	67
Shakes, Scaling of.	75
Shingles.	16, 75, 101
Shortleaf Pine.	269
Shrinkage.	14, 35, 105
Simony's Formula.	97
Single Tree Plots.	347
Site, Influence on Form of Trees.	178
Sketching of Trees.	119
Skidways, Scaling of.	64, 75
Slabs, Taken off for Defects.	70, 71
Waste by.	29, 32, 38, 39
Smalian's Formula.	114
Method of Determining the Age of Stands.	251
Cubing Logs.	91, 96
Solid Contents of a Cord.	103
South Dakota, Log Rules in.	50
South, Scaling in.	66
Spaulding Log Rule.	21, 24, 45
Splits, Discounts for.	70
Spool-wood.	9
Sprout Stands.	268, 269
Spruce.	35, 180, 188, 269, 276, 283, 310, 317
Growth of.	282
Volume Table for.	406, 407
Yield Table for.	417, 422, 423, 424
Square Measure of Boards.	11
Square Plots.	193, 200
Square Timber.	9, 75, 76, 99, 394, 396
Square of Three-fourths Log Rule.	23, 24, 49
Square of Two-thirds Log Rule.	24, 48

	PAGES
Stacked Cubic Foot.	102
Staff Compass.	210, 211
Staff-head.	211, 212
Stand Tables in Estimating.	200
Standard Log.	9, 53, 54, 55
Standard Measure.	9, 53, 76
Ratio to Board Measure.	54, 55, 56, 57
" " Cord Measure.	109
Standing Trees, Contents of.	152
Estimate of Contents of.	152, 155, 156
Stands, Accurate Determination of Volume of.	190, 224
Contents of.	190
Increment of.	309
Starke's Dendrometer.	150
Statistical Methods in Forest Mensuration.	349
Statute Log Rules.	21
Stem Analyses (see Tree Analyses).	
Stillwell Log Rule.	24, 51
Stimulated Growth.	274, 280
Stötzer's Height Measure.	148
Strip Surveys.	202
Advantage of.	209
Calipering on.	206
Distribution of.	203
In Yield Tables.	335
Number Used in Estimating.	208
Strips in Estimating.	198, 199, 202, 209
Strzelecki's Method of Form Factors.	185
Study of Growth, Importance of.	2
Stump, Diameter Measurements.	112, 113
Height Measurements.	113, 257
Volume of.	115
Stump Analysis.	257
St. Croix Log Rule.	38
St. Louis Hardwood Log Rule.	49
Superficial Measure.	11
Surface Foot.	101
Surface Waste.	29, 32, 38
Tally Board.	208
Tally Record.	208, 219
Tally Register.	106
Tamarack.	276
Taper.	36, 64
Taper, Influence on Contents of Logs.	15

	PAGES .
Tapes.....	19, 80, 84
Teak.....	340
Tennessee, Log Rules in.....	45, 48, 49, 50
Tennessee River Rule.....	49
Test Trees.....	224, 232, 233, 239
In Yield Tables.....	328
Number of.....	227, 230
Selection of.....	226
Texas, Log Rules in.....	48, 49, 50
Thinnings.....	4
Effect on Growth.....	274, 280
Before Measurement.....	328
Third and Fifth Rule.....	49
Thurber Log Rule.....	38
Tiemann's Height Measure.....	148
Timber Cruising.....	191
Estimating.....	191
Ton, a Unit of Measure.....	10
Top Measurements.....	111
Total Growth.....	255
Total Height of Tree.....	113
Total Length.....	113
Tree Analysis.....	256
Preparation of a Tree for.....	257
Selection of Trees for.....	257
Tree Class.....	118, 160, 163, 164, 177, 223, 275
Tree Description.....	118, 159, 263
Tree Form Factor.....	175
Tree Scribe.....	216
Trigonometric Height Measure.....	122
Tropical Trees, Age of.....	247
Growth of.....	348
Yield Tables for.....	338
Trumbach's Height Measure.....	148
Twenty-four Inch Standard Rule.....	59
Twenty-one Inch Standard Rule.....	59
Twenty-two Inch Standard Rule.....	57
Two-thirds Rule, Square Timber.....	99, 394
Uneven-aged Stands, Age of.....	249
Diameter Growth in.....	275, 276, 278
Units of Measurement.....	8
Universal Log Rule, Construction of.....	18
Need of.....	17
Selection of.....	20

	PAGES
Universal Rule (Daniels')	24, 32, 35
Urich Method	236, 324, 344
Used Length	117
U. S. Forest Service	22, 91, 169, 202, 208, 345
Valuation Area	202
Valuation of Land	2
Valuation of Second Growth	335
Valuation Survey	202
Vannoy Log Rule	38
Vermont, Log Rules in	21, 48, 51, 364
Vermont Log Rule	21, 364
Virginia, Log Rules in	45, 48, 49, 50
Virginia Pine	269
Volume-curve Method	232
Volume Growth	254, 290
Computation of	290
Determined by Form Factor Method	300
" " Graphic Method	293
" " Pressler's Method	299
For Short Periods	298
Of Individual Trees	290
" Standing Trees	304, 307
Prediction of	300
Volume, Index of Site	322
Volume Measurements	111
Volume of Felled Trees	111
Volume of Logs, Cubic	76, 99
Volume of Trees, Variation in	158
Volume of Trees on Valuation Areas	219
Volume Tables	11, 158
Construction of	159
Data for	159
Definition of	158
For Chestnut	407
" Pitch Pine	408
" Red Oak	409
" Spruce	406, 407
" White Pine	403, 405
Graded	169
In Europe	166
" Yield Tables	335
Local or General	158, 162
Trees Grouped by Diameters	159
" " " Diameter and Number of Logs ..	163

	PAGES
Volume Tables, Trees Grouped by Diameter and Merchantable	
Length.....	164
Tree Class.....	164
Height.....	166
Wagon Stock.....	9
Walter's Formula.....	98
Warner Log Rule.....	24, 51
Washington, Log Rules in.....	21, 46, 365
Waste in Sawing Logs.....	12, 13, 38
Weise Height Measure.....	122, 129
Weise Yield Tables.....	318
West Virginia, Log Rules in.....	21, 48, 49, 366
Wheel, Measuring.....	62
Wheeler Rule.....	24
White Cedar.....	269
White Log Rule.....	24, 52
White Pine.....	35, 269, 276, 283, 284, 317, 327, 332, 333, 334
White Pine, Rule for Estimating.....	154
Volume Table for.....	403, 405
Yield Table for.....	421
White Oak.....	169
Wilcox Log Rule.....	24, 51
Wilson Log Rule.....	24, 51
Wimminaur's Dendrometer.....	150
Winder Log Rule.....	48
Winkler Dendrometer.....	138, 150
Winkler Height Measure.....	122, 136, 137
Wisconsin, Log Rules in.....	21, 41, 50, 366
Working Plans.....	310
Xylometer.....	115
Yellow Birch.....	169
Graded Volume Tables for.....	171
Yellow Pine.....	269
Yellow Poplar.....	169
Yield Tables.....	201, 315
Empirical.....	316, 341, 343
For Beech.....	418
" Even-aged Stands.....	316
" Many-aged Stands.....	335, 337, 339
" Mixed Forests.....	330, 331
" Scotch Pine.....	420
" Spruce.....	417, 422, 423, 424

	PAGES
Yield Tables for White Pine.....	421
Future.	315
Local or General.	316
Normal or Index.	316, 317
Present.	315
Younglove Log Rule.....	26, 52
Zihlwald Yield Tables.....	318
Zon, R., Cord-wood Studies	106

UNIVERSITY OF MICHIGAN



3 9015 06857 2919

